

McQuay
Air Conditioning

**OPERATING AND
MAINTENANCE DATA**

BULLETIN NO. IM 307-2
DECEMBER, 1986
FORM NO. 306A160H01-A
REPLACES PE/PH-G2

SINGLE COMPRESSOR CENTRIFUGAL CHILLERS
PEH/PHH 050,063,079,087,100,126

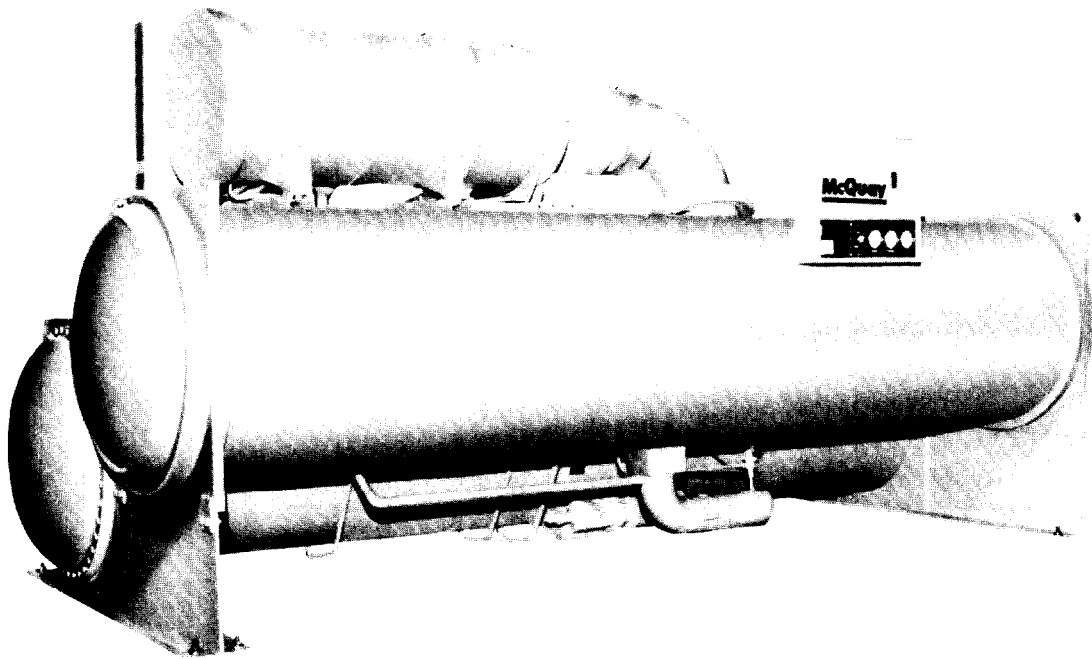

McQuay
Snyder General Corporation

13600 Industrial Park Blvd., P.O. Box 1551, Minneapolis, MN 55440

TABLE OF CONTENTS

INTRODUCTION			
General Description	2	Changing Oil Filter	15
Application	3	Refrigerant Cycle.	15
OPERATION		Electrical System	15
Operator Responsibilities	3	Cleaning and Preserving	15
Nomenclature	3	Seasonal Servicing	15
Operating Sequence	4	Annual Shutdown	15, 16
Control System	4	Annual Start-up	16
Operating Controls	4	Repair of System	16
Control Component Summary	5, 6	Pumping Down	16
Protective Controls	7	Pressure Testing	16
Safety Control Reset	7	Leak Testing	16
Control Center	8—9	Evacuation	16, 17
Temperature Section	9	Refrigeration Charging	17
Relay Section	9	Pressure Relief Valve Replacement	17
Switch Section	9	Equipment Warranty	17
Control Module	9	Refrigerant Charts	17
Capacity Control System	10	ADJUSTMENTS	
Vane Operation	10	Current Limit Calibration	17, 18
Metering Valves	10, 11	Temperature Calibration	18
Oil System	11, 12	Ramp-Up Calibration	18
Hot Gas Bypass System	12	Pulse Rate Calibration	18
Operating the Chiller	12	Current Transformer Signal	18
Preliminary Checks	12	Vane Speed Adjustment	18
Starting the Chiller	13	Load Recycling Thermostat Setting	19
Operating Checks	13	Low Oil Temperature Thermostat	19
Shutdown	14	TROUBLESHOOTING GUIDE 20—22	
MAINTENANCE		McQUAY CENTRIFUGAL OPERATING LOG	23
Routine Maintenance	15	McQUAY SERVICE PROGRAMS 24	
Lubrication	15		

INTRODUCTION

GENERAL DESCRIPTION

The McQuay Model PEH Centrifugal Water Chillers are complete, self-contained, automatically controlled water chilling units. Each unit is completely assembled and factory tested prior to shipment.

In the PEH series, each unit contains one compressor connected to a condenser and evaporator. A sister model called the PHH Heat Recovery Chiller is similar to the PEH models except for the addition of a second split condenser for heat recovery applications.

The PHH models are equipped with a hot gas bypass system for operation at light cooling loads. This hot gas system is standard on PHH units and optional for PEH models.

The standard chillers use refrigerants 12 and 500 to reduce

the size and weight of the package and since they operate at a positive pressure over the entire operation range, no purge system is required.

The controls are completely prewired, adjusted and tested. Only normal field connections such as piping, electrical and pump interlocks, etc. are required thereby simplifying installation and increasing reliability. All necessary safety and operating controls are factory installed in the control panel.

The six basic sizes of units are the PEH050, 063, 079, 087, 100 and 126 and provide a capacity range from 80 tons to 1200 tons. The PEH050 is also applied with modified impellers and are designed as PEH046 or PEH048. In this manual all references to the PEH models will equally apply to PHH models unless specifically referenced otherwise.

APPLICATION

The operation and maintenance procedures presented in this manual apply to the standard model PEH chillers and the model PHH heat recovery chillers. Reference to the installation manual for these units should be made for details pertaining to receiving and handling, installation, piping and wiring, and preparation for initial startup.

All McQuay centrifugal chillers are factory tested prior to shipment and must be initially started by a factory trained McQuay Service technician. Failure to follow this startup procedure may affect the equipment warranty.

The standard warranty on this equipment covers parts which prove defective in material or workmanship. Specific details of this warranty can be found in the warranty statement furnished with the equipment.

In the application of cooling towers with McQuay model PEH centrifugal chillers, the towers are normally selected for maximum condenser inlet water temperature on the order of 85°F.

Lower entering water temperature may be desirable from the standpoint of energy performance but a minimum does exist. For recommendations for optimum entering water temperature and cooling tower fan control, consult McQuay Catalog 950, Applications Section.

The operating and maintenance procedures for the PEH and PHH chillers are identical in most respects; therefore, all references made in this manual for the PEH chillers will equally apply to the PHH models unless specifically noted. For simplicity, only the PEH designation will be used.

OPERATION

OPERATOR RESPONSIBILITIES

It is important that the operator become familiar with the equipment and the system before attempting to operate the chiller.

In addition to reading this manual the operator should study the control diagram furnished with the unit so that he understands the starting, operating and shutdown sequences as well as the safety shutdown modes.

When the McQuay Service technician performs the initial startup of the chiller he will be available to answer any questions and to instruct in proper operating procedures.

It is recommended that the operator maintain an operating log for each individual chiller unit. A suggested log sheet is shown on page 23 of this manual.

In addition, a separate maintenance log should be kept of the periodic maintenance and servicing activities.

This McQuay centrifugal chiller represents a substantial investment and deserves the attention and care normally given to keep this equipment in good working order. If the operator should encounter abnormal or unusual operating conditions, it is recommended that a McQuay Service technician be consulted.

McQuay conducts training for centrifugal operators at its factory Training Center several times a year. These sessions are structured to provide basic classroom instruction and include hands-on operating and troubleshooting exercises. For further information, contact your McQuay representative.

NOMENCLATURE

Each centrifugal chiller is assigned a set of identifying numbers which are used to describe the unit features and to identify each individual unit. These four-number groups are stamped on each unit nameplate.

All inquiries pertaining to operating and servicing of this unit should include all identification numbers.

Each of the individual components also have nameplates to provide certain necessary information to the installer and the operator.

The compressor nameplate identifies the compressor model, style and serial numbers and includes the electrical characteristics of the compressor motor. The CEO50 compressor nameplate also shows the oil pump electrical characteristics.

The condenser and evaporator vessels have nameplates stamped with the maximum working pressure of the vessel. It should be noted that the vessel relief valve maximum settings coincide with the maximum refrigerant side vessel working pressure.

NOMENCLATURE CHANGE: The letter "H" has been added behind the first two digits of the model code to signify a hermetic compressor motor. Models PE and PH are synonymous with PEH and PHH respectively.

OPERATING SEQUENCE

The single compressor PEH/PHH units can be operated as individual units or in multiples as dictated by the system design.

The compressor on-off sequencing is accomplished through response to the Load Recycling Thermostat (LRT) sensing the temperature of the chilled water leaving the chiller.

The chiller will be started by the LRT approximately at the design leaving chilled water temperature and will be stopped at about 3°F below the control temperature.

While in operation, the chiller will be controlled by the Con-

trol Module, loading and unloading the compressor to maintain the desired chilled water temperature.

During all phases of operation, the critical functions of the chiller are under constant surveillance by the safety controls. Abnormal conditions will cause the chiller to be shut down and usually will require some corrective action to prevent recurrence. A set of panel lights on the control panel will indicate the cause of shutdown. For the protection of the equipment, the operator should determine the exact cause of shutdown and correct the situation prior to operating the unit again.

CONTROL SYSTEM

For the proper operation of the centrifugal chiller, a thorough understanding of the control is essential.

The controls are housed for the most part in the Control Center and in the Lube Box, both of which are mounted on the chiller assembly.

A complete summary of the control components presented in Table 1 identifies each control, its location and setting, along with a brief description of its purpose in the control scheme. Most of these controls are standard on all units while a few may be special purpose or optional devices. Using this chart in conjunction with the control diagram shipped with the unit will aid in understanding the various control modes.

For the purpose of describing the controls, they have been divided into two categories **Operating Controls and Protective Controls** and in each group, certain of the important controls will be reviewed in some detail. There are a dozen or so relays in the control center which respond to another controlling device to open or close circuits. These relays can be identified by the operator from the control diagram.

OPERATING CONTROLS

The operating control group consists of devices which serve specific functions in starting, operating and shutting down the centrifugal compressor during normal operating conditions. For this description it is assumed that the system conditions monitored by the safety and protective controls are normal and that those controls are positioned for running.

The ON-OFF switch on the control panel provides a means of manual control to energize or de-energize the operating circuit. When this switch is turned on, its self-contained light will energize and the control circuit is ready for automatic operation of the compressor.

The Load Recycling Thermostat (LRT) sensing leaving chilled water temperature will cycle the compressor on the line when the water temperature reaches the ON setpoint, and will shut the compressor down when the water temperature drops to the OFF setpoint. The setting procedure is detailed in the maintenance section of this manual.

To assure that the compressor will not be started too frequently, the Time Delay Relay (TDR) will prohibit a restart within 20 minutes of the last shutdown. This timing is for the protection of the compressor motor and is not adjustable. It is classified as an operating control because it functions as a part of the starting sequence.

Once the TDR contacts close, the oil pump is started and the Prelube Timer (PLT) is energized to assure oil pumping and bearing lubrication for a fixed time prior to compressor start. At the same time, the oil heaters which have been energized during the compressor-off period are now shut off.

Simultaneous with starting the oil pump, the Oil Cooler Solenoid (OCS) is energized, permitting coolant to flow through the oil cooler to remove the heat generated by the compressor bearings once the compressor starts.

At the end of the prelube period the control circuit is completed up to the Vane Closed switch (VC) which monitors the position of the compressor capacity control vanes. This switch permits compressor starting only when the vanes are in the fully closed position.

To complete the control circuit for compressor starting, the pump interlocks and water flow interlocks for the condenser water and chilled water must be closed. Chilled water pumps are normally operated continuously, whereas condenser pumps may be cycled with the compressor. In this case the Condenser Pump Cycling Relay (CWR) is energized and its starter interlock contacts and condenser water flow switch will complete the control circuit and the compressor will start.

Once the compressor is started, the Control Module functions to load and unload the compressor in response to changes in the leaving chilled water temperature. The Control Module will be discussed in greater detail in a later section.

As the system load reduces and the Control Module unloads the compressor to minimum capacity (about 10% of full load), the compressor will continue to run, reducing the water temperature until the LRT shuts off the machine when the water temperature drops to the OFF setpoint.

The control panel has two lights which indicate the status of control. The COMP RUN light shows that the compressor is running under normal control and the LOAD RECYCLE light indicates the compressor has been taken off line by a normal operating control and is waiting for a restart signal.

FIGURE 2. CONTROL CENTER



TABLE 1. CONTROL COMPONENT SUMMARY — STANDARD APPLICATIONS

CONTROL	SYMBOL	SETTING	RESET (Note 1)	LOCATION	SIGNAL LIGHT	FUNCTION
Alarm Relay	R9 (AL)	None	Auto/Man	Relay Section	None	Actuates circuit for remote alarm (where an AL relay is used, R9 signals opening of a water circuit interlock).
Chiller Pump, Waterflow Interlocks	CHWI	None	Auto/Man	Field Supplied	Ext. Fail	Prevents chiller operation until chilled water pump is energized and flow is established.
Cold Oil Temperature Switch	COT	105°F	Auto/Man	Switch Section	Oil Temp.	Stops compressor if oil temperature entering compressor drops below setting. R114 Templifiers only.
Condenser Pump, Waterflow Interlocks	CWI	None	Auto/Man	Field Supplied	Ext. Fail	Prevents chiller operation until condenser water pump is energized and flow is established.
Guardistor Relay	GR	None	Auto/Man	Relay Section	Motor Temp.	Stops compressor motor when winding temperature exceeds limit.
Hot Gas Override Solenoid	HGO	None	None	Hot Gas Piping	None	Opens hot gas bypass at starting of 2nd compressor oil pump to reduce starting head. Dual compressor units only.
Hot Gas Solenoid	HGS	None	None	Hot Gas Piping	None	Opens hot gas bypass from discharge to evaporator, providing false evaporator load. Helps prevent surge conditions.
Hot Gas Thermostat	HGT	Field Set	None	Condenser Frame	None	Energizes hot gas solenoid on drop in water temperature entering evaporator (senses entering condenser water in Templifier).
High Oil Temperature Switch	HOT	140°F Temp.	Manual (R12)	Switch Section	Oil	Stops compressor if oil temperature entering compressor exceeds setting (reset auto/man with RI 14 Templifiers).
High Pressure Switch	HP	See Function	Manual	Switch Section	Disch. Press	Stops compressor when discharge pressure exceeds setting. Set 10-12 psig above design saturated condensing pressure (not to exceed 90% condenser nameplate maximum working pressure).
High Suction Temp. Switch	HST	150°F	Auto/Man	Temp. Section	Surgegard	Stops compressor when suction temperature exceeds setting prevents compressor surge (CEO50 compressor only).
High Discharge Temp. Switch	HT	225°F	Manual	Switch Section	High Temp.	Stops compressor when discharge gas temperature exceeds setting.
Interval On Timer	IOT	Field Set	None	Lead/Lag Box	None	Actuates circuit for specific time and returns to normal position after time delay.
Low Casting Temp. Thermostat	LCT	110°F	Auto	Temp. Section	Oil Temp.	Assures minimum compressor casting temperature at startup. (CE126 compressor only).
Liquid Injection Solenoid	LIS	None	None	Refrig. Piping	None	Opens liquid injection valve after compressor starts-standard on CE126. (Optional for CE063, 079, 087, 100) (Not used on R114 units)
Load Meter	LM	None	None	Panel	None	Displays percent of full load amps when compressor runs.
Low Oil Temp. Thermostat	LOT	130°F	Auto	Temp. Section	Oil Temp.	Prevents compressor start with cold oil. Set as high as conditions allow. Protects compressor bearings from refrigerant diluted oil.
Low Pressure Switch	LP	See Function	Manual	Switch Section	Low Press.	Stops compressor when suction pressure drops below setting. Set 5 psig below shop order suction pressure.
Pump Down Control Switch	LPC	2-5 psig above LP	Auto	Side of Panel	None	Stops compressor when suction pressure setting is reached-part of one-time pump down control feature-SE units only.
Low Pressure Override Switch	LPO	2 psig above LP	Auto	Switch Section	None	Overrides control module, unloads compressor when suction pressure approaches setting of LP cutout-prevents nuisance trip.
Load Recycle Thermostat	LRT	Field Set	None	Temp. Section	Load Recycle	Starts/stops compressor in response to load changes-stops compressor 3°F below control point. (See PF manual for LRT2 setting.)
Liquid Line Solenoid Valve	LS	None	None	Field Supplied	None	Opens on call for cooling or heating. Closes when system thermostat or controller is satisfied.
Oil Pump Contactor	IM	None	None	Relay Section	None	Starts oil pump when energized.
Motor Control Relay	MCR	None	None	Starter	Comp. Run	Energizes compressor motor starter when unit control circuit is energized.
Motor Cooling Solenoid Valve	MCS	None	None	Refrig. Piping	None	Opens to feed liquid refrigerant for motor cooling during compressor operation.
Oil Cooler Solenoid	o c s	None	None	Chiller Piping	None	Opens valve to permit coolant flow during oil pump operation.
Oil Pressure Diff. Switch	OD	50 psig opens	Auto/Man	Lube Box	Oil Press.	Stops compressor when difference between oil and suction pressure drops to setting. Closes at 60 psig to permit compressor start.
Oil Pump Overload	OL	Non-Adjust.	Auto/Man	Lube Box	Oil Press.	Stops oil pump and compressor if oil pump motor overloads electric circuit.
Oil Pump Safety Timer	OPT	60 sec.	Auto/Man	Relay Section	Oil Press.	Stops pump by interrupting safety circuit if vane closed switch fails to close within 60 seconds after oil pump starts.

TABLE 1 Continued. CONTROL COMPONENT SUMMARY – STANDARD APPLICATIONS

CONTROL	SYMBOL	SETTING	RESET (Note 1)	LOCATION	SIGNAL LIGHT	FUNCTION
Oil Pump Time Delay Switch	OTD	60 sec.	None	Relay Section	None	Keeps pump running for 60 seconds after compressor is stopped.
Pushbutton Switch	PB	None	None	Switch Section	None	Pushbutton switches reset the safety circuit when the RESET button on the control panel is pushed.
Prelube Timer	PLT	60 sec.	None	Relay Section	None	Provides a pre-lubrication period for bearings prior to compressor start.
Protective Signal Interlock	PS	None	None	Starter	Ext. Fail	De-energizes system monitor timer when compressor starter closes delta contactor
Phase Voltage Relay	PVR	None	Auto/Man	Starter	Ext. Fail	Protects compressor against damage from single phase, phase reversal or undervoltage.
Range Shift Resistor	RSR	None	None	Control Module	None	Provides temperature range shift for control module on Templifier units.
Capacity Control Solenoid	SA	None	None	Lube Box	Module Red	Part of 4-way solenoid valve. When energized, applies full oil pressure on control piston and closes vanes-UNLOAD.
Capacity Control Solenoid	SB	None	None	Lube Box	Module Green	Part of 4-way solenoid valve. When energized, applies full oil pressure on control piston and opens vanes-LOAD.
Starts Counter	SC	None	None	Panel	None	Counts number of compressor starts
Surgeguard Relay	SGR	Non-Adjust.	Auto/Man	Relay Section	Surgeguard	Works with thermistor to sense impeller cavity temperature. Protects compressor from a surae (CEO63 thru 126).
System Monitor Timer	SM	60 sec.	Auto/Man	Relay Section	Ext. Fail	If compressor fails to start in 60 seconds after system monitor is energized, system monitor terminates start effort.
Sump Oil Thermostat	SOT	104°F	Auto	Control Box	None	On units with refrigerant cooled oil cooler, controls oil sump heater to maintain set temperature.
Sequence Relay	SR	None	None	Field Suooled	None	Relay controlled by system thermostat (or other control) to start unit on call for cooling.
Source Water Thermostat	SWT	Field Set	Auto	Temp. Section	Load Recycle	Stop compressor when water temperature entering evaporator is too low for practical heat recovery.
Anti-Recycle Time Delay Relay	TDR	20 Min.	None	Relay Section	None	Prevents compressor from restarting for 20 minutes after previous shutdown.
Transition Resistor Protector	TRP	None	Auto/Man	Starter	Ext. Fail	Abort compressor starting sequence if starter fails to make transition from star to delta within 1 second.
Pilot Expansion Valve Solenoid	TXS	None	None	Piping	None	Opens when 2nd compressor starts, closes when 2nd compressor stops (PF063 only).
Vane Closed Switch	v c	40 psig Differential	None	Lube Box	Oil Press.	Prevents compressor starting unless capacity control vanes are closed (fully unloaded).
Vane Delay Contacts	VD	None	None	Starter	None	Auxiliary contacts in compressor starter prevent compressor loading and liquid solenoid valves from opening (SEH units only) until compressor motor connected across the line.
Voltage Relay	VR	Non-Adjust.	None	Lube Box	None	Disconnects oil pump motor capacitor after start (CEO50 only).

NOTE #1

Auto-This control automatically resets itself.

Manual-This control requires manual reset which is done mechanically with RESET button

Auto/Man-This control automatically resets itself but electrical lockout circuit requires that RESET button be pushed to reset the circuit.

NOTE #2

This table contains all standard and most optional control components used in McQuay centrifugals. All listed controls are not necessarily used on all units. Controls for specific units can be identified by referring to control diagram and/or the unit control center.

PROTECTIVE CONTROLS

Each McQuay centrifugal is equipped with a complement of safety controls to prevent the compressor from starting under adverse conditions or to take the machine off-line when abnormal or unsafe conditions develop during operation.

In addition, there are a number of relay type devices which operate to assure that the starting, operating and stopping functions are carried out in proper sequence for the protection of the equipment. These relays can be identified on the unit control diagram as R1 R2, etc.

The control panel is equipped with several indicator lights to provide the operator with a quick status condition when the compressor is shut down. With the reference to Figure 3 it will be noted that there are eight safety signal lights to describe some condition which has caused the compressor to be shut down. In a fault condition only one light can be energized at one time.

FIGURE 3. CONTROL PANEL LIGHTS

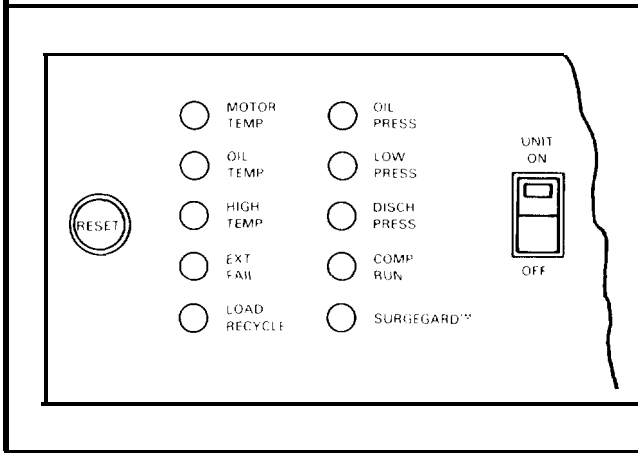

Most of these indicator lights are operated when some abnormal condition exists with the chiller unit. Conditions such as low suction pressure, high discharge pressure, low oil pressure or temperature, high motor winding temperature and surge condition may cause some damage to the equipment if allowed to continue uncorrected.

The troubleshooting guide in Figure 13, page 20, gives the operator a comprehensive list of fault conditions and the probable causes. This guide should be consulted whenever the compressor is shutdown by a protective control.

Each unit is equipped with an "External Failure" light on the control panel. When energized, this signal indicates the compressor cannot run due to a control problem external to the control panel. Faults in the condenser water/chilled water circuits or in the compressor starter could trigger such an external failure signal. This feature helps the operator locate control system problems. Causes and corrective actions are further described in the troubleshooting guide.

The two most severe failures which can occur in a hermetic centrifugal compressor are surge conditions and motor failure. McQuay has developed highly reliable protective systems to guard against both of these failures. An understanding of each will be helpful to the operator in analyzing the unit performance. Both Guardistor and Surgegard are safety protective systems developed by McQuay.

Guardistor Motor Protection-Positive protection against motor overheating is provided by the Guardistor system. The heart of the Guardistor protective circuit are the thermistors embedded in the motor windings to sense motor winding temperature. When the motor temperatures are normal, the thermistors have low resistance which remains nearly constant up to a predetermined critical temperature. At this temperature, a sharp increase in resistance causes the Guardistor relay to drop out and cause the control circuit to stop the compressor. Such failure causes a lockout mode requiring manual reset.

Surgegard-McQuay uses Surgegard to sense the occurrence of surge condition and to stop the compressor before the machine is damaged. The Surgegard relay will also prevent the compressor from restarting until the cause of the malfunction has been corrected. Possible causes for surge, or rotating stall condition, may be dirty condenser tubes or cooling tower or pump malfunction, which acts to elevate the system's head. The Surgegard relay is the safety control for the PEH/PHH 063 and larger chillers. In the PEH/PHH050 the high temperature thermostat provides this safety function. These controls are factory set and require no field adjustment.

SAFETY CONTROL RESET

Certain safety controls in the PEH/PHH control panel will lock out automatically when operating conditions exceed trip settings. As an example, if the refrigerant discharge pressure leaving the compressor exceeds the trip setting of the high pressure cutout switch, the compressor will be taken off-line and cannot be restarted until the pressure has returned to normal and the high pressure cutout has been manually reset.

In the standard control center several other safety functions also lock out under abnormal operating conditions. These controls include the low pressure cutout, high discharge temperature thermostat, high oil temperature switch, low oil pressure, high suction temperature (PEH/PHH050 only), Surgegard (PEH/PHH063-126) and external system failure.

Each of these fault signals can be identified by the control panel lights and all can be reset with the single RESET button on the front of the control panel when the fault has been corrected.

In the event of electrical system power interruption, the standard PEH/PHH units will lock out and will not restart automatically. The EXT. FAIL light will go on when power is restored and the RESET button must be manually reset to restore automatic chiller operation.

FIGURE 4. CONTROL CENTER

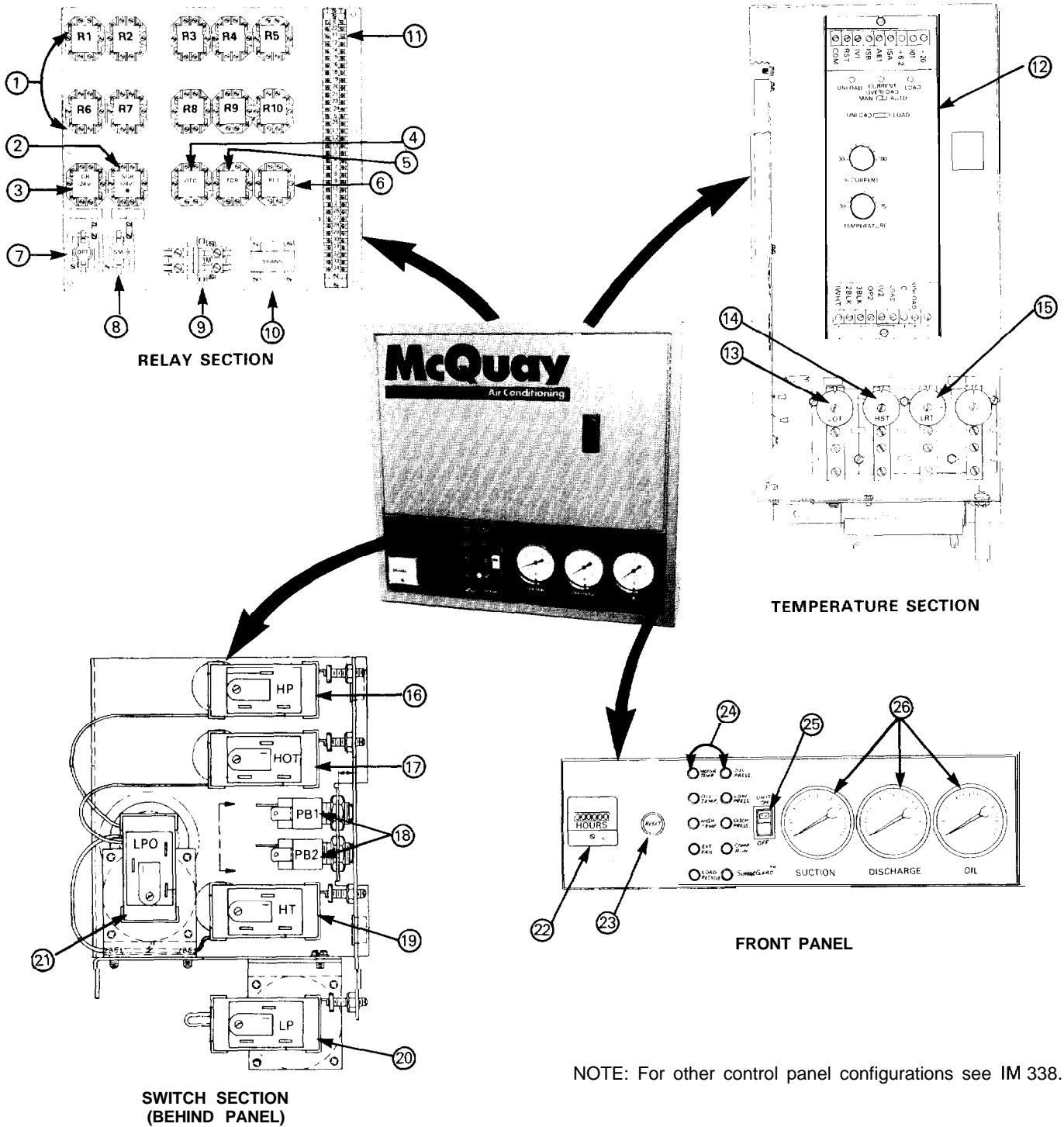

NOTE: For other control panel configurations see IM 338.

Legend

- | | | |
|----------------------------------|-------------------------------------|---------------------------------------|
| 1. Operating Relays R1-R10 | 10. Control Transformer | 19. High Discharge Temperature Switch |
| 2. Surgegard Relay | 11. Terminal Strip | 20. Low Pressure Switch |
| 3. Guardistor Relay | 12. Control Module | 21. Low Pressure Override Switch |
| 4. Oil Pump Time Delay Switch | 13. Low Oil Temperature Thermostat | 22. Hour Meter |
| 5. Anti-Recycle Time Delay Relay | 14. High Suction Temperature Switch | 23. Reset Button |
| 6. Prelube Timer | 15. Load Recycle Thermostat | 24. Indicator Lights |
| 7. Oil Pump Safety Timer | 16. High Pressure Switch | 25. Unit ON/OFF Switch (with light) |
| 8. System Monitor Timer | 17. High Oil Temperature Switch | 26. Gauges |
| 9. Oil Pump Contactor | 18. Push Button Switches | |

CONTROL CENTER

The control panel and compressor lube box contain most of the operating and protective controls. The control center is completely prewired and most adjustable controls have been set during the factory test procedure.

Inspection of the control panel will reveal that it is divided into three functional sections as shown in Figure 4.

TEMPERATURE SECTION

The temperature section contains the control module and several thermostats with adjustments accessible with the panel door open.

RELAY SECTION

The relay section is located behind the large left front door with the McQuay logo. This section contains the operating and safety relays and wiring terminal strip. Most relays are plug-in type and can easily be removed for servicing.

SWITCH SECTION

Mounted in the lower section front panel are pressure gauges, indicator lights, RESET button and the unit ON/OFF switch. Behind this front panel is the switch section containing several safety/operating switches and the reset pushbutton switches,

CONTROL MODULE

The McQuay solid-state capacity control module provides temperature control and current limit control and is equipped with several auxiliary features which provide the operator with considerable flexibility in system control.

Two switches provide the operator with the options of automatic or manual load/unload control. The switch positions are:

AUTO This position provides for automatic operation of the control module to load or unload the compressor to control water temperature leaving the chiller.

MAN . Disconnects the automatic temperature control functions to permit manual control.

LOAD With switch in MAN, the SB loading solenoid can be manually energized.

UNLOAD .With switch in MAN, the SA unloading solenoid can be manually energized.

Indicator lights on the module will function as follows: Red will light during unloading control action, green will light during loading and amber will light when the load action is overridden by the current limit control. Red and green cannot light simultaneously nor can amber and green. Red and amber indicate current limit has been exceeded by 5% of full load and will signal "unload" until current is reduced to the setpoint. Current limit will override manual load control.

A pulse rate adjustment is provided on the control module to provide a means of matching load or unload speed to suit the system size. Pulse rate can be set over the range of 2 to 25 pulses per minute and is effective only when the chilled water temperature is within 4° F of setpoint. In a large volume chilled water system a lower pulse rate (i.e., 8 pulses/minute) will provide adequate control response. Conversely a higher pulse rate in a small volume system will allow

FIGURE 5. CONTROL MODULE

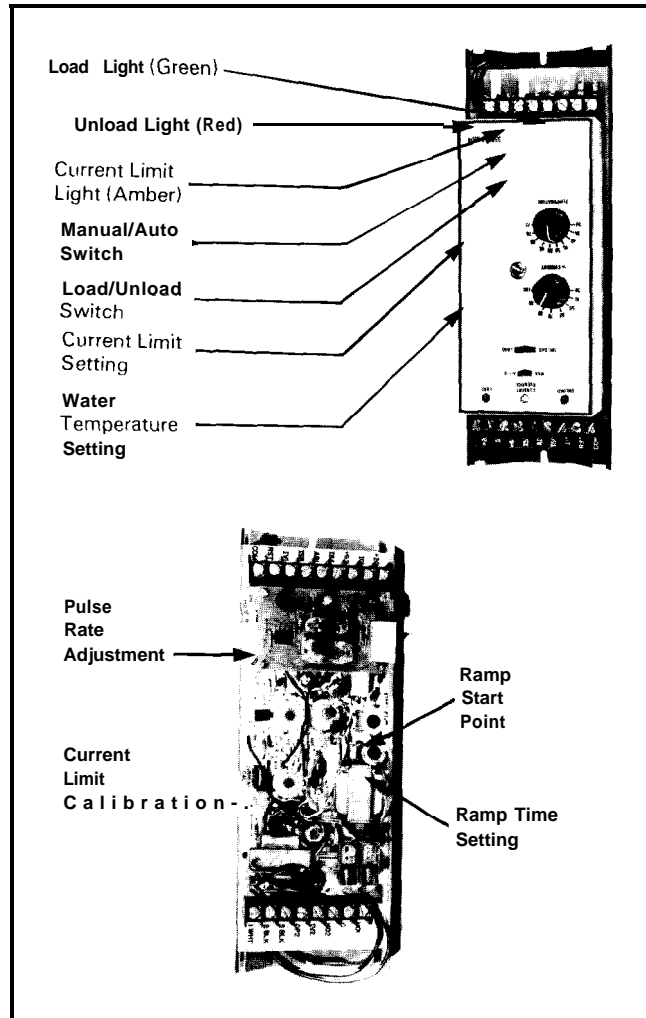

the control to react quickly to temperature changes.

The controller is also equipped with a Ramp-up function which can be adjusted to control the loading of a compressor at start-up. The Start Point setting determines the point at which controlled loading begins; the Ramp Time setting establishes the time of controlled loading.

The adjustment knob marked "% Current" would normally be positioned at 100% to permit the compressor to fully load. If the operator desires to limit the motor amperes or compressor capacity for any reason, this control can be set to limit the motor current to any point between 30% and 100%.

The "Temperature" knob permits setting the chilled water control point to the desired temperature.

Setting and calibration procedures for all functions of the control module are detailed in the adjustments section of this manual.

CAPACITY CONTROL SYSTEM

The compressor capacity is controlled by the movement of the inlet vanes, opening or closing to permit the correct quantity of refrigerant to enter the wheel or impeller. The vane movement occurs in response to oil flow from the SA or SB solenoid valve which, in turn, respond to a control module signal. This oil flow activates a piston to rotate the vanes.

VANE OPERATION

The hydraulic system for the vane control operation consists of a 4-way normally open solenoid valve. Oil under pressure is directed by the 4-way valve to either or both sides of the piston depending on whether the control signal is to load, unload or hold.

To open the vanes (or load the compressor) solenoid "SA" is de-energized and solenoid "SB" is energized, allowing oil flow from port SA to one side of the piston then drain through port SB.

To close the vanes (unload compressor) valve SB is de-energized and valve SA is energized to move the piston and vanes to unload position.

When both solenoid valves SA and SB are de-energized, full oil pressure is directed to both sides of the piston through ports SA and SB, thus the vanes are held in that position. Refer to Figure 7 for solenoid action. Note that both solenoids cannot be energized simultaneously.

METERING VALVES

The speed at which the capacity control vanes are opened or closed can be adjusted to suit system operating requirements. Adjustable needle valves in the oil drain lines

are used to control the rate of bleed-off and consequently the "vane speed". These needle valves are part of the 4-way solenoid valve assembly located in the compressor lube box (Figure 6).

The valves are normally factory set so the vanes will move from fully closed to fully open in approximately 3 minutes and from fully open to fully closed in 1 minute (except CE126). The speed should be slow enough to prevent over-controlling and hunting. For adjustment procedure, refer to the Adjustments section of this manual

FIGURE 6. LUBE BOX

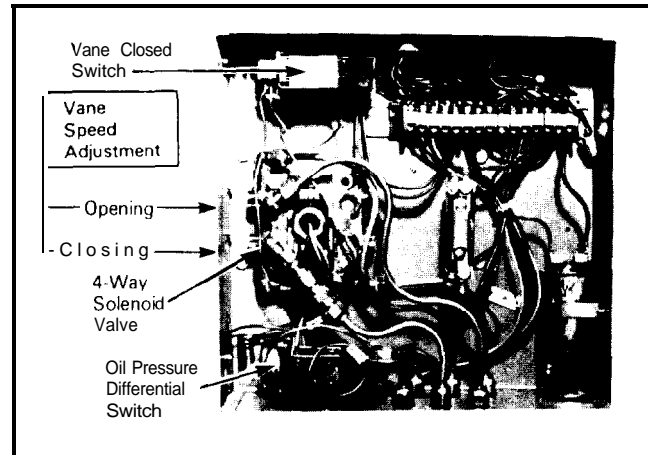

FIGURE 7. VANE CONTROL SOLENOID OPERATION

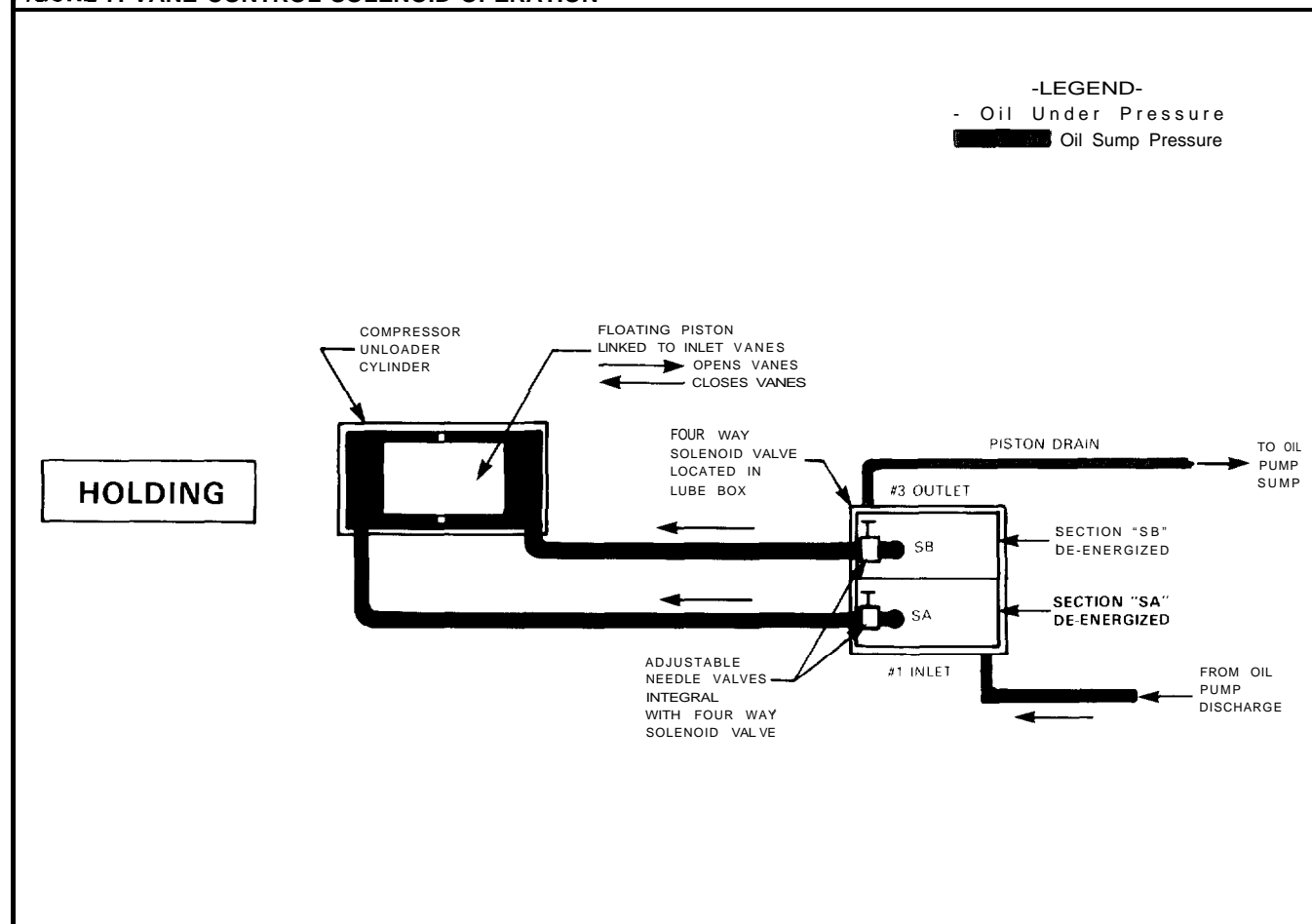
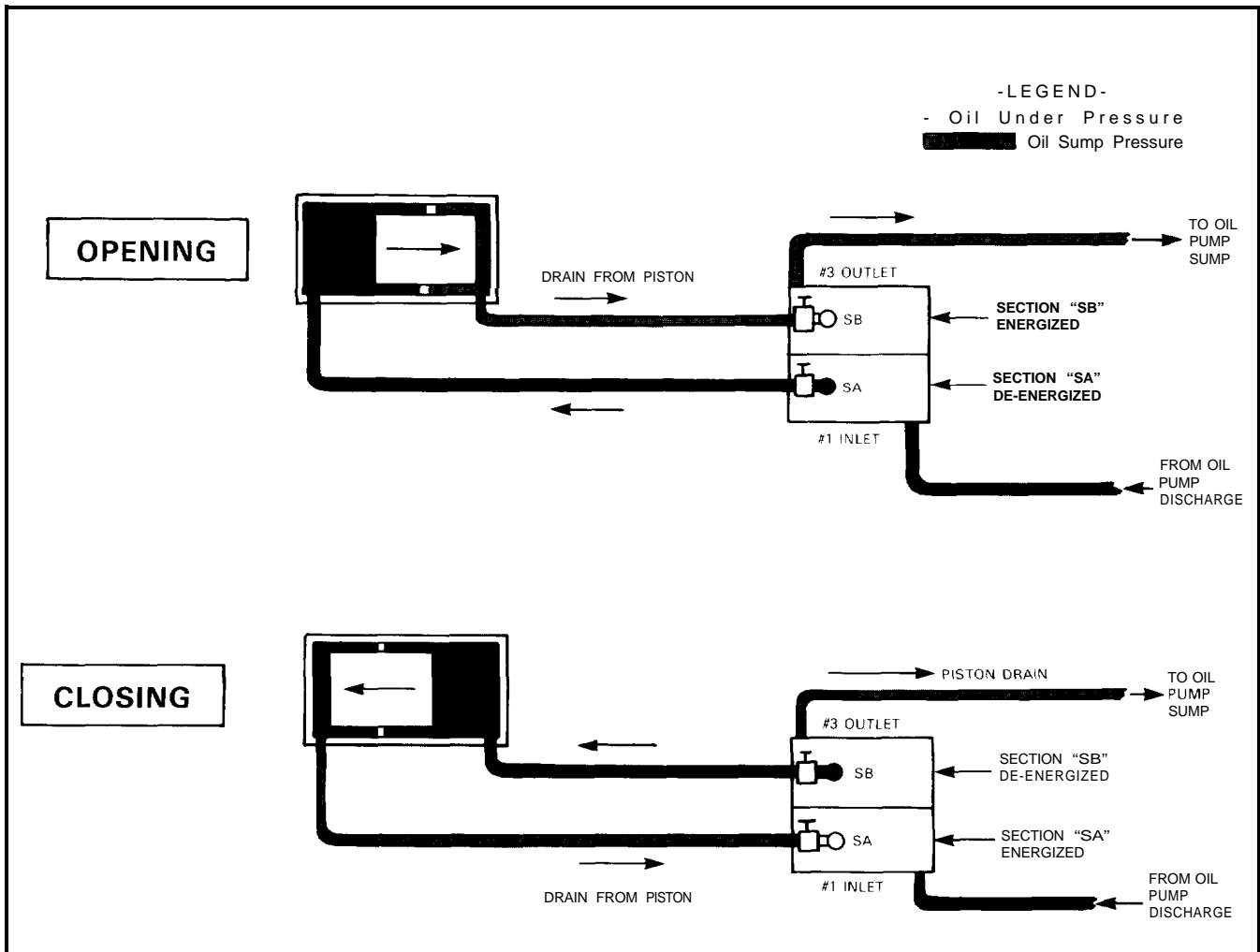

FIGURE 7. VANE CONTROL SOLENOID OPERATION, CONTINUED



OIL SYSTEM

The oil system for the PEH/PHH units provides lubrication and heat removal for the compressor bearings and internal parts. In addition, the system provides oil under pressure to hydraulically operate the piston for positioning the inlet guide vanes for capacity control.

Proper operation of the hydraulic system and bearing lubrication system can be assured only if McQuay recommended oil is used. For proper oil selection, consult Figure 8. Each unit is factory charged with the proper oil. Under normal operation, no additional oil should be needed.

The oil pump for the CE050 compressor is completely self-contained within the compressor housing. The assembly includes the pump, pump motor, oil heater and oil separator. The oil is pumped through the oil discharge line to the oil filter in the compressor casting and then to the refrigerant-cooled oil cooler.

The other compressor sizes-CE063, 079, 087, 100 and 126-utilize a separate oil pump contained in its own oil reservoir. This assembly includes pump, motor, heater and oil separator. Oil is pumped through the discharge line, through the external oil cooler and then to the oil filter inside the compressor housing. Standard PEH/PHH 063-126 units utilize a water-cooled oil cooler although an optional refrigerant-cooled oil cooler is available.

The oil coolers serve to maintain the proper oil temperature under normal operating conditions. The coolant flow control valve should maintain 90° F-100° F oil temperature leaving

the oil cooler for optimum operation of the oil system.

Bearings are supplied with oil through internally drilled passages within the compressor assembly. The oil drains from the bearings into the gear housing and is gravity returned to the oil sump.

FIGURE 8. OIL FOR CENTRIFUGAL COMPRESSORS

Compressor Size	Oil Type	Oil Viscosity @ 100° F
CE050 CE063 CE079 CE087	SUNISO 4GS or Texaco Capella 68 WF	SUNISO 5GS or Texaco Capella 100 WF
CE100 CE126	SUNISO 5GS or Texaco Capella 100 WF	Texaco Regal 150

The oil heaters in the gear case and in the oil pump reservoir must remain energized whenever the compressor is off. IN THE EVENT OF POWER LOSS TO THE HEATERS ALLOWING THE OIL TO COOL, THE HEATERS SHOULD BE ENERGIZED FOR 24 HOURS PRIOR TO STARTING THE COMPRESSOR.

A low oil temperature thermostat (LOT) in the control center prevents the oil pump from starting with cold oil. This thermostat should be set as high as ambient conditions will allow.

This is an automatic reset device and, when tripped, will cause the OIL TEMP light to glow. The RESET button must be pushed for restart.

The compressor is equipped with lubrication protection for coast down in the event of a power failure. This is accomplished by the use of a spring loaded piston in models

CEO50 thru 100. When the oil pump is started, the piston is forced back by oil pressure, compressing the spring and filling the piston cavity with oil. When the pump stops, the spring pressure on the piston forces the oil out to the bearings.

In model CE126 the compressor coast down lubrication is supplied from a gravity feed lube reservoir.

HOT GAS BYPASS

The PHH heat recovery chillers are equipped with a hot gas bypass system used to feed discharge gas directly into the evaporator when the system load falls below 10% of the compressor capacity.

Light load conditions are signaled by a thermostat (HGT)

sensing return water temperature entering the evaporator. This thermostat energizes the hot gas solenoid (HGS). This introduction of hot gas provides a stable refrigerant flow and keeps the machine from short cycling under light load conditions. It also prevents surge during heat recovery operation.

OPERATING THE CHILLER

The initial startup of the McQuay centrifugal chillers after all installation is complete must be performed by a factory trained McQuay Service technician.

The following procedures apply to normal daily operation of the equipment, assuming that the chiller will be secured during periods when the building is unoccupied. In cases of continuous operation, the operator should make operational checks on the equipment at least once each day.

PRELIMINARY CHECKS BEFORE STARTING

Prior to attempting to start the chiller, the operator should make a series of routine checks of the equipment to assure that all components are ready for operation.

1. Assure that power has been on to the oil heaters since shutdown. An EXT FAIL light on will signal if power has been interrupted and has been restored.

FIGURE 9. PEH079 CHILLER (REAR VIEW)

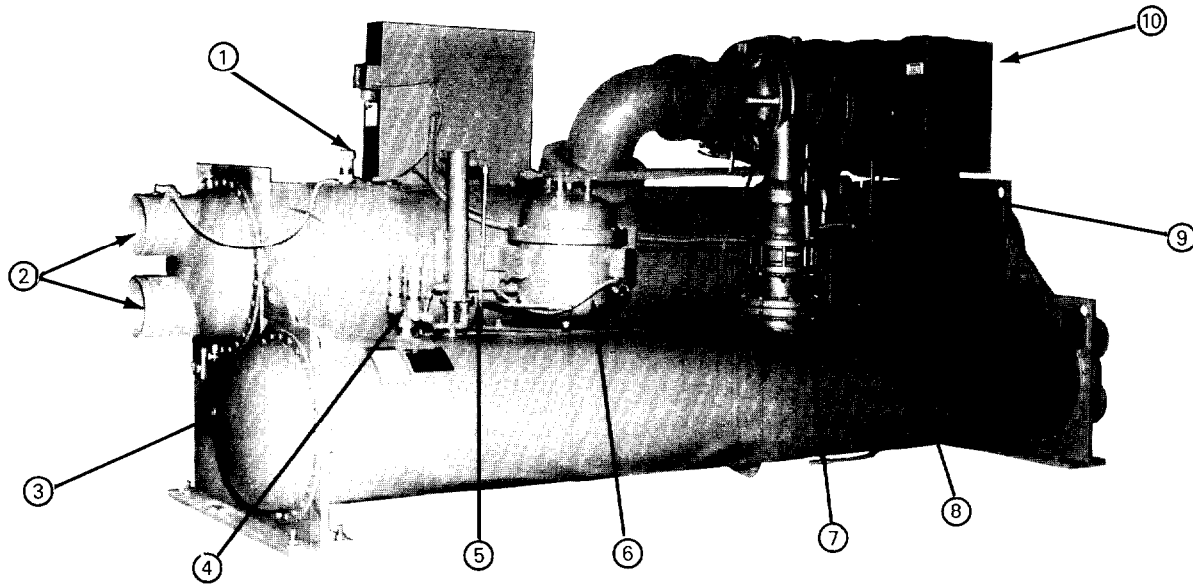

LEGEND

- | | |
|-------------------------------------|-----------------------------------|
| 1. Evaporator Pressure Relief Valve | 6. Oil Pump Assembly |
| 2. Chilled Water Connections | 7. Discharge Line Check Valve |
| 3. Oil Cooler Water Connections | 8. Lube (Control Box) |
| 4. Condenser Pressure Relief Valves | 9. Motor Cooling Feed Line |
| 5. Oil Cooler | 10. Compressor Motor Terminal Box |

2. Check oil sump by hand touch to see that oil heaters have been energized during the shutdown. Check position of all valves to assure valves are open.
3. Verify that all condenser and chilled water valves are in proper starting mode.
4. All safety indicator lights on the control panel should be out for proper starting mode. If any light is on, consult the Troubleshooting Guide.
5. Visually check the oil level in the sightglass. In the PEH/PHH050 units, this sightglass is in the front end of the compressor; all larger units have this sightglass as part of the oil pump.

STARTING THE CHILLER

1. Start the chiller water pump and verify that proper flow has been established.
2. Position the ON-OFF switch on the control panel to the ON position. A self-contained light will glow.
3. Assuming that the chilled water temperature is above the setting of the Load Recycling Thermostat and the unit has been off more than 20 minutes, the pump will start.
4. After the 60 second prelube operation of the oil pump, the condenser water pump will be started. As soon as all interlocks verify condenser water flow, the compressor will

be started and the COMP RUN light on the control panel will glow.

5. The control module will take over load/unload functions in response to chilled water temperature. Normally, the compressor will load to full load according to the settings of the control module ramp-up control.

OPERATING CHECKS

1. While operating under automatic control, the operator should observe the discharge, suction, and oil pressure and verify that these pressures are normal. For R12 units, discharge pressure can range from 90 psig to 150 psig and suction pressure from 35 psig to 50 psig, depending on load conditions and system operating characteristics. Check the operating refrigerant pressures against design conditions. Oil pressure must be 50 psig above suction pressure to keep the compressor on line. Normal oil pressures are: CEO50 — 150 to 175 psig; CE063,079,087, 100 — 120 psig; and CE126 — 100 psig. All pressures are oil gauge reading minus suction gauge reading.
2. Observe the loading and unloading of the compressor by the red and green lights on the control module. If short cycling, refer to the Troubleshooting Guide and take corrective action.
3. Each time the compressor is shut down on control of the Load Recycle Thermostat, the LOAD RECYCLE light will

FIGURE 10. PEH126 CHILLER

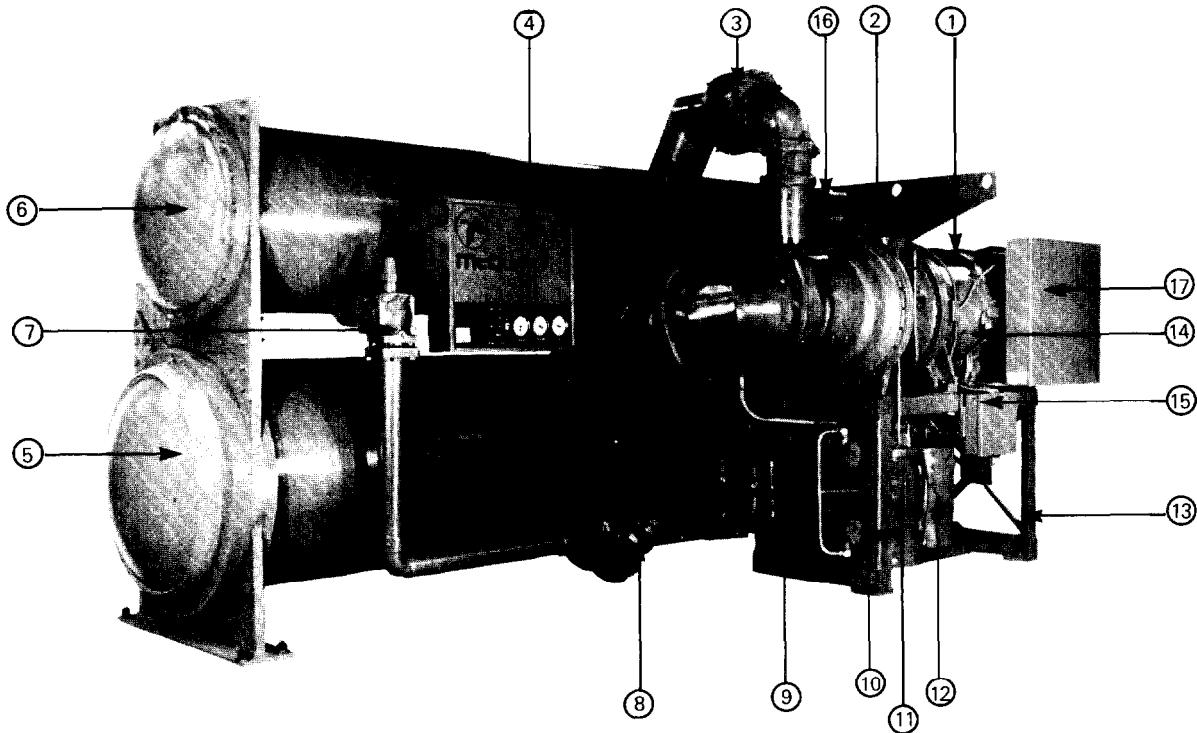

LEGEND

- | | | |
|--------------------------|------------------------------|-------------------------------------|
| 1. CE126 Compressor | 7. Liquid Line Shutoff Valve | 13. Compressor Support |
| 2. Oil Filter | 6. Expansion Valve | 14. Motor Cooling Liquid Line |
| 3. Discharge Check Valve | 9. Oil Coolers | 15. Lube Box |
| 4. Control Panel | 10. Oil Pump | 16. Relief Valves |
| 5. Evaporator | 11. Oil Level Sightglass | 17. Compressor Motor Terminal Cover |
| 6. Condenser | 12. Oil Reservoir | |

glow, if all other conditions are normal.

4. Once the chilled water temperature has stabilized and the compressor is intermittently loading or unloading at less than full load, compare the water temperature with the module setpoint. If different, consult the Troubleshooting chart.
5. Occasionally check the panel lights. The compressor should not run if any of the eight safety lights are energized.

SHUTDOWN

Stopping the unit at night or for weekends can be easily accomplished by switching the ON-OFF switch on the control panel to the OFF position. The switch light will go out and

the compressor will stop.

The oil pump will continue operating for 60 seconds after the compressor starter is de-energized to assure lubrication to compressor bearings during spin-down.

Once the switch is turned off, the compressor cannot be restarted unless the switch is repositioned.

If the operator has the need to secure the chiller and prohibit starting by unauthorized personnel, removal of relay R7 from its plug-in base in the control panel will open the protective circuit and immobilize the unit. In this condition, none of the control panel lights are energized and the oil heater circuit is still operative. Relay R7 is identified in Figure 4, page 8. When relay R7 is replaced, the EXT. FAIL light will come on and the RESET button must be pushed to restore the safety circuits to the operating mode.

FIGURE 11. PHH063 CHILLER (REAR VIEW)

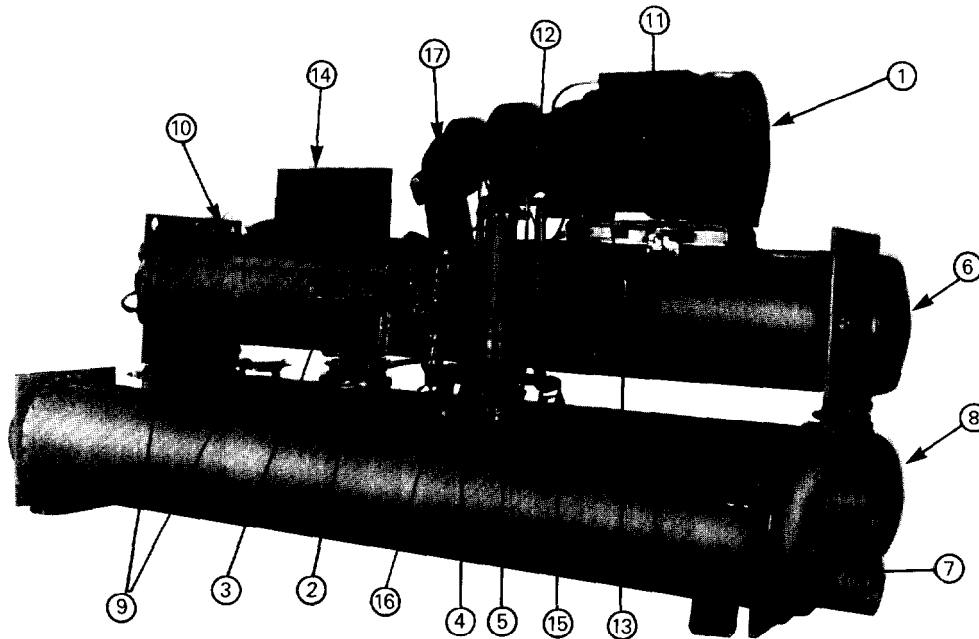

LEGEND

- | | | |
|--------------------------|-----------------------------|-------------------------------|
| 1. CEO63 Compressor | 7. Heat Rejection Condenser | 13. Lube Box |
| 2. Oil Pump | 8. Heat Recovery Condenser | 14. Control Panel |
| 3. Oil Cooler | 9. Condenser Relief Valves | 15. Motor Cooling Liquid Line |
| 4. Hot Gas Bypass | 10. Evaporator Relief Valve | 16. Expansion Valve |
| 5. Discharge Check Valve | 11. Motor Terminal Cover | 17. Compressor Suction Line |
| 6. Evaporator | 12. Oil Filter | |

MAINTENANCE

ROUTINE MAINTENANCE

LUBRICATION (See CAUTION)

After the system is once placed into operation, no other additional oil is required except in the event that repair work becomes necessary to the oil pump or unless a large amount of oil is lost from the system due to a leak.

If oil must be added with the system under pressure, use a hand pump with its discharge line connected to the service valve at the bottom of the oil pump. (The CEO50 compressor with its internal oil pump is equipped with an oil service valve on the compressor).

CHANGING OIL FILTERS (See CAUTION)

CEO50 Compressors-If the unit is equipped with a suction line service valve, close this valve and close the valve on the motor cooling liquid line to isolate the compressor. Vent the refrigerant pressure from the compressor. Remove the filter cover and the old filter and install the new filter, open end first. Replace the cover using a new gasket. Reopen the suction and liquid line valves.

If the unit is not equipped with a suction line service valve, the unit will have to be pumped down in order to remove the pressure in the compressor before removing the cover and changing the filter. Refer to later section for pumpdown procedure.

CEO63 and Larger Compressors-The oil filter in each of these machines can be changed by simply isolating the filter cavities. Close the oil discharge line service valve at the oil pump (at the filter on CE126). Remove the filter cover; some foaming may occur but the check valve should limit leakage from other compressor cavities. Remove the filter, replace with new element and replace filter cover using new gasket. Reopen valve in pump discharge line.

When the machine is operated again, the oil level should be checked to determine if oil needs to be added to maintain proper operating level.

CAUTION

Improper servicing of the lubrication system, including the addition of excessive or incorrect oil, substitute quality oil filter, or mishandling of the equipment under pressure is hazardous. Only authorized and trained service personnel should attempt this service. For qualified assistance, contact your local McQuay Service technician.

REFRIGERANT CYCLE

Maintenance of the refrigerant cycle consists of maintaining a log of the operating conditions, and assuring the unit has the proper oil and refrigerant charge.

At every inspection, the oil, suction and discharge pressures should be noted and recorded, as well as condenser and chiller water temperatures.

The suction line temperature at the compressor should be taken at least once a month. Subtracting from this, the saturated temperature equivalent of the suction pressure will

give the superheat. Extreme changes in superheat over a period of time will indicate losses of refrigerant or possible deterioration of the expansion valves. Proper superheat setting is 2° to 6°F at full load.

ELECTRICAL SYSTEM

Maintenance of the electrical system involves the general requirement of keeping contacts clean and connections tight and checking on specific items as follows:

1. The compressor current draw should be checked and compared to nameplate RLA value. Normally the actual current will be lower since the nameplate rating represents full load operation. Also check all pump and fan motor amperages and compare with nameplate ratings.
2. Inspection should verify that the oil heaters are operative. The heaters are insert cartridge type and can be checked by ammeter reading. They should be energized whenever power is available to the control circuit (whenever compressor is inoperative). When the compressor starts the heaters are de-energized.
3. At least once a year, all safety controls except compressor overloads should be made to operate and their operating points checked. Any control may shift its operating point as it ages, and this must be detected so the controls can be readjusted or replaced. Pump interlocks and flow switches should be checked to assure they interrupt the control circuit when tripped.
4. Contactor in the motor starter should be inspected and cleaned annually. Tighten all terminal connections.
5. The compressor motor resistance to ground should be checked and logged annually. This log will track insulation deterioration. A reading of 5 megohms or less indicates possible insulation failure and should be further checked.
6. The centrifugal compressor must rotate in the direction indicated by the arrow on the casting near the rotation sightglass. If the operator has any reason to suspect that the power system connections may have been altered, the compressor should be jogged to check rotation. For assistance, call McQuay Service.

CLEANING AND PRESERVING

A common cause of service calls and equipment malfunction is dirt. This can be prevented with normal maintenance. The system components most subject to dirt are:

1. Permanent or cleanable filters in the air handling equipment must be washed in accordance with the manufacturer's instructions; throwaway filters should be replaced. The frequency of this service will vary with each installation.
2. Remove and clean strainers in chilled water system, oil cooler line and condenser water system at every inspection.

SEASONAL SERVICING

Prior to shutdown periods and before starting again, the following service procedures should be completed.

ANNUAL SHUTDOWN

1. Where freezing temperatures may be encountered, the condenser and chiller water piping should be disconnected

from the supply and drained of all water. Dry air blown through the condenser will aid in forcing all water out. Removal of condenser heads is also recommended. The condenser and evaporator are not self-draining. Water permitted to remain in the piping and vessels will rupture these parts if subjected to freezing temperature.

FORCED CIRCULATION OF ANTIFREEZE THROUGH THE WATER CIRCUITS IS THE ONLY SURE METHOD OF AVOIDING TROUBLE.

2. Take measures to prevent the shutoff valve in the water supply line from being accidentally turned on.
3. If a cooling tower is used and if the water pump will be exposed to freezing temperatures, be sure to remove the pump drain plug and leave it out so that any water which may accumulate will drain away.
4. Open compressor disconnect switch, and remove Fusetrons. If transformer is used for control voltage, the disconnect must remain on to provide power to oil heater. Set compressor switch to OFF position. To insure against the possibility of an accidental start, remove relay R7 in each control panel.
5. Check for corrosion and clean and paint rusted surfaces.
6. Clean and flush water tower for all units operating on a water tower. Make sure tower "blowdown" or bleedoff is operating. Set up and use a good maintenance program to prevent "liming up" of both tower and condenser. It should be recognized that atmospheric air contains many contaminants which increase the need for proper water treatment. The use of untreated water may result in corrosion, erosion, sliming, scaling or algae formation. It is recommended the service of a reliable water treatment is required-McQuay assumes no responsibility for the results of untreated or improperly treated water.
7. Remove condenser heads at least once a year and clean condenser tubes.

ANNUALSTARTUP

A dangerous condition can exist if power is applied to a faulty compressor motor starter which has been burned out. This condition can exist without the knowledge of the person starting the equipment.

This is a good time to check all the motor winding resistance to ground. Annual checking and recording of this resistance will provide a record of any deterioration of the winding insulation. All new units have well over 100 megohms resistance between any motor terminal and ground.

Whenever great discrepancies in readings occur or uniform readings of less than 5 megohms are obtained, the motor cover should be removed for inspection of the winding prior to starting the unit. Uniform readings of less than 5 megohms indicate motor failure is imminent and motor should be replaced or repaired. Repair before failure occurs can save a great deal of time and labor expended in the cleanup of a system after motor burnout.

1. The control circuit should be energized at all times. If the control circuit has been off and oil is cool, energize oil heaters and allow 24 hours for heater to remove refrigerant from the oil before starting.
2. Check and tighten all electrical connections.
3. Replace the drain plug in cooling tower pump if it was removed at shutdown time the previous season.
4. Install Fusetrons in main disconnect switch (if removed).
5. Reconnect water lines and turn on supply water. Flush out condenser and check for leaks.
6. Refer to the procedures of "Preliminary Checks Before Starting" before energizing the compressor circuit.

REPAIR OF SYSTEM

PUMPING DOWN

If it becomes necessary to pump the system down, extreme care should be used to avoid damage to the water chiller due to freezing. Always make sure that full water flow is maintained through the chiller while pumping down. To pump system down, close all liquid line valves. With all liquid line valves closed and water flowing through chiller, start the compressor. In order to pump system down as far as possible, it will be necessary to bypass the low pressure override switch and jumper the low pressure cutout. Set temperature module to manual load position. Vanes must be open while pumping down to avoid a surge or other damaging condition.

Operate machine until the suction pressure stabilizes at approximately 20 to 25 psig.

Stop the machine. Allow pressure to buildup. Repeat this procedure 3 times.

After the system has been pumped down, the gas pressure remaining will have to be purged before the machine can be serviced.

PRESSURE TESTING

No pressure testing is necessary unless some damage was incurred. After repairs are made, pressure test the system at a pressure that does not exceed the standby pressure in the condenser. (A test pressure higher than condenser pressure would open the discharge check valve and allow flow of test pressure into condenser). In cases where the entire refrigerant charge is lost, refer to the following paragraphs. The evacuation procedure can be followed in both cases.

LEAK TESTING

In case of the loss of the entire refrigerant charge, the unit should be checked for leaks prior to charging the complete system. This can be done by charging only enough refrigerant into the system to build the pressure up to approximately 10 psig and adding sufficient dry nitrogen to bring the pressure up to a maximum of 125 psig and then leak test with Halide or electronic leak detector. CAUTION: DO NOT USE OXYGEN TO BUILD UP PRESSURE AS A SERIOUS EXPLOSION CAN RESULT. A pressure regulating valve should always be used on the drum being used to build the system pressure. Also, do not exceed the test pressure given above. When the test pressure is reached disconnect the gas cylinder.

If any leaks are found in welded or silver soldered joints or if it is necessary to replace a gasket, relieve the test pressure in the system before proceeding. For copper joints, silver solder is recommended.

After making any necessary repair, the system should be evacuated as described below.

EVACUATION

After it has been determined that there are no refrigerant leaks, the system should be evacuated using a vacuum pump with a capacity of approximately 3 cu. ft/min. and that will reduce the vacuum to at least 1 millimeter (1000 microns).

A mercury manometer, electronic or other type of micron gauge should be connected at the farthest point from the vacuum pump. For readings below 1 millimeter, the electronic or other micron gauge should be used.

The triple evacuation method is recommended and is particularly helpful if the vacuum pump is unable to obtain the desired 1 millimeter of vacuum. The system is first evacuated to approximately 29 inches of mercury. Enough refrigerant vapor is then added to the system to bring the pressure up to zero gauge pressure. Then the system is once again evacuated to approximately 29 inches of mercury. This is repeated 3 times. The second pull down will remove about 90% of that remaining from the first pull down and after the third, only 1/10 of 1% non-condensables will remain.

REFRIGERANT CHARGING

The McQuay centrifugal chillers normally use R-12, or R-500 refrigerant; therefore, it is recommended that the operator check the unit nameplate to assure the correct refrigerant selection prior to charging or adding refrigerant.

An initial operating charge is made at the factory prior to shipment. In the event the operator needs to add refrigerant after the unit is installed, certain precautions should be taken to protect equipment components. Refrigerant charging lines must be kept dry, clean and free of non-condensable gases. Care should be taken in selecting the best charging point in the unit so as to protect the equipment from damage.

If the entire charge is lost or removed from the unit, recharging can be accomplished quickly and safely by introducing the liquid refrigerant directly into the bottom of the evaporator

with the expansion valve manually opened. Both condenser water and chilled water must be flowing through the respective vessels to prevent localized freezing. Consult the chiller nameplate for the proper refrigerant charge.

With a near-normal charge in the system, final charging can best be accomplished with the unit running with the compressor at full load. In this operating mode the unit should be charged until suction superheat is between 2° and 6°F, adjusting the thermal expansion valve as necessary. Continue charging until 9° to 11 °F liquid subcooling is obtained leaving the condenser if the unit is operating at full load. At less than full load, liquid subcooling will be proportionally less.

PRESSURE RELIEF VALVE REPLACEMENT

Current condenser designs use two relief valves (1 set) separated by a three-way shutoff valve. In the event one of the relief valves is leaking on the two valve set, the following procedures should be followed:

If the valve closest to the valve stem is leaking, back seat the three-way valve all the way, closing the port to the leaking pressure relief valve. Remove and replace the faulty relief valve. The three-way shutoff valve should remain either fully back seated or fully forward for normal operation. If the relief valve furthest from the valve stem is leaking, front seat the three-way valve and replace the relief valve and replace the relief valve as stated above.

EQUIPMENT WARRANTY

Each PEH/PHH centrifugal chiller manufactured by McQuay carries a standard limited warranty. This warranty covers repair or replacement of component parts which prove defective in material or workmanship within 12 months from initial

startup or 18 months from date shipped by the company, whichever comes first.

For a complete description of this warranty refer to the warranty form furnished with the equipment.

REFRIGERANT CHARTS

FIGURE 12.

°F	PSIG	°F	PSIG	°F	PSIG	°F	PSIG
4	12.3	45	42.6	86	93.3	127	171.4
6	13.5	46	44.6	88	96.5	129	176.2
10	14.6	49	46.7	90	99.8	131	181.0
12	15.8	52	48.8	93	103.1	134	186.0
14	17.1	54	51.0	94	106.5	136	191.0
16	18.4	56	53.1	95	110.0	138	196.1
18	19.7	58	55.4	96	113.5	140	201.3
20	21.0	60	57.7	100	117.2	144	206.6
22	22.4	62	60.1	102	120.9	146	212.0
24	23.9	64	62.5	104	124.6	148	217.5
26	25.4	66	65.0	106	128.5	148	223.1
28	26.9	68	67.6	108	132.4	146	228.8
30	28.4	70	70.2	110	136.4	150	234.6
32	30.1	72	72.9	112	140.5	152	240.5
34	31.7	74	75.6	114	144.7	154	246.5
36	33.4	76	78.4	116	148.9	155	252.6
38	35.2	78	81.2	118	153.2	158	258.8
40	37.0	80	84.2	120	157.6	160	265.1
42	38.8	82	87.2	122	162.1	162	271.5
44	40.7	84	90.2	124	166.7	164	278.1

1	8.8	3	37.9	5	88.6	13	169.0
3	9.9	4	39.9	6	91.8	14	173.9
4	11.0	5	41.9	7	95.1	15	179.0
5	12.1	6	43.9	8	98.5	16	184.2
6	13.3	7	46.1	9	102.0	17	189.4
7	14.5	8	48.2	10	105.6	18	194.8
8	15.7	9	50.5	11	109.2	19	200.2
9	17.0	10	52.8	12	112.9	20	205.8
10	18.4	11	55.1	13	116.7	21	211.5
11	19.7	12	57.6	14	120.6	22	217.2
12	21.2	13	60.1	15	124.6	23	223.1
13	22.6	14	62.6	16	128.6	24	229.1
14	24.1	15	65.2	17	132.7	25	235.2
15	25.7	16	67.9	18	136.9	26	241.4
16	27.3	17	70.6	19	141.2	27	247.7
17	28.9	18	73.5	20	145.6	28	254.2
18	30.6	19	76.3	21	150.1	29	260.7
19	32.4	20	79.3	22	154.7	30	267.4
20	34.2	21	82.3	23	159.4	31	274.2
21	36.0	22	85.4	24	164.1	32	281.1

ADJUSTMENTS

ADJUSTING AND CALIBRATING

CURRENT LIMIT CALIBRATION

The current limit feature of the control module functions to limit the maximum compressor motor current and is set at 100% amperes with the compressor at full load. The following procedure will properly set this feature:

1. Remove the cover from Control Module. (See Figure 5).
2. Place the AUTO/MAN switch in MAN position. This switch position effectively disconnects the temperature control function and permits manual loading and unloading of the compressor.
3. Adjust the Ramp Up Start Point to 100 (fully counterclockwise) and set Ramp time to MIN.
4. Rotate Percent Current knob fully clockwise.
5. Using the LOAD/UNLOAD switch, manually load the compressor until the motor current is at rated load amperes. (Refer to RLA on compressor nameplate).
6. With full load current on the motor, adjust the blue CURRENT CAL. potentiometer in a clockwise rotation until the amber light on the module comes on. If the red unload light comes on, back off the setting until only the amber light is lit. A quick check can be made with a voltmeter across terminals OP2 and COM of the module. This voltage should be about 10 VDC.
7. Stop compressor, rotate metal indicator on percent current shaft to 100% on the scale. Install cover to module, remove end cap from percent current knob, loosen knob/shaft screw and align the knob indicator line with 100% on the module cover.

TEMPERATURE CALIBRATION

The control module has been factory calibrated and normally requires no field calibration. If field calibration becomes necessary or a calibration check is desired, remove the cover and proceed as follows:

1. Place AUTO/MAN switch in MAN position.
2. Operate chiller loading and unloading manually until the temperature of the leaving chilled water is steady at the desired control point (for example, 45°F) using a reliable thermometer.
3. Switch the AUTO/MAN switch to AUTO position and quickly position the TEMPERATURE knob to a position where both the LOAD and UNLOAD lights are off. A voltmeter between terminals IO1 and COM on the upper terminal strip of the module should read 7.5 volts d.c. In this mode the adjustable temperature control pot is set at the actual chilled water temperature.
4. Check the pointer on the shaft against the temperature scale. It should read the same as the water temperature; if not, rotate the pointer to the proper setting without disturbing the shaft position.
5. Install cover on module and check knob position; the mark should line up with the water temperature. If adjustment is necessary, remove end cap from temperature knob, loosen knob/shaft screw and make proper scale alignment.

RAMP-UP CALIBRATION

The ramp-up functions to control the loading of the compressor at startup and is initiated automatically each time the compressor starts. Ramp-up ends when the selected time expires or when the chilled water temperature reaches the controller setpoint.

A maximum ramp-up time of 45 minutes is achieved by setting the START POINT at 0% LOAD and the RAMP TIME at MAX. Both settings are made on the two dashpots so marked on the right side of the module. (See Figure 5).

Any combination may be set to control the loading rate to suit the system requirements. Obviously a START PT setting of 100% effectively voids the ramp function.

It should be remembered that the ramp-up feature controls the compressor loading by temporarily resetting the current limit. This override action can be observed during Ramp-Up control by the alternate lighting of the amber current limit signal and the green load signal.

Actual ramp-up time with the chilled water temperature above the control point is determined by the formula:

$$\text{Ramp-up Time (min.)} = \frac{\% \text{ Current} - \% \text{ Start Point}}{45} \times \text{Ramp Time Setting}$$

Example:

$$\text{Ramp Time} = 0.75 \quad \text{Start Point} = 30\% \\ \% \text{ Current} = 100\%$$

$$\text{Ramp Time} = (1.00 - 0.30) \times 45 \times 0.75 = 24 \text{ minutes}$$

PULSE RATE CALIBRATION

The pulse rate (rate of corrective action) is applied to control the loading rate. When the leaving chilled water temperature differs from the control point by $\pm 5^\circ\text{F}$, the vanes must be repositioned at the slowest rate that will maintain stable control.

The pulse rate setting depends on the volume of chilled water in the piping loop. The pulse rate is adjustable from 2 (DEC.) to 25 (INC.) pulse per minute. A system with a small volume can be set at a fast rate and conversely slower for large systems.

The pulse rate can be set by making an adjustment to the blue PULSE RATE pot and counting the rate per minute that the red or green lights come on when the chilled water temperature is near the control point. Adjust the pot counterclockwise to increase pulse rate; clockwise to reduce rate.

CURRENT TRANSFORMER

The current transformer located in the motor starter is used to generate an A.C. voltage signal which varies directly with the compressor motor current.

This signal is calibrated at the factory or by the McQuay Service technician performing the initial startup of the chiller. This signal normally is adjusted to approximately 5 volts a.c. corresponding to the Rated Load Ampere (RLA) on the compressor nameplate.

The signal is continuously monitored by the control module to prevent the motor current from exceeding the full load amperes.

Calibration of this signal, although not complex, can be hazardous with improper procedures. Therefore, if calibration is needed, it is recommended that the McQuay Service technician be called to perform the work.

VANE SPEED ADJUSTMENT

The vane speed at which the capacity control vanes open or close is controlled by the rate of oil bleed-off from the vane actuating piston. This bleed-off rate is adjustable by positioning the needle valves on SA and SB solenoid valves located in-the lube box.

Screwdriver openings in the left side of the lube box permit access. The upper opening accesses the SB needle valve for adjusting the vane OPENING speed for loading the compressor (Refer to Figure 6). Turn this screw clockwise to decrease the vane opening speed and counterclockwise to

increase the opening speed.

The lower opening accesses the SA needle valve for adjusting the CLOSING speed for unloading the compressor. The same adjustment applies clockwise to decrease closing, counterclockwise to increase vane closing.

The vanes are factory set so that from fully closed to fully open positioning of the vanes requires about 3 minutes and about 1 minute from fully open to fully closed. (Exception: CE126 settings are 9 minutes to open and 3 minutes to close).

LOAD RECYCLING THERMOSTAT SETTING

During the initial startup procedure the McQuay Service technician will set the LRT to control the compressor on and off line at the proper temperature.

Normally this control should stop the compressor when the leaving chilled water drops about 3°F below the control point, but in no case lower than 38°F. For example, if the control module is set to control at 45°, the LRT should stop the compressor at 42°F. The LRT has a non-adjustable differential of $2\frac{1}{2}^{\circ}\text{F} \pm 1$; therefore, in the example above, compressor starting would occur at 42°+ differential.

Since the LRT scale is not highly accurate, a practical setting can be made with the machine running. Turn the dial

clockwise (to a higher temperature) until the compressor stops. At this point compare the actual water temperature with the dial setting. If they agree, then reset to the proper cutout setting (3° below control point). If they differ, note the difference and direction and make the setting accordingly.

LOW OIL TEMPERATURE THERMOSTAT

It is important to understand that this thermostat simply prevents the compressor from starting with cold oil and has no function after the compressor is started. It is shunted out at the end of the prelube cycle.

Therefore, the setting needs to be as high as practical without causing a nuisance. It is normally set about 40°F above the normal high ambient temperature in the equipment room. The operator making a setting of the LOT should, however, consider the range of ambient temperature.

Checking the LOT calibration can be accomplished by adjusting the control with the compressor off. Adjust dial clockwise (to higher temperature) until LOT switch clicks and then compare the actual oil temperature with the dial reading. If they differ, note the difference and make setting accordingly.

FIGURE 13. TROUBLESHOOTING GUIDE – CURRENT CONTROL PANEL







<p>ALL LIGHTS OUT</p> 	<ol style="list-style-type: none"> 1. On/Off switch. 2. Disconnect or breaker open 3. Control circuit fuse blown. 	<ol style="list-style-type: none"> 1. Switch position. 2. Check breaker or disconnect. 3. Fuse size, check for ground or control circuit short 	<ol style="list-style-type: none"> 1. Turn on. 2. Close. 3. Replace fuse with correct size, repair grounded item or replace shorted component.
<p>MOTOR TEMPERATURE</p> 	<ol style="list-style-type: none"> 1. Motor starter problem. 2. Loss of refrigerant. 3. Motor cooling feed problem 4. Low voltage. 5. Single phasing 6. Faulty R1 relay. 7. Faulty Guardrstor diode. 8. Open thermstor. 9. Faulty Guardrstor relay. 10. Unbalanced voltage. 	<ol style="list-style-type: none"> 1. Measure motor winding resistance. 2. Leak test, check charge 3. Filter-drier plugged 4. Measure supply voltage; include wire size voltage drop. 5. Motor fuses, incoming power lines. 6. Relay action. 7. Check diode 8 Thermistor resistance. 9. Interchange Surgegard and Guardrstor relays. 10. Measure phase voltages, 	<ol style="list-style-type: none"> 1. Contact McQuay Service. 2. Repair leak, add refrigerant. 3. Replace core or drier. 4. Increase supply voltage, replace wire, tighten lugs. 5. Replace fuse, check operation, check power company. 6. Replace. 7. Replace diode. 8. Contact McQuay Service 9. Replace defective relay. 10. Tighten electrical connections.
<p>OIL PRESSURE</p> 	<ol style="list-style-type: none"> 1. Vane closed switch not closed. 2. Vane closed switch defective. 3. Oil pump Failure 4. Faulty R2 relay. 5. OTD relay malfunction. 6. Oil line valves closed. 7. Oil filter plugged. 8. Oil cooler malfunction. 9. Low oil pressure 10. Faulty oil differential switch 	<ol style="list-style-type: none"> 1. Vane closing speed 2. Switch contacts. 3. Oil pump. 4. Relay action. 5. Relay action. 6. Valve positron 7. Oil pressure drop. 8. Feed oil lines for temperature. 9a. Pump. b. Relief valve. c. Filter. d. Bearings and seals. 10. Opening, closing pressure. 	<ol style="list-style-type: none"> 1. Adjust vane close speed 2. Replace. 3. Repair or replace. 4. Replace. 5. Repair or replace. 6. Open valves. 7 Change filter. 8 Adjust coolant flow. 9a. Repair, replace b. Reset. c. Change filter. d. Contact McQuay Service. 10. Replace.
<p>OIL TEMPERATURE</p> 	<ol style="list-style-type: none"> 1. Faulty oil cooler solenoid. 2. Plugged oil cooler water strainer. 3. Service valve partially closed. 4. Low refrigerant charge. 5. High coolant temperature 6. Plugged refrigerant filter-drier. 7. Oil heater. 8. Faulty switch. 9. Loosely mounted bulb. 10. Leaking oil cooler solenoid. 11. Switch setting wrong. 	<ol style="list-style-type: none"> 1. Check solenoid valve and coil. 2. If water cooled, check strainer. 3. Check valve positron. 4. Check for leaks. 5. Check refrigerant flow, or if water cooled, water temperature. 6. Check pressure drop 7. Check for faulty heater 8. Switching action. 9. Bulb mounting. 10. Check solenoid closing 11. Check switch setting. 	<ol style="list-style-type: none"> 1. Replace coil and/or valve. 2. Clean or replace strainer. 3. Open valves. 4. Fix leak and charge unit. 5. If water cooled lower water temperature or increase water flow. 6. Replace filter-drier. 7 If faulty, replace. 8. Replace faulty switch. 9. Make good bulb contact. 10. Repair or replace. 11. Adjust switch.
<p>LOW PRESSURE</p> 	<ol style="list-style-type: none"> 1. Loss of refrigerant. 2. Restricted refrigerant flow. 3. Expansion valve malfunction. 4. Faulty liquid solenoid valve. 5. Fault pumpdown switch. 6. Compressor not unloading. 7. Low condenser water temperature 8. Restricted evaporator water flow. 9. Excessive oil in system. 	<ol style="list-style-type: none"> 1. Compressor suction superheat. 2. Check for unusual pressure drop. 3. Manually operate valve 4. Liquid valve. 5. Check switch action 6a. Control module. b. Open sensor. c. Vane damage. 7. Cooling tower control. 8. Measure flow. 9. Oil level. 	<ol style="list-style-type: none"> 1. Adjust refrigerant charge 2. Remove restriction. 3. Adjust, repair, replace. 4. Repair, replace. 5. Repair, replace. 6a. Calibrate. b. Replace. c. Repair. 7. Adjust control. 8. Adjust. 9. Adjust oil charge.

FIGURE 13 Continued. TROUBLESHOOTING GUIDE

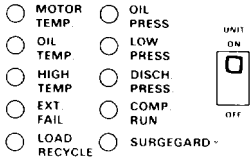
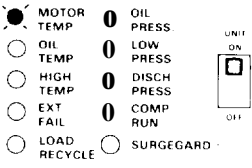
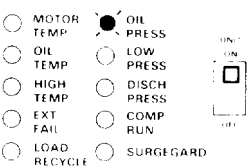
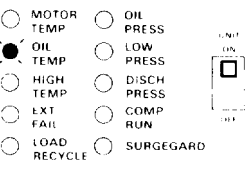
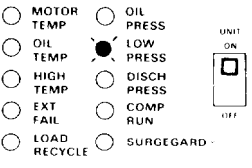
SYMPTOM	POSSIBLE CAUSE	CHECK	CORRECTIVE ACTION
DISCHARGE TEMPERATURE 	<ol style="list-style-type: none"> 1. Low refrigerant charge. 2. Low refrigerant flow. 3. Condenser water flow too low. 4. Condenser water temperature too high. 5. High suction superheat. 	<ol style="list-style-type: none"> 1. Check charge. 2. Check superheat. 3. Check water strainer and valve positions. 4. Examine cooling tower 5. Faulty expansion valve(s). 	<ol style="list-style-type: none"> 1. Adjust as required. 2. Adjust expansion valve 3. Clean strainer is dirty, open valves if partially closed. 4. Adjust tower control as required. 5. Repair or replace.
DISCHARGE PRESSURE 	<ol style="list-style-type: none"> 1. Cooling tower problem. 2. Low condenser water flow. 3. Fouled, dirty tubes. 4. Refrigerant overcharge. 5. Warm chilled water (startup). 6. Air in refrigerant system. 	<ol style="list-style-type: none"> 1a. Check tower water bypass. b. Check tower operation. 2. Pump, strainer 3. Measure condenser water pressure drop 4. Check subcooling. 5. Water temperature. 6. Overall temperature and pressures 	<ol style="list-style-type: none"> 1a. Adjust or replace control b. Clean or repair, 2. Repair, clean. 3. Clean tubes. 4. Adjust refrigerant charge. 5. Regulate flow to depress temperature. 6. Purge air.
EXTERNAL FAILURE 	<ol style="list-style-type: none"> 1. Power interruption (restored) or voltage dip. 2. Low water flow. 3. No water flow 4. Defective R7 relay. 5. Flow switch open. 6. Pump interlocks open. 7. Compressor starter 8. Power single phase. 	<ol style="list-style-type: none"> 1. Relays R1 R2, R5, R7 will be de-energized and open. 2a. Check water valves. b. Flow switch malfunction. c. Water strainer dirty. d. Fouled tubes 3a. Pumps. b. Valve position c. Pump starters d. Condenser pump relay. 4. Check relay operation 5. Circuit continuity. 6. Circuit continuity. 7a. Overloads tripped b. Incomplete transition. 8a. Compressor motor. b. MCR failure 	<ol style="list-style-type: none"> 1. Push reset button 2a. Properly position valves. b. Repair flow switch. c. Clean strainer d. Clean tubes. 3a. Repair or restart. b. Open valves. c. Reset OL; repair interlocks d. Repair, replace. 4. Replace relay. 5. Correct switch action. 6. Repair, replace. 7a. Reset or recalibrate. b. Reset or repair starter 8a. Call McQuay Service. b. Repair or replace.
COMPRESSOR NOT RUNNING 	<ol style="list-style-type: none"> 1. The compressor starter has been energized but the compressor does not start. This symptom will remain for 60 seconds at which time the control circuit will switch off and the external failure light will go on. 	<ol style="list-style-type: none"> 1a. Starter and MCR relays b. Disconnect or circuit breaker open. c. O.L tripped 	<ol style="list-style-type: none"> 1 a. Repair as required. b. Close switch or circuit breaker. c. Reset
LOAD RECYCLE 	<ol style="list-style-type: none"> 1. Normal shutdown 2. Load recycle thermostat. 3. Anti recycle thermostat. 4. Low source water temperature (Templifier). 	<ol style="list-style-type: none"> 1. Chilled water temperature satisfied. 2a. Setting drift b. Loss of bulb charge. 3a. Time delay not yet timed out b. Too fast response to load changes. 4. Source water temperature. 	<ol style="list-style-type: none"> 1. None required. 2a. Recalibrate control. b. Replace LRT. 3a. Wait for 20 minutes off time delay. b. Adjust controls. 4. Check heat source
SURGE GARD 	<ol style="list-style-type: none"> 1. Dirty condenser. 2. High pressure lift 3. Refrigerant overcharge 4. Defective R5 relay 5. Low condenser water flow 6. Open thermistor circuit. 7. Cooling tower. 8. Faulty Surgegard relay 	<ol style="list-style-type: none"> 1. Condenser tubes 2. Water temperatures. 3. Discharge pressure 4. Relay action 5. Strainer, valves 6. Check circuit 7. Water level 8. Interchange Guardistor Surgegard relays 	<ol style="list-style-type: none"> 1. Clean. 2. Reduce difference between entering/leaving water temperatures. 3. Reduce refrigerant charge. 4. Replace. 5. Clean strainer, open valves 6. Correct. 7. Adjust makeup control. 8. Replace fault relay.

FIGURE 13 Continued. TROUBLESHOOTING GUIDE

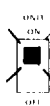
<p>COMPRESSOR STARTER OVERLOAD TRIPPED</p> <p> <input type="radio"/> MOTOR TEMP <input type="radio"/> OIL TEMP <input type="radio"/> HIGH TEMP <input checked="" type="radio"/> EXT FAIL <input type="radio"/> LOAD RECYCLE </p> <p> <input type="radio"/> OIL PRESS <input type="radio"/> LOW PRESS <input type="radio"/> DISCH PRESS <input type="radio"/> COMP RUN <input type="radio"/> SURGEGARD </p> 	<ol style="list-style-type: none"> 1. Motor circuit problem. 2. Overload relay calibration. 3. Current limit set too high in control module. 4. Faulty current transformer (C.T.). 5. Single phase. 	<ol style="list-style-type: none"> 1. Check continuity. 2. Setting, dashpot oil level. 3a. Check resistor setting a b. Check module setting 4. Secondary output 5. Fuses 	<ol style="list-style-type: none"> 1. Contact McQuay Service. 2. Reset, add dashpot oil. 3a. Reset. b. Recalibrate control module. 4. Replace. 5. Correct fault.
<p>HUNTING</p> <p> <input type="radio"/> MOTOR TEMP <input type="radio"/> OIL TEMP <input type="radio"/> HIGH TEMP <input checked="" type="radio"/> EXT FAIL <input type="radio"/> LOAD RECYCLE </p> <p> <input type="radio"/> OIL PRESS <input type="radio"/> LOW PRESS <input type="radio"/> DISCH PRESS <input checked="" type="radio"/> COMP RUN <input type="radio"/> SURGEGARD </p> 	<ol style="list-style-type: none"> 1 Capacity control vane speed. 2. Fast pulse rate (control module). 3 Faulty expansion valves 4. Fluctuating evaporator water flow. 5. Low refrigerant charge 6. Low condenser water temperature 	<ol style="list-style-type: none"> 1 Vane operation. 2. Measure pulse rate. 3. Observe suction pressure 4. Evaporator pressure drop 5. Superheat, subcooling 6. Measure temperature. 	<ol style="list-style-type: none"> 1. Reset vane speed needle valve 2. Adjust to slower rate. 3. Repair, replace. 4. Correct flow deficiency. 5. Adjust refrigerant charge 6. Adjust tower controls.
<p>COMPRESSOR WILL NOT LOAD</p> <p> <input type="radio"/> MOTOR TEMP <input type="radio"/> OIL TEMP <input type="radio"/> HIGH TEMP <input checked="" type="radio"/> EXT FAIL <input type="radio"/> LOAD RECYCLE </p> <p> <input type="radio"/> OIL PRESS <input type="radio"/> LOW PRESS <input type="radio"/> DISCH PRESS <input checked="" type="radio"/> COMP RUN <input type="radio"/> SURGEGARD </p> 	<ol style="list-style-type: none"> 1. Faulty control module 2. Shorted sensor circuit (chiller) 3. Open sensor circuit (Templifier). 4. Wrong module jumper connections. 5. Defective SB solenoid coil 6. Loss of CT voltage. 7. SB needle valve closed/restricted. 8. Faulty relay R4. 9. Low refrigerant charge. 10. Vane seal leakage. 11. Faulty LPO switch. 	<ol style="list-style-type: none"> 1 a. Check + 20 & + 6.2 VDC supply b. Check load action 2. Remove one sensor lead 3. Jumper COM & ISA. 4. Verify connections. 5. Solenoid action 6. Measure at 1WHT & 3B 7. Open wide. 8. Check relay 9. Superheat. IO. Mechanical action. II. Check switch junction. 	<ol style="list-style-type: none"> 1a. Replace module. b. Replace module. 2. If compressor loads, replace sensor. 3. If compressor loads, replace sensor. 4. Correct pin connections. 5. Replace. 6. Reset or replace 7. Clean and reset. 8. Replace 9. Adjust charge. 10. Call McQuay Service. 11. Replace.
<p>COMPRESSOR WILL NOT UNLOAD</p> <p> <input type="radio"/> MOTOR TEMP <input type="radio"/> OIL TEMP <input type="radio"/> HIGH TEMP <input checked="" type="radio"/> EXT FAIL <input type="radio"/> LOAD RECYCLE </p> <p> <input type="radio"/> OIL PRESS <input type="radio"/> LOW PRESS <input type="radio"/> DISCH PRESS <input checked="" type="radio"/> COMP RUN <input type="radio"/> SURGEGARD </p> 	<ol style="list-style-type: none"> 1. Open sensor (chiller) 2 Shorted sensor circuit (Templifier). 3. Faulty control module. 4. Defective SA solenoid coil. 5. Faulty 4-way valve. 6. SA needle valve closed/restricted. 7. Vane damage 8. Wrong module jumper connection. 	<ol style="list-style-type: none"> 1 Jumper +6.2 & ISA 2 Remove one sensor lead. 3a. Check + 20 & + 6.2 VDC supply. b. Check load action 4. Check solenoid action. 5. Valve operation. 6. Open wide. 7. Mechanical action 8 Verify connections 	<ol style="list-style-type: none"> 1. If compressor unloads, replace sensor. 2 If compressor unloads, replace sensor. 3a. Replace module. b. Replace module. 4. Replace 5. Repair, replace. 6. Clean, reset. 7. Call McQuay Service. 8. Correct pin connections.
<p>CANNOT RESET CONTROL CIRCUIT</p> <p> <input type="radio"/> MOTOR TEMP <input type="radio"/> OIL TEMP <input type="radio"/> HIGH TEMP <input checked="" type="radio"/> EXT FAIL <input type="radio"/> LOAD RECYCLE </p> <p> <input type="radio"/> OIL PRESS <input type="radio"/> LOW PRESS <input type="radio"/> DISCH PRESS <input checked="" type="radio"/> COMP RUN <input type="radio"/> SURGEGARD </p> 	<ol style="list-style-type: none"> 1. Faulty relays R1 R2, R5, R7. 	<ol style="list-style-type: none"> 1. To check relays, energize control power and on/off switch to OFF. Install each relay in R7 base. EXT FAIL light should glow. P RESET button. EXT FAIL light should go out and stay out; if not, relay is faulty. 	<ol style="list-style-type: none"> 1. Replace faulty relay.

FULL LOAD DESIGN CONDITIONS

LOG SHEET

JOB NO. _____
CHILLER NO. _____
Compressor F.L.A. _____
Condenser Pump F.L.A. _____
Chiller Pump F.L.A. _____

CHILLER
GPM _____
PRESS. DROP _____
LVG. TEMP. _____
ENT. TEMP. _____
REFRIG. TEMP. _____

CONDENSER
GPM _____
PRESS. DROP _____
LVG. TEMP. _____
ENT. TEMP. _____
REFRIG. TEMP. _____

				WATER								WEEKLY SYSTEM								QUARTERLY							
DATE	TIME	TEMP.	REMARKS	1	2	3	4	5	6	7	8	9	10	11	12	13	14	15	16	17	18	19	20	21	22	23	

McQUAY SERVICE PROGRAMS

It is important that an air conditioning system receive adequate maintenance if the full equipment life and full system benefits are to be realized.

Maintenance should be an ongoing program from the time the system is initially started. A full inspection should be made after 3 to 4 weeks of normal operation on a new installation and on a regular basis thereafter.

McQuay offers a variety of maintenance services through its Nationwide Service Organization and can tailor these services to suit the needs of the building owner.

Most popular among these services is the McQuay Comprehensive Maintenance Plan wherein McQuay assumes full responsibility for your air conditioning equipment. Included are regular routine inspections and emergency service by factory trained technicians. All parts, labor, materials, and refrigerant are included in a McQuay Comprehensive Maintenance Contract.

For further information concerning the many services available, contact your local McQuay Service representative.