

Centrifugal Compressor Water Chillers

Group: Chillers

Part Number: 331374801

REV
0A

Date: **August 2012**

Models WSC,WDC,WCC,HSC

(Includes High Voltage 10/11kV WDC/WCC models)



Table of Contents

Introduction	3	Multiple Chiller Setup	34
General Description	3	Prestart System Checklist	37
Application	3	Commissioning	38
Installation	4	Standby Power	38
Receiving and Handling	4	MicroTech II™ Control	38
Location and Mounting.....	5	Capacity Control System	40
Operating/Standby Limits.....	6	Surge and Stall	42
System Water Volume	6	Lubrication System.....	42
Low Condenser Water Temperature		Hot Gas Bypass.....	44
Operation	7	Condenser Water Temperature	44
Water Piping	9	Maintenance	45
Field Insulation Guide	13	Pressure/Temperature Chart.....	45
Physical Data and Weights.....	15	Routine Maintenance	45
Complete Unit Physical Data.....	17	Annual Shutdown	49
Oil Coolers.....	19	Annual Startup	49
Oil Heater	22	Repair of System.....	50
Relief Valves	22	Oil Analysis	51
Electrical	23	Maintenance Schedule	54
Power Wiring.....	23	Long Term Storage	56
Installation Instructions for 10/11kV Motor		Service Programs	57
Units	25	Operator Schools	57
Full Metering Option	29	Warranty Statement.....	57
Control Power Wiring Options	29		
Field Wiring, Controls & Starters	31		

Hazard Identification

⚠ DANGER

Dangers indicate a hazardous situation which will result in death or serious injury if not avoided.

⚠ WARNING

Warnings indicate potentially hazardous situations, which can result in property damage, severe personal injury, or death if not avoided.

⚠ CAUTION

Cautions indicate potentially hazardous situations, which can result in personal injury or equipment damage if not avoided.

Document:	IM 1044-2
Issue Date:	September 2009
Revision Date:	August 2012
Replaces:	June 2012

©2012 Daikin. Illustrations and data cover the Daikin product at the time of publication and we reserve the right to make changes in design and construction at anytime without notice.

™® The following are trademarks or registered trademarks of their respective companies: BACnet from ASHRAE; LONMARK, LonTalk, LONWORKS, and the LONMARK logo are managed, granted and used by LONMARK International under a license granted by Echelon Corporation; ElectroFin from AST ElectroFin Inc.; Modbus from Schneider Electric; MicroTech II, Open Choices from Daikin; Loctite from Henkel Company; 3M, Scotchfil and Scotchkote from the 3M Company; Victaulic from Victaulic Company; Megger from Megger Group Limited.

Introduction

General Description

Daikin Centrifugal Water Chillers are complete, self-contained, automatically controlled fluid chilling units. Each unit is completely assembled and factory tested before shipment. Models WSC/WDC/WCC are cooling-only and Models HSC are cooling with heat recovery accomplished in a bundle of condenser tubes separate from the cooling tower tube bundle.

In the WSC and HSC series, each unit has one compressor connected to a condenser and evaporator. The WDC series is equipped with two compressors operating in parallel on a single evaporator and condenser. The WCC series is equipped with two compressors, each operating on one refrigerant circuit of a two circuit evaporator and condenser. Information in this manual referring to WSC and WDC also applies to WCC and HSC units except where specifically noted.

The chillers use refrigerant R-134a to reduce the size and weight of the package compared to negative pressure refrigerants, and since R-134a operates at a positive pressure over the entire operation range, no purge system is required. The controls are pre-wired, adjusted and tested. Only normal field connections such as piping, electrical and interlocks, etc. are required, thereby simplifying installation and increasing reliability. Most necessary equipment protection and operating controls are factory installed in the control panel.

The basic sizes of units are the 063, 076, 079, 087, 100, 113 and 126. They provide a cooling capacity range from 200 to 2700 tons. In this manual all references to the WSC models will equally apply to other models unless specifically referenced otherwise.

High Voltage Models

Certain 100, 113, and 126 size WDC and WCC units are available in high-voltage (10/11kV). These models will have different dimensions, weights, and installation details than the standard low/medium voltage models. See your Certified Dimension Drawing for details specific to your unit. See page 25 for the procedure to mount the terminal box on 10/11 kV units.

Application

The procedures presented in this manual apply to the standard WSC/WDC/WCC family of chillers and HSC heat recovery chillers. Refer to the Operating Manual, OM CentrifMicro-II for details of operation of the MicroTech II™ unit controller (latest version available on www.DaikinApplied.com).

All Daikin centrifugal chillers are factory tested prior to shipment and must be initially started at the job site by a factory trained Daikin service technician. Failure to follow this startup procedure can affect the equipment warranty. The standard limited warranty on this equipment covers parts that prove defective in material or workmanship. Specific details of this warranty can be found in the warranty statement furnished with the equipment.

Cooling towers used with Daikin centrifugal chillers are normally selected for maximum condenser inlet water temperatures between 75°F and 90°F (24°C and 32°C). Lower entering water temperatures are desirable from the standpoint of energy reduction, but a minimum does exist. For recommendations on optimum entering water temperature and cooling tower fan control, consult Daikin catalog *CAT 605*, Applications Section, available on www.DaikinApplied.com. Heat recovery models, HSC, basically operate the same as cooling-only units. The heat recovery function is controlled externally to the chiller as explained later in this manual.

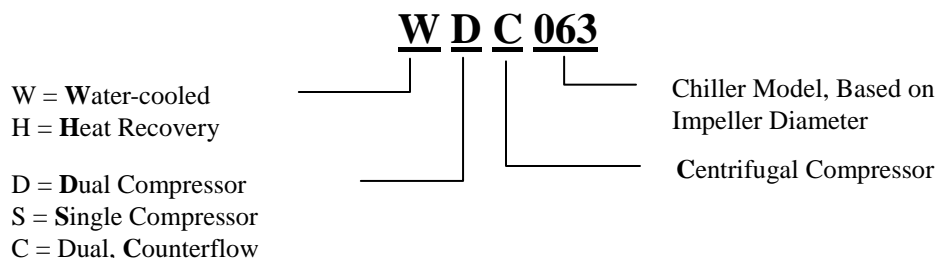

Installation

Receiving and Handling

The unit should be inspected immediately after receipt for possible damage.

All Daikin centrifugal water chillers are shipped FOB factory and all claims for handling and shipping damage are the responsibility of the consignee.

Insulation corners from the evaporator's rigging hole locations are shipped loose and should be glued in place after the unit is finally placed. Neoprene vibration pads are also shipped loose. Check that these items have been delivered with the unit.

If so equipped, leave the shipping skid in place until the unit is in its final position. This will aid in handling the equipment.

Extreme care must be used when rigging the equipment to prevent damage to the control panels or refrigerant piping. See the certified dimension drawings included in the job submittal for the center of gravity of the unit. Consult the local Daikin sales office for assistance if the drawings are not available.

The unit can be lifted by fastening rigging hooks to the outermost four rigging eyes (see Figure 1). Spreader bars must be used between the rigging lines to prevent damage to the control panels, piping and motor terminal boxes.

Figure 1, WSC Major Component Locations

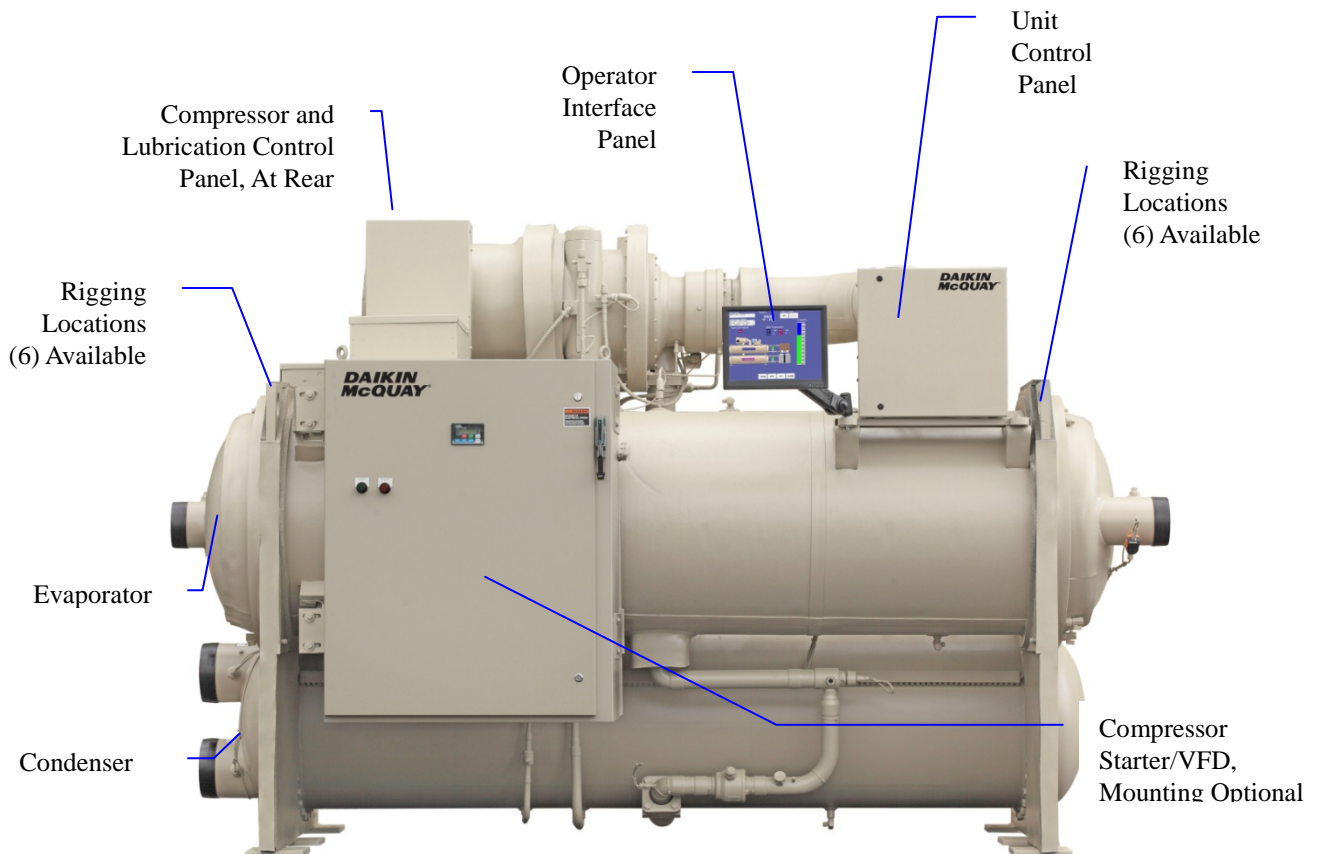
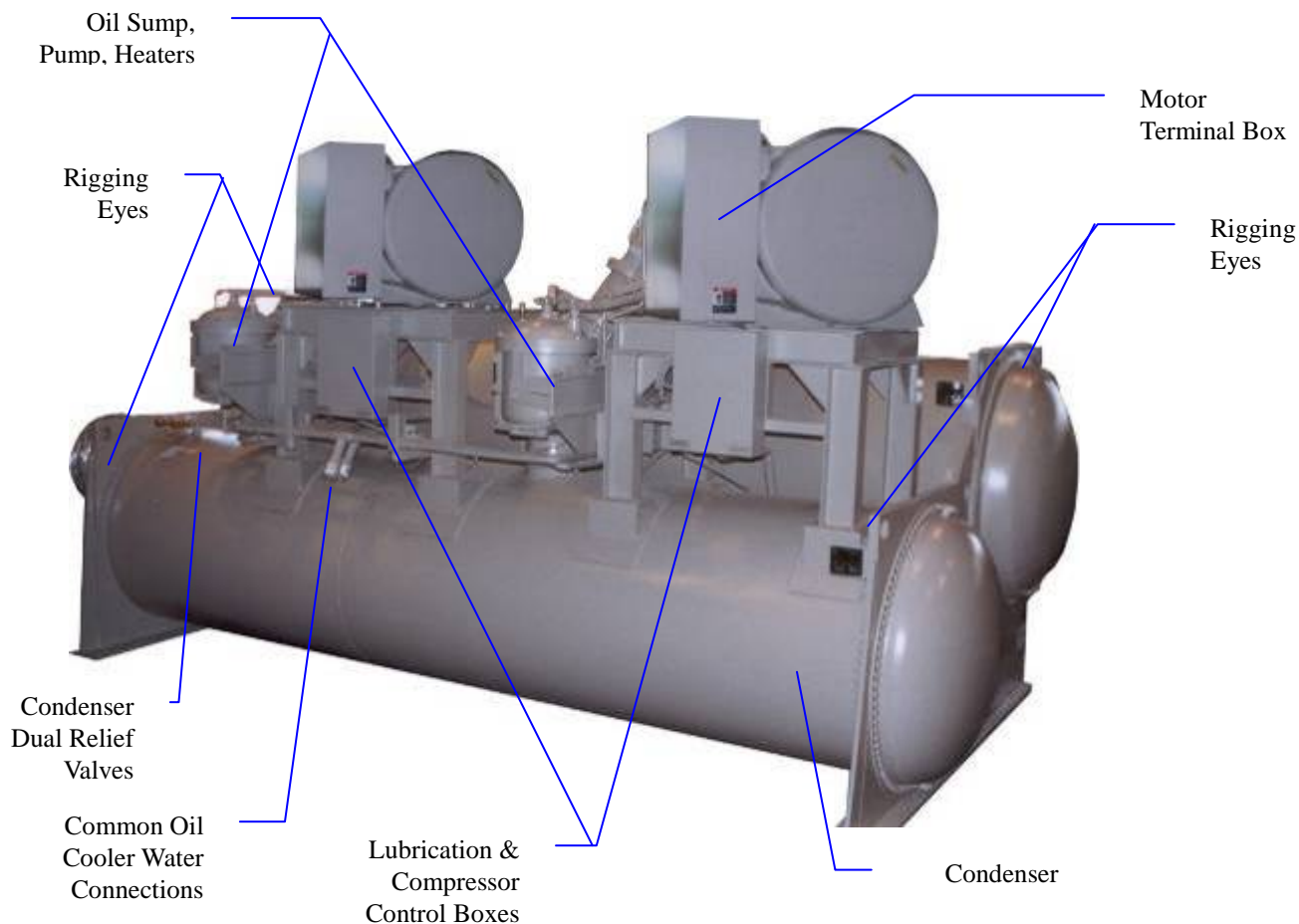

Figure 2, WDC Major Component Location



Notes:

1. Chilled water and condenser connection location can vary. Check markings on unit or consult unit certified drawings for connection locations on specific units.
2. WCC two-circuit units have separate evaporator and condenser relief valves on each circuit.

Location and Mounting

The unit must be mounted on a level concrete or steel base and must be located to provide service clearance at one end of the unit for possible removal of evaporator tubes and/or condenser tubes. Evaporator and condenser tubes are rolled into the tube sheets to permit replacement if necessary. The length of the vessel should be allowed at one end. Doors or removable wall sections can be utilized for tube clearance. Minimum clearance at all other points, including the top, is 3 feet (1 meter). The National Electric Code (NEC) can require four feet or more clearance in and around electrical components and must be checked.

The chillers are designed for indoor installation only. Special procedures must be executed to prevent damage if freezing indoor temperatures are possible.

Operating/Standby Limits

Equipment room operating temperature:	40°-104°F (4.4°-40°C)
Equipment room temperature, standby, with water in vessels and oil cooler:	40°-104°F (4.4°-40°C)
Equipment room temperature, standby, without water in vessels and oil cooler:	0°F-122F (-18°C-50°C)
Maximum entering condenser water temperature, startup:	design + 5°F (2.7°C)
Maximum entering condenser water temperature, operating:	job-specific design temperature
Minimum entering condenser water temperature, operating:	see following page.
Minimum leaving chilled water temperature:	38°F (3.3°C)
Minimum leaving chilled fluid temperature with correct anti-freeze fluid:	15°F (9.4°C)
Maximum entering chilled water temperature, operating:	90°F (32.2°C)
Maximum oil cooler or VFD entering temperature:	80°F (26.7°C)
Minimum oil cooler/VFD entering temperature:	42°F (5.6°C)

Vibration Pads

The shipped-loose neoprene vibration pads should be located under the corners of the unit (unless the job specifications state otherwise). They are installed to be flush with the sides and outside edge of the feet. Most WSC units have six mounting feet although only the outer four are required. Six pads are shipped and the installer can place pads under the middle feet if desired.

Mounting

Make sure that the floor or structural support is adequate to support the full operating weight of the complete unit. It is not necessary to bolt the unit to the mounting slab or framework; but should this be desirable, 1 1/8" (28.5 mm) mounting holes are provided in the unit support at the four corners.

Note: Units are shipped with refrigerant and oil valves closed to isolate these fluids for shipment. Valves must remain closed until start-up by the Daikin technician.

Nameplates

There are several identification nameplates on the chiller:

- The unit nameplate is located on the side of the Unit Control Panel. It has a Style No. XXXX and Serial No. XXXX. Both are unique to the unit and will identify it. These numbers should be used to identify the unit for service, parts, or warranty questions. This plate also lists the unit refrigerant charge.
- Vessel nameplates are located on the evaporator and condenser. Along with other information, they have a National Board Number (NB) and serial number, either of which identify the vessel (but not the entire unit).
- A compressor nameplate is located on the compressor itself and contains identification numbers.

System Water Volume

All chilled water systems need adequate time to recognize a load change, respond to that load change and stabilize, without undesirable short cycling of the compressors or loss of control. In air conditioning systems, the potential for short cycling usually exists when the building load falls below the minimum chiller plant capacity or on close-coupled systems with very small water volumes.

Some of the things the designer should consider when looking at water volume are the minimum cooling load, the minimum chiller plant capacity during the low load period and the desired cycle time for the compressors.

Assuming that there are no sudden load changes and that the chiller plant has reasonable turndown, a rule of thumb of “gallons of water volume equal to two to three times the chilled water gpm flow rate” is often used. A properly designed storage tank should be added if the system components do not provide sufficient water volume.

Low Condenser Water Temperature Operation

When the ambient wet bulb temperature is lower than design, the condenser water temperature can be allowed to fall. Lower temperatures will improve chiller performance.

Up to 600 Tons

Daikin centrifugal chillers up to 600 Tons are equipped with electronic expansion valves (EXV) and will start and run with entering condenser water temperatures as low as shown in Figure 3 or as calculated from the following equation on which the curves are based.

Figure 3, Minimum Entering Condenser Water Temperature (EXV)

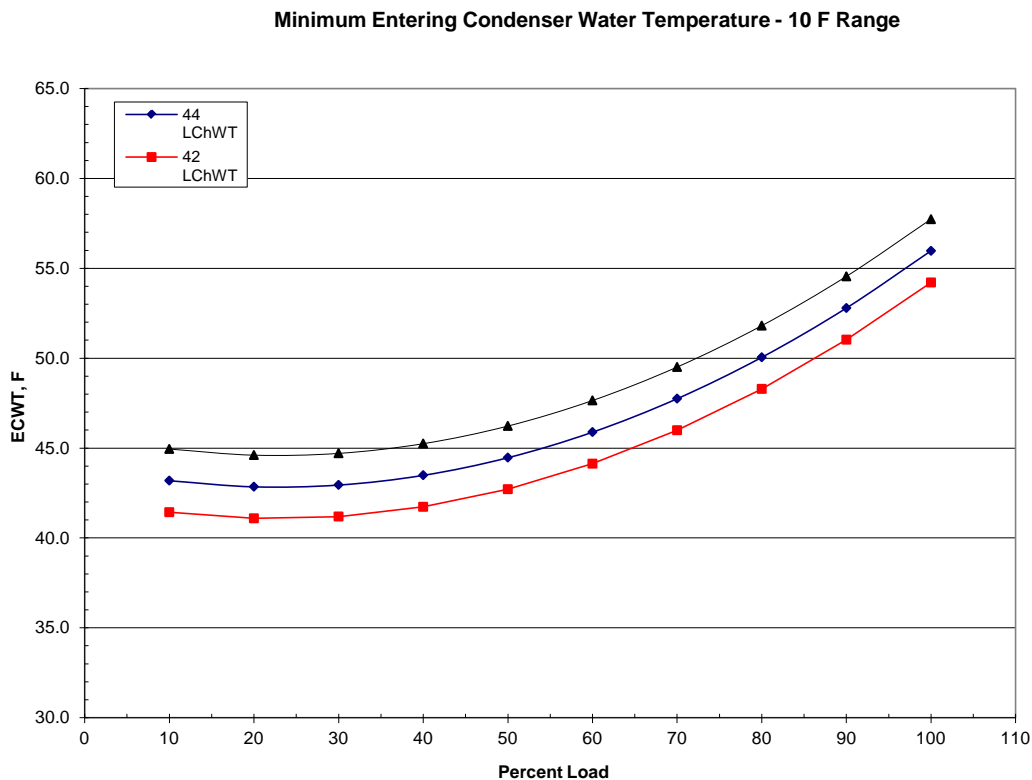

$$\text{Min. ECWT} = 5.25 + 0.88 * (\text{LWT}) - \text{DT}_{\text{FL}} * (\text{PLD}/100) + 22 * (\text{PLD}/100)^2$$

- ECWT = Entering condenser water temperature
- LWT = Leaving chilled water temperature
- DT_{FL} = Chilled Water Delta-T at full load
- PLD = The percent chiller load point to be checked

For example; at 44°F LWT, 10 degree F Delta-T, and 50% full load operation, the entering condenser water temperature could be as low as 44.5°F. This provides excellent operation with water-side economizer systems.

Over 600 Tons

Chillers over 600 Tons are equipped with thermal expansion valves (TXV) and will start and run with entering condenser water temperatures as low as calculated by the following equation and shown in the chart following.

$$\text{Min. ECWT} = 7.25 + \text{LWT} - 1.25 * \text{DT}_{\text{FL}} (\text{PLD}/100) + 22 * (\text{PLD}/100)^2$$

- ECWT = Entering condenser water temperature
- LWT = Leaving chilled water temperature
- DT_{FL} = Chilled Water Delta-T at full load
- PLD = The percent chiller load point to be checked

Figure 4, Minimum Entering Condenser Water Temperature (TXV)

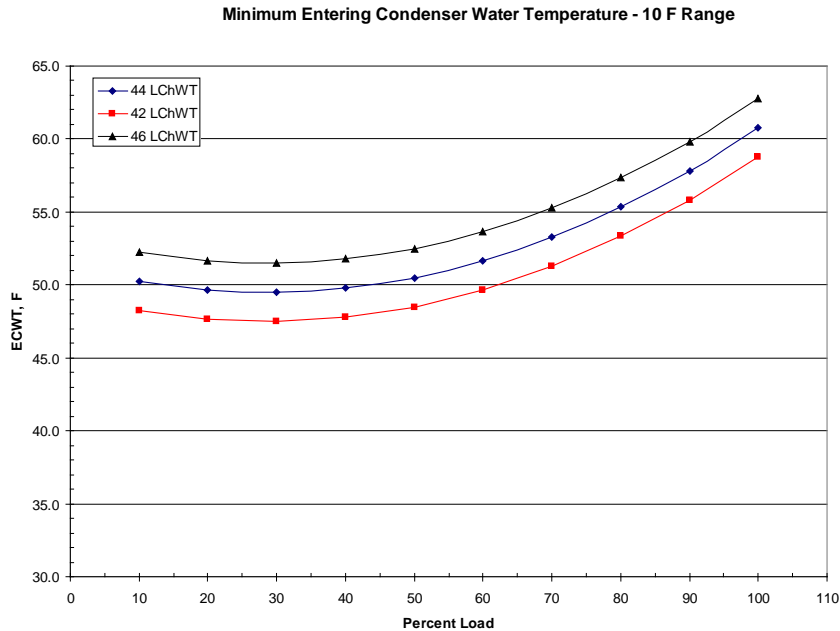

For example; at 44°F LWT, 10 degree F Delta-T, and 50% full load operation, the entering condenser water temperature could be as low as 50.5°F. This provides excellent operation with water-side economizer systems. Depending on local climatic conditions, using the lowest possible entering condenser water temperature may be more costly in total system power consumed than the expected savings in chiller power would suggest, due to the excessive fan power required.

Cooling tower fans must continue to operate at 100% capacity at low wet bulb temperatures. As chillers are selected for lower kW per ton, the cooling tower fan motor power becomes a higher percentage of the total peak load chiller power. Daikin's Energy Analyzer program can optimize the chiller/tower operation for specific buildings in specific locales.

Even with tower fan control, some form of water flow control, such as tower bypass, is recommended.

Figure 5 illustrates two temperature actuated tower bypass arrangements. The "Cold Weather" scheme provides better startup under cold ambient air temperature conditions. The check valve may be required to prevent entraining air at the pump inlet.

Figure 5, Bypass, Mild Weather Operation

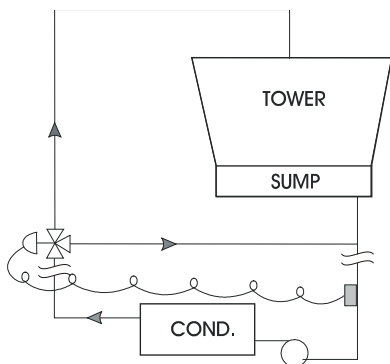

Bypass, Cold Weather Operation

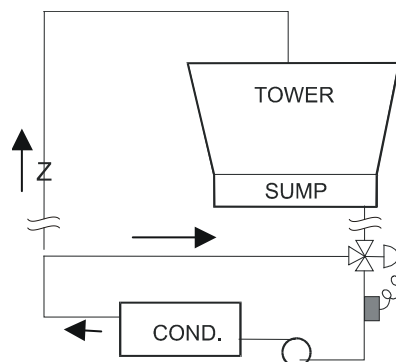

Water Piping

Water Pumps

Avoid the use of 3600/3000-rpm (two-pole motor) pump motors. It is not uncommon to find that these pumps operate with objectionable noise and vibration.

It is also possible to build up a frequency beat due to the slight difference in the operating rpm of the pump motor and the Daikin centrifugal motor. Daikin encourages the use of 1750/1460 rpm (four-pole) pump motors.

Vessel Drains at Start-up

Unit vessels are drained of water in the factory and are shipped with the drain plugs in the heads removed and stored in the control panel or with open ball valves in the drain hole. Be sure to replace plugs or close the valves prior to filling the vessel with fluid.

Evaporator and Condenser Water Piping

All evaporators and condensers come standard with Victaulic AWWA C-606 groove nozzles (also suitable for welding), or optional flange connections. The installing contractor must provide matching mechanical connections or transitions of the size and type required.

Victaulic connections are AWWA C-606 on 14-inch and larger sizes. Field supply transitions if Victaulic brand AGS® (Advanced Groove System) type grooves are used on the field piping. **Note:** Do not use PVC piping.

The tower connections on heat recovery units are always the inboard pair of connections. In the figure to the right, the condenser connections are “left-hand” when viewed from the front of the unit (Unit Control Panel and Interface Panel side), so in this case, the right-hand condenser connections would be for the tower. If the condenser connections were on the other end (“right-hand”), the tower connections would be the left-hand pair of connections.



Note: Certain WSC units with a 2-pass configuration and copper tubing may have an “over/under” connection configuration on the evaporator, rather than the side-by-side configuration shown here. Consult Certified Drawings for exact configuration and dimensions.

Important Note on Welding

If welding is to be performed on the mechanical or flange connections, remove the solid-state temperature sensor and thermostat bulbs from the wells to prevent damage to those components. Also properly ground the unit or severe damage to the MicroTech II unit controller can occur.

Note: ASME certification will be revoked if welding is performed on a vessel shell or tube sheet.

Water pressure gauge connection taps and gauges must be provided in the field piping at the inlet and outlet connections of both vessels for measuring the water pressure drops. The pressure drops and flow rates for the various evaporators and condensers are job specific and the original job documentation can be consulted for this information. Refer to the nameplate on the vessel shell for identification.

Be sure that water inlet and outlet connections match certified drawings and stenciled nozzle markings. The condenser is connected with the coolest water entering at the bottom to maximize subcooling.

CAUTION

When common piping is used for both heating and cooling modes, care must be taken to provide that water flowing through the evaporator cannot exceed 110°F which can cause the relief valve to discharge refrigerant or damage controls.

The piping must be supported to eliminate weight and strain on the fittings and connections. Piping must also be adequately insulated. A cleanable perforated basket strainer with 0.125-in perforations and 40 % open area must be installed in the evaporator water inlet line. Sufficient shutoff valves must be installed to permit draining the water from the evaporator or condenser without draining the complete system.

Victaulic Couplings

Use the following steps when installing Victaulic couplings:

1. Check for smooth pipe between the pipe end and the groove. Remove any indentations, projections, or weld seams. Failure to do this can result in a leaking joint.
2. Apply a thin coat of Victaulic or silicon lubricant to the gasket lips and exterior.
3. Position the gasket over the pipe end without overhanging the pipe.
4. Join the pipes together and slide the gasket into position, centering it between the grooves.
5. Install the housing halves over the gasket, check that the housing's keys engage the grooves on both pipes.
6. Install the bolts and thread the nuts on hand tight. Make sure that the oval heads of the bolts seat properly in the bolt holes.
7. Tighten the nuts evenly by alternating sides until metal to metal contact is made on the housing bolt pads. Make sure that the housing keys completely engage the pipe grooves.

Flow Switch

A water flow switch must be installed in the vessel outlet piping to signal the presence of adequate water flow to the vessels before the unit can start. They also serve to shut down the unit in the event that water flow is interrupted to guard against evaporator freeze-up or excessive discharge pressure.

Thermal dispersion flow switches are available from Daikin as a factory-mounted option. It is mounted in an evaporator and condenser water nozzle and factory wired.

A paddle type flow switch can be supplied by the owner for field mounting and wiring.

Figure 6, Flow Switch Mounting

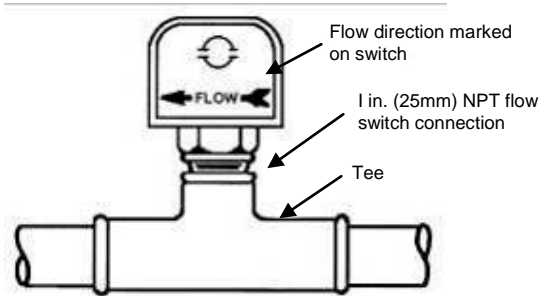

If flow switches, by themselves, are used, electrical connections in the Unit Control Panel must be made from the common T3-S terminal to terminal CF for the condenser switch and T3-S to terminal EF for the evaporator switch. See Figure 19, Field Control Wiring Diagram on page 32. The normally open contacts of the flow switch must be wired between the terminals. Flow switch contact quality must be suitable for 24 VAC, low current (16ma). Flow switch wire must be in separate conduit from any high voltage conductors (115 VAC and higher).

Table 1, Flow Switch Flow Rates

Pipe Size (NOTE)		inch	1 1/4	1 1/2	2	2 1/2	3	4	5	6	8
		mm	32 (2)	38 (2)	51	63 (3)	76	102 (4)	127 (4)	153 (4)	204 (5)
Min. Adjst.	Flow	gpm	5.8	7.5	13.7	18.0	27.5	65.0	125.0	190.0	205.0
		Lpm	1.3	1.7	3.1	4.1	6.2	14.8	28.4	43.2	46.6
	No Flow	gpm	3.7	5.0	9.5	12.5	19.0	50.0	101.0	158.0	170.0
		Lpm	0.8	1.1	2.2	2.8	4.3	11.4	22.9	35.9	38.6
Max. Adjst.	Flow	gpm	13.3	19.2	29.0	34.5	53.0	128.0	245.0	375.0	415.0
		Lpm	3.0	4.4	6.6	7.8	12.0	29.1	55.6	85.2	94.3
	No Flow	gpm	12.5	18.0	27.0	32.0	50.0	122.0	235.0	360.0	400.0
		Lpm	2.8	4.1	6.1	7.3	11.4	27.7	53.4	81.8	90.8

See notes next page.

Notes from previous page:

1. A segmented 3-inch paddle (1, 2, and 3 inches) is furnished mounted, plus a 6-inch paddle loose.
2. Flow rates for a 2-inch paddle trimmed to fit the pipe.
3. Flow rates for a 3-inch paddle trimmed to fit the pipe.
4. Flow rates for a 3-inch paddle.
5. Flow rates for a 6-inch paddle
6. There is no data for pipe sizes above 8-inch. A switch minimum setting should provide protection against no flow and close well before design flow is reached.

Alternatively, for a higher margin of protection, normally open auxiliary contacts in the pump starters can be wired in series with the flow switches as shown in Figure 19, Field Control Wiring Diagram on page 32.

⚠ CAUTION

Freeze Notice: Neither the evaporator nor the condenser is self-draining;
Both must be blown out to help avoid damage from freezing.

The piping should also include thermometers at the inlet and outlet connections and air vents at the high points.

The water heads can be interchanged (end for end) so that the water connections can be made at either end of the unit. If this is done, new head gaskets must be used and control sensors relocated.

In cases where the water pump noise can be objectionable, vibration isolation sections are recommended at both the inlet and outlet of the pump. In most cases, it will not be necessary to provide vibration eliminator sections in the condenser inlet and outlet water lines. But they can be required where noise and vibration are critical.

Cooling Towers

The condenser water flow rate must be checked to be sure that it conforms to the system design. Some form of temperature control is also required if an uncontrolled tower can supply water below about 65°F (18°C). If tower fan control is not adequate, a tower bypass valve is recommended. Unless the system and chiller unit are specifically for condenser bypass or variable condenser flow is not recommended since low condenser flow rates can cause unstable operation and excessive tube fouling.

The condenser water pumps must cycle on and off with the compressor. See Figure 19, Field Control Wiring Diagram on page 32 for wiring details.

Tower water treatment is essential for continued efficient and reliable unit operation. If not available in-house, competent water treatment specialists can be contracted.

Heat Recovery Chillers

HSC heat recovery chillers control the chilled water leaving temperature. The cooling load determines compressor loading and unloading, the same as in a conventional chiller. A heat recovery chiller's control algorithms are identical to a conventional cooling-only chiller.

The temperature of the hot water being supplied from the recovery condenser to the heating load is established by manipulating the cooling tower water temperature. The 3-way cooling tower bypass valve is controlled by the heating water inlet temperature to the recovery bundle of the condenser. Based on the signal the 3-way valve gets from the heating hot water sensor, it will bypass sufficient water around the tower to force the tower condenser water loop high enough for the recovery bundle to produce the desired hot water temperature.

The chilled water and its control system do not sense that the condensing pressure and condenser water temperatures are being regulated in this manner.

Figure 7, Heat Recovery Schematic

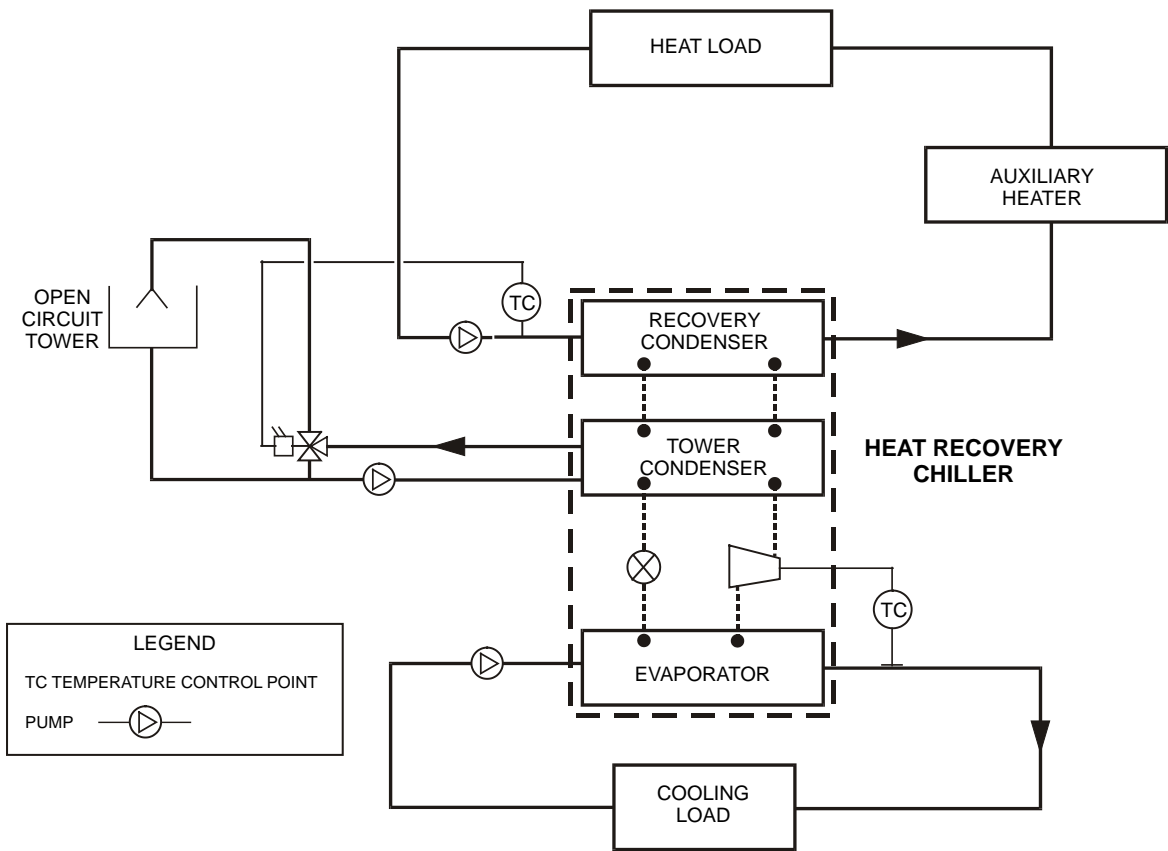

Field Insulation Guide

Figure 8, Insulation Requirements, Cooling-only Units

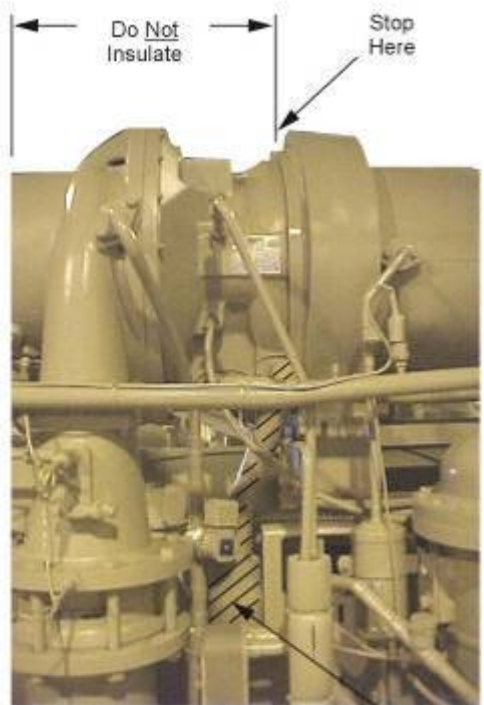

Note: Starter mounting brackets if supplied.



Expansion Valve - Insulate crosshatch area & up to the chiller insulation.

Note: Stop at motor / gearcase boundry. Do not insulate compressor!

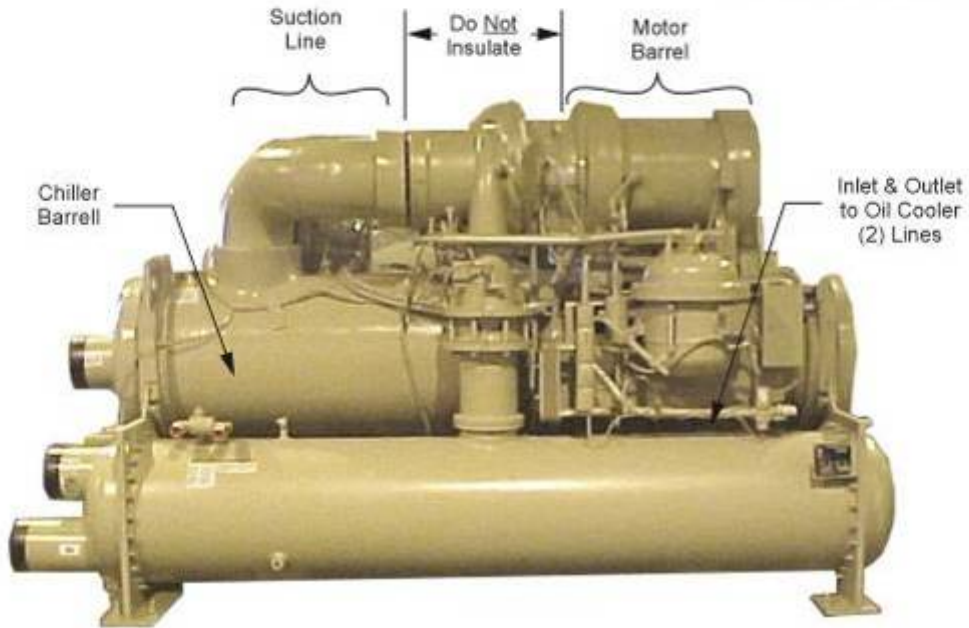

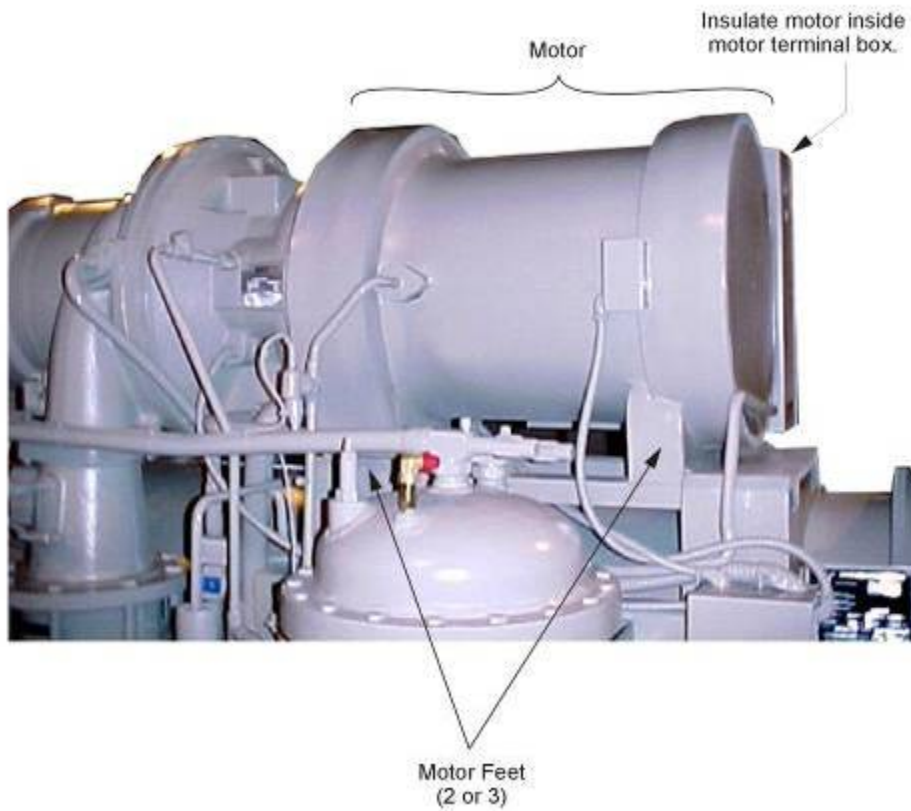
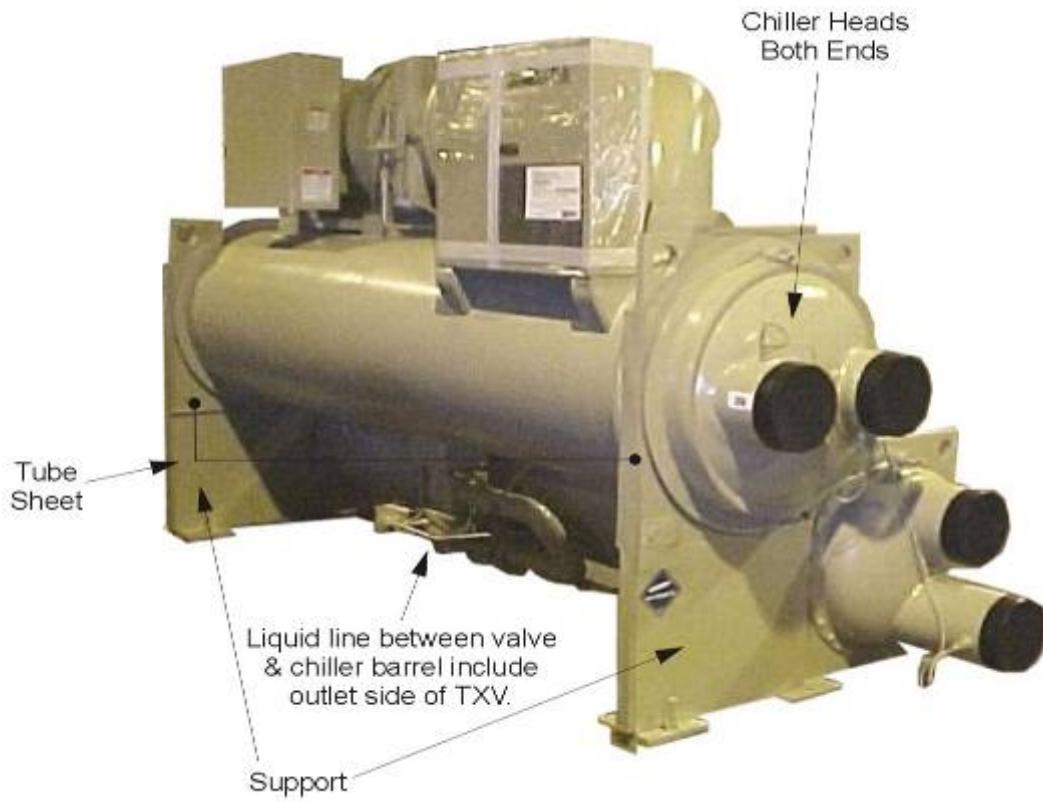

Physical Data and Weights

Evaporator

The standard insulation of cold surfaces includes the evaporator and non-connection water head, suction piping, compressor inlet, motor housing, and motor coolant outlet line.

Insulation is UL recognized (File # E55475). It is 3/4" thick ABS/PVC flexible foam with a skin. The K factor is 0.28 at 75°F. Sheet insulation is fitted and cemented in place forming a vapor barrier, then painted with a resilient epoxy finish that resists cracking.

The insulation complies to, or has been tested in accordance, with the following:

ASTM-C-177	ASTM-C-534 Type 2	UL 94-5V
ASTM-D-1056-91-2C1	ASTM E 84	MEA 186-86-M Vol. N
CAN/ULC S102-M88		

Refrigerant-side design pressure is 200 psi (1380 kPa) on WSC/WCC/HSC units and 180 psi (1242 kPa) on WDC units. Water-side is 150 psi (1034 kPa) on all.

In the event insulation is to be field-installed, none of the cold surfaces identified above will be factory insulated. Required field insulation is shown beginning on page 13. Approximate total square footage of insulation surface required for individual packaged chillers is tabulated by evaporator code and can be found below.

Table 2, Evaporator Physical Data

Evaporator Code	WSC	WDC	WCC	Water Volume gal (L)	Insulation Area sq ft (m ²)	Vessel Dry Weight lb (kg)	Add for MWB lb (kg)	MWB Cover Only, Weight lb (kg)	Number of Relief Valves
E2009	X			31 (117)	82 (7.6)	2543 (1152)	478 (217)	148 (67)	1
E2012	X			37 (139)	84 (7.8)	2862 (1296)	478 (217)	148 (67)	1
E2209	X			38 (145)	66 (6.1)	2708 (1227)	600 (272)	175 (79)	1
E2212	X			45 (170)	90 (8.3)	3071 (1391)	600 (272)	175 (79)	1
E2216		X		79 (301)	144 (13.4)	4200 (1903)	600 (272)	175 (79)	1
E2416		X		110 (415)	157 (14.6)	5170 (2343)	700 (317)	240 (109)	1
E2609	X			61 (231)	76 (7.1)	3381 (1532)	899 (407)	302 (137)	1
E2612	X			72 (273)	102 (9.4)	3880 (1758)	899 (407)	302 (137)	1
E2616		X		126 (478)	162 (15.0)	5645 (2558)	899 (407)	302 (137)	1
E3009	X			74 (281)	86 (8.0)	4397 (1992)	1386 (628)	517 (234)	1
E3012	X			89 (336)	115 (10.6)	5075 (2299)	1386 (628)	517 (234)	1
E3016		X		157 (594)	207 (19.2)	7085 (3211)	1386 (628)	517 (234)	2
E3609	X			128 (484)	155 (14.4)	5882 (2665)	2115 (958)	805 (365)	1
E3612	X			152 (574)	129 (11.9)	6840 (3099)	2115 (958)	805 (365)	1
E3616		X		243 (918)	239 (22.2)	9600 (4351)	2115 (958)	805 (365)	2
E3620			X	219 (827)	207 (19.2)	8298 (3764)	2115 (958)	805 (365)	2
E4212	X			222 (841)	148 (13.7)	8922 (4042)	2836 (1285)	1181 (535)	1
E4216		X		347 (1313)	264 (24.5)	12215 (5536)	2836 (1285)	1181 (535)	2
E4220		X		481 (1819)	330 (30.6)	15045 (6819)	2836 (1285)	1181 (535)	2
E4220			X	319 (1208)	242 (22.5)	10853 (4923)	2836 (1285)	1181 (535)	2
E4812	X			327 (1237)	169 (15.6)	11125 (5040)	4578 (2074)	1837 (832)	2
E4816		X		556 (2106)	302 (281)	16377 (7429)	4578 (2074)	1837 (832)	2
E4820		X		661 (2503)	377 (35.0)	17190 (7791)	4578 (2074)	1837 (832)	2
E4820			X	456 (1728)	276 (25.6)	14618 (6630)	4578 (2074)	1837 (832)	2

Notes:

1. Water capacity is based on standard tube configuration and standard heads and may vary depending on tube counts.
2. Vessel weight includes the shell, maximum tubes, and standard heads, no refrigerant.
3. MWB, marine water box, weight add is the water box weight minus a standard dished head weight.

Condenser

With positive pressure systems, the pressure variance with temperature is always predictable, and the vessel design and relief protection are based upon pure refrigerant characteristics. R-134a requires ASME vessel design, inspection and testing and uses spring-loaded pressure relief valves. When an over pressure condition occurs, spring-loaded relief valves purge only that refrigerant required to reduce system pressure to their set pressure, and then close.

Refrigerant side design pressure is 200 psi (1380 kPa) on WSC/WCC/HSC units and 225 psi (1552 kPa) on WDC units. Water side design is 150 psi (1034 kPa) on all.

Pumpdown

To facilitate compressor service, all Daikin centrifugal chillers are designed to permit pumpdown and isolation of the entire refrigerant charge in the unit's condenser. Dual compressor units and single compressor units equipped with the optional suction shutoff valve can also be pumped down into the evaporator.

Table 3, Condenser Physical Data

Condenser Code	WSC	WDC	WCC	Pumpdown Capacity lb. (kg)	Water Capacity gal. (L)	Vessel Weight lb. (kg)	Number of Relief Valves
C1809	X			597 (271)	43 (162)	1887 (856)	2
C1812	X			845 (384)	44 (166)	2050 (930)	2
C2009	X			728 (330)	47 (147)	1896 (860)	2
C2012	X			971 (440)	62 (236)	2528 (1147)	2
C2209	X			822 (372)	73 (278)	2596 (1169)	2
C2212	X			1183 (537)	76 (290)	2838 (1287)	2
C2216		X		1489 (676)	114 (430)	3861 (1751)	2
C2416		X		1760 (799)	143 (540)	4647 (2188)	2
C2609	X			1242 (563)	83 (314)	2737 (1245)	2
C2612	X			1656 (751)	111 (419)	3650 (1660)	2
C2616		X		2083 (945)	159 (603)	5346 (2425)	2
C3009	X			1611 (731)	108 (409)	3775 (2537)	2
C3012	X			2148 (975)	144 (545)	5033 (3383)	2
C3016		X		2789 (1265)	207 (782)	6752 (3063)	4
C3612	X			2963 (1344)	234 (884)	7095 (3219)	2
C3616		X		3703 (1725)	331 (1251)	9575 (4343)	4
C3620			X	4628 92100)	414 (1567)	12769 (5797)	4
C4212	X			3796 (1722)	344 (1302)	9984 (4529)	2
C4216		X		5010 (2273)	475 (1797)	12662 (5743)	4
C4220		X		5499 (2494)	634 (2401)	17164 (7785)	4
C4220			X	5499 (2497)	634 (2400)	17964 (8156)	4
C4812	X			4912 (2228)	488 (1848)	12843 (5826)	4
C4816		X		5581 (2532)	717 (2715)	18807 (8530)	4
C4820		X		7034 (3191)	862 (3265)	23106 (10481)	4
C4820			X	8307 (3768)	727 (2753)	18907 (8576)	4

1. Condenser pumpdown capacity based on 90% full at 90°F.
2. Water capacity based on standard configuration and standard heads and may vary depending on tube counts.
3. See Relief Valves section for additional information.

Compressor

Table 4, Compressor Weights

Compressor Size ⇒	063	079	087	100	113	126
Weight lb. (kg) ⇒	2000 (908)	3200 (1440)	3200 (1440)	6000 (2700)	6000 (2700)	6000 (2700)

Complete Unit Physical Data

Table 5 Unit Weights, Single Compressor, WSC

Unit	Evaporator / Condenser Size	Unit Refrig. Charge (1) Lbs. (kg)	Max. Unit Weight Without Starter		Max. Unit Weight With Starter (Note)	
			Shipping lbs. (kg)	Operating lbs. (kg)	Shipping lbs. (kg)	Operating lbs. (kg)
WSC063	2009 / 1809	410 (186)	8412 (3816)	8949 (4059)	9612 (4360)	10149 (4604)
WSC063	2012 / 1812	539 (244)	9284 (4211)	9955 (4516)	10484 (4756)	11155 (5060)
WSC063	2209 / 2009	479 (217)	9119 (4136)	9841 (4464)	10319 (4681)	11040 (5008)
WSC063	2212 / 2012	631 (286)	10182 (4619)	11077 (5025)	11382 (5163)	12277 (5569)
WSC063	2209 / 2209	495 (224)	9416 (4271)	10235 (4643)	10616 (4815)	11435 (5187)
WSC063	2212 / 2212	651 (295)	10557 (4789)	11570 (5248)	11757 (5333)	12770 (5792)
WSC063	2609 / 2209	651 (295)	10248 (4648)	11258 (5107)	11448 (5193)	12458 (5651)
WSC063	2612 / 2212	859 (389)	11577 (5251)	12817 (5806)	12777 (5796)	14017 (6358)
WSC063	2609 / 2609	686 (311)	10984 (4982)	12228 (5547)	12184 (5527)	13428 (6091)
WSC063	2612 / 2612	905 (410)	12494 (5667)	14020 (6359)	13694 (6203)	15220 (6904)
WSC063	3009 / 2609	825 (374)	12892 (5848)	14246 (6462)	14092 (6392)	15446 (7006)
WSC063	3012 / 2612	1098 (497)	13903 (6306)	15569 (7062)	15103 (6851)	16769 (7606)
WSC079	2209 / 2209	495 (224)	10140 (4600)	10959 (4971)	11340 (5144)	12159 (5515)
WSC079	2212 / 2212	651 (295)	11281 (5117)	12294 (5577)	12481 (5661)	13494 (6121)
WSC079	2609 / 2209	651 (295)	10980 (4981)	11990 (5439)	12180 (5525)	13190 (5983)
WSC079	2612 / 2212	859 (389)	12309 (5592)	13548 (6145)	13509 (6128)	14749 (6690)
WSC079	2609 / 2609	686 (311)	11716 (5314)	12960 (5879)	12916 (5859)	14160 (6423)
WSC079	2612 / 2612	905 (410)	13226 (5999)	14752 (6692)	14426 (6544)	15952 (7236)
WSC079	3009 / 2609	825 (374)	12892 (5848)	14246 (6462)	14092 (6392)	15446 (7006)
WSC079	3012 / 2612	1098 (497)	14635 (6638)	16301 (7394)	15835 (7183)	17501 (7938)
WSC079	3009 / 3009	855 (387)	14076 (6385)	15644 (7096)	15276 (6929)	16844 (7640)
WSC079	3012 / 3012	1147 (520)	16119 (7312)	18061 (8192)	17319 (7856)	19261 (8737)
WSC079	3609 / 3009	1173 (531)	15913 (7218)	17929 (8133)	17113 (7762)	19129 (8677)
WSC079	3612 / 3012	1563 (708)	18340 (8319)	20807 (9438)	19540 (8863)	22007 (9982)
WSC087	2609 / 2209	651 (295)	10980 (4981)	11990 (5439)	12180 (5525)	13190 (5983)
WSC087	2612 / 2212	859 (389)	12309 (5583)	13549 (6146)	13509 (6128)	14749 (6690)
WSC087	2609 / 2609	686 (311)	11716 (5314)	12960 (5879)	12916 (5859)	14160 (6423)
WSC087	2612 / 2612	905 (410)	13226 (5999)	14752 (6692)	14426 (6544)	15952 (7073)
WSC087	3009 / 2609	825 (374)	12892 (5848)	14246 (6462)	14092 (6392)	15446 (7006)
WSC087	3012 / 2612	1098 (497)	14635 (6638)	16301 (7394)	15835 (7183)	17501 (7938)
WSC087	3009 / 3009	862 (390)	14076 (6385)	15644 (7096)	15276 (6929)	16844 (7640)
WSC087	3012 / 3012	1147 (520)	16118 (7311)	18060 (8192)	17318 (7855)	19260 (8736)
WSC087	3609 / 3009	1173 (531)	15913 (7218)	17929 (8133)	17113 (7762)	19129 (8677)
WSC087	3612 / 3012	1563 (708)	18339 (8319)	20806 (9438)	19539 (8863)	22006 (9982)
WSC087	3612 / 3612	1635 (740)	20584 (9337)	23799 (10795)	21784 (9881)	24999 (11340)
WSC100	3612 / 3012	1563 (708)	21578 (9788)	24045 (10907)	22778 (10332)	25245 (11451)
WSC100	3612 / 3612	1635 (740)	23826 (10807)	27041 (12266)	25026 (11352)	28241 (12810)
WSC100	4212 / 3612	2081 (943)	26457 (12001)	30260 (13726)	27657 (13545)	31460 (14270)
WSC100	4212 / 4212	2164 (980)	29298 (13290)	34024 (15433)	30498 (13834)	35224 (15978)
WSC100	4812 / 4212	2688 (1217)	32024 (14526)	37623 (17066)	33224 (15070)	38823 (17610)
WSC113	3612 / 3012	1563 (708)	21578 (9788)	24045 (10907)	22778 (10332)	25245 (11451)
WSC113	3612 / 3612	1635 (740)	23826 (10807)	27041 (12266)	25026 (11352)	28241 (12810)
WSC113	4212 / 3612	2081 (943)	26457 (12001)	30260 (13726)	27657 (13545)	31460 (14270)
WSC113	4212 / 4212	2164 (980)	29298 (13290)	34024 (15433)	30498 (13834)	35224 (15978)
WSC113	4812 / 4212	2688 (1217)	32024 (14526)	37623 (17066)	33224 (15070)	38823 (17610)
WSC113	4812 / 4812	2867 (1299)	35016 (15883)	41817 (18968)	36216 (16427)	43017 (19513)
WSC126	3612 / 3012	1563 (708)	21680 (9834)	24147 (10953)	22880 (10378)	25347 (11497)
WSC126	3612 / 3612	1635 (740)	23928 (10854)	27143 (12312)	25128 (11398)	28343 (12856)
WSC126	4212 / 3612	2081 (943)	26457 (12001)	30260 (13726)	27657 (12545)	31460 (14270)
WSC126	4212 / 4212	2164 (980)	29298 (13290)	34024 (15433)	30498 (13834)	35224 (15978)
WSC126	4812 / 4212	2164 (980)	32024 (14526)	37623 (17066)	33224 (15070)	38823 (17610)
WSC126	4812 / 4812	2867 (1299)	35016 (15883)	41817 (18968)	36216 (16427)	43017 (19513)

Note: With starters (factory mounted) applies only to low voltage (200 to 600 volts) equipment.

Table 6 Unit Weights, Dual Compressor, WDC/WCC

Unit	Evaporator / Condenser Size	Max. Unit Weight Without Starter		Max. Unit Weight With Starter (Note 1)	
		Shipping lbs. (kg)	Operating lbs. (kg)	Shipping lbs. (kg)	Operating lbs. (kg)
WDC063	2416 / 2416	18673 (8470)	20422 (9263)	21407 (9710)	23156 (10503)
WDC063	2416 / 2616	19365 (8784)	21294 (9577)	22099 (10024)	23848 (10817)
WDC063	2616 / 2416	19282 (8746)	21207 (9639)	22016 (9986)	23763 (10779)
WDC063	2616 / 2616	20025 (9083)	22091 (9939)	22759 (10323)	24646 (11179)
WDC063	3016 / 3016	23545 (10680)	26405 (11830)	26279 (11920)	28815 (13070)
WDC063	3616 / 3016	27763 (12604)	31018 (14082)	30163 (13694)	33418 (15172)
WDC063	3616 / 3616	32027 (14540)	35115 (15942)	33427 (15176)	37515 (17032)
WDC079	3016 / 3016	25131 (11399)	27671 (12551)	27531 (12488)	30071 (13640)
WDC079	3616 / 3016	28763 (13047)	32018 (14523)	31163 (14135)	34418 (15612)
WDC079	3616 / 3616	32027 (14527)	36115 (16382)	34427 (15616)	38515 (17470)
WDC079	4216 / 4216	44470 (20189)	51463 (23364)	47204 (21431)	54197 (24605)
WDC087	3016 / 3016	26157 (11865)	28697 (13017)	28891 (13105)	31431 (14257)
WDC087	3616 / 3016	29789 (13512)	33044 (14989)	32523 (14752)	35778 (16322)
WDC087	3616 / 3616	33053 (14993)	37141 (16847)	35787 (16233)	39875 (18087)
WDC087	4216 / 4216	44470 (20189)	51463 (23364)	47204 (21431)	54197 (24605)
WDC100, 113	3616 / 3616	41816 (18967)	46513 (21098)	See Note 2	See Note 2
WDC100, 113, 126 (<7kV)	4216 / 4216	50470 (22893)	57463 (26065)	See Note 2	See Note 2
WDC100, 113, 126 (<7kV)	4816 / 4816	59185 (26846)	68996 (31296)	See Note 2	See Note 2
WDC100, 113, 126 (<7kV)	4220 / 4220	54802 (24858)	63248 (28689)	See Note 2	See Note 2
WDC100, 113, 126 (<7kV)	4820 / 4820	65964 (29921)	77698 (35243)	See Note 2	See Note 2
WCC100, 113, 126 (<7kV)	3620 / 3620	37645 (17091)	41334 (19268)	See Note 2	See Note 2
WCC100, 113, 126 (<7kV)	4220 / 3620	41320 (18759)	45609 (21317)	See Note 2	See Note 2
WCC100, 113, 126 (<7kV)	4220 / 4220	45314 (20573)	50281 (23767)	See Note 2	See Note 2
WCC100, 113, 126 (<7kV)	4820 / 4220	49759 (22590)	56173 (26305)	See Note 2	See Note 2
WCC100, 113, 126 (<7kV)	4820 / 4820	55927 (25391)	62528 (29876)	See Note 2	See Note 2
WDC100, 113, 126 (10/11kV)	4216/4216	55760 (25292)	63536 (28219)	See Note 2	See Note 2
WDC100, 113, 126 (10/11kV)	4220/4220	62136 (28184)	71426 (32398)	See Note 2	See Note 2
WDC100, 113, 126 (10/11kV)	4820/4820	73526 (33351)	86282 (39137)	See Note 2	See Note 2
WCC100, 113, 126 (10/11kV)	4220/4220	55987 (25395)	63262 (28695)	See Note 2	See Note 2
WCC100, 113, 126 (10/11kV)	4820/4820	65768 (29832)	75761 (34365)	See Note 2	See Note 2

Notes:

1. With starters (factory mounted) applies only to low voltage (200 to 600 volts) equipment.
2. Unit not available with factory mounted starters.

Oil Coolers

⚠ WARNING

This unit contains POE lubricants that must be handled carefully and the proper protective equipment (gloves, eye protection, etc.) must be used when handling POE lubricant. POE must not come into contact with any surface or material that might be harmed by POE, including certain polymers (e.g. PVC/CPVC and polycarbonate piping).

Daikin centrifugal chillers have a factory-mounted, water-cooled oil cooler, temperature-controlled water regulating valve and solenoid valve per compressor. WSC/HSC single compressor cooling water connections are located near the compressor and are shown on the specific unit certified drawings. Also see Figure 11 on page 21. Dual compressor chillers, WDC/ 063 - 126 and WCC 100 - 126 are equipped as above, but the water piping for the two oil coolers is factory-piped to a common inlet and outlet connection located in the tube sheet under the evaporator. The exception to this is the WDC 100 and 126 with 16-foot shells, where the common connections are centered at the rear of the unit. See Figure 12 on page 21.

Field water piping to the inlet and outlet connections must be installed according to good piping practices and include stop valves to isolate the cooler for servicing. A cleanable filter (40 mesh maximum), and drain valve or plug must also be field-installed. The water supply for the oil cooler should be from the chilled water circuit or from a clean, independent source, no warmer than 80°F (27°C), such as city water. When using chilled water, it is important that the water pressure drop across the evaporator is greater than the pressure drop across the oil cooler or insufficient oil cooler flow will result. If the pressure drop across the evaporator is less than the oil cooler, the oil cooler must be piped across the chilled water pump, provided that its pressure drop is sufficient. The water flow through the oil cooler will be adjusted by the unit's regulating valve so that the temperature of oil supplied to the compressor bearings (leaving the oil cooler) is between 95°F and 105°F (35°C and 40°C).

NOTE: The system must be designed for the highest cooling water temperature possible, which may occur for a short time during startup.

Table 7, WSC, Oil Cooler Data

	Hot Side POE Lube	Cold Side Water			
WSC 063 - 087					
Flow, gpm	9.9	11.9	2.9	2.0	1.54
Inlet Temperature, °F	118.0	80.0	65.0	55.0	45.0
Outlet Temperature, °F	100.0	87.3	94.5	98.3	101.4
Pressure Drop, psi	-	4.3	0.3	0.14	0.09
WSC 100 - 126					
Flow, gpm	15.8	21.9	5.11	3.5	2.7
Inlet Temperature, °F	120.0	80.0	65.0	55.0	45.0
Outlet Temperature, °F	100.0	87.0	95.0	99.0	102.3
Pressure Drop, psi	-	3.78	0.23	0.11	0.07

Table 8, WSC with Mounted VFD, Oil Cooler Data

	Hot Side POE Lub.	Cold Side Water			
WSC/HSC 063 - 087					
Flow, gpm	9.9	13.4	4.0	2.9	2.3
Inlet Temperature, °F	118.0	80.0	65.0	55.0	45.0
Outlet Temperature, °F	100.0	90.3	99.6	103.1	105.6
Pressure Drop, ft.	-	30.5	6.7	4.8	3.6
WSC/HSC 100 - 126					
Flow, gpm	15.8	24.4	7.0	5.0	4.0
Inlet Temperature, °F	120.0	80.0	65.0	55.0	45.0
Outlet Temperature, °F	100.0	89.8	100.1	103.6	106.2
Pressure Drop, ft.	-	30.6	15.7	11.4	9.3

NOTE:

1. Dual compressor units have twice the cooling water flow of the comparable WSC chiller, the pressure drop will be the same. Pressure drops include valves on the unit.

Table 9, Freestanding VFD, Cooling Requirements

	Cooling Water	Cooling Water	Cooling Water	Cooling Water
WSC/HSC 063 - 087				
Flow, gpm	1.5	1.0	0.9	0.7
Inlet Temperature, °F	80.0	65.0	55.0	45.0
Outlet Temperature, °F	114	114	114	114
Pressure Drop, ft.	13.0	6.8	4.8	3.6
WSC/HSC 100 - 126				
Flow, gpm	2.5	1.9	1.5	1.3
Inlet Temperature, °F	80.0	65.0	55.0	45.0
Outlet Temperature, °F	114	114	114	114
Pressure Drop, ft.	25.2	15.7	11.4	9.3

Compressors using chilled water for oil cooling will often start with warm "chilled water" in the system until the chilled water loop temperature is pulled down. Data given above includes that condition. As can be seen, with cooling water in the 45°F to 65°F (7°C to 18°C) range, considerably less water will be used, and the pressure drop will be greatly reduced.

When supplied with city water, the oil piping must discharge through a trap into an open drain to prevent draining the cooler by siphoning. The city water can also be used for cooling tower makeup by discharging it into the tower sump from a point above the highest possible water level.

NOTE: Particular attention must be paid to chillers with variable chilled water flow through the evaporator. The pressure drop available at low flow rates can very well be insufficient to supply the oil cooler with enough water. In this case an auxiliary booster pump can be used or city water employed.

Figure 9, Oil Cooler Piping Across Chilled Water Pump

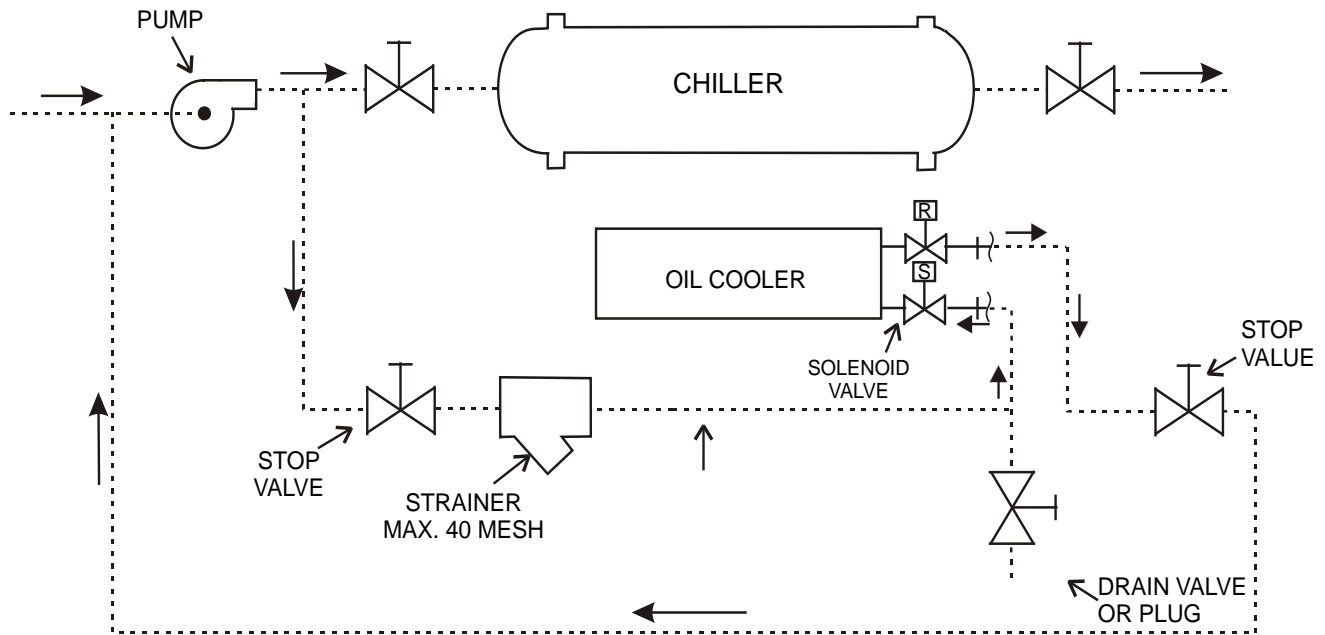

Figure 10, Oil Cooler Piping With City Water

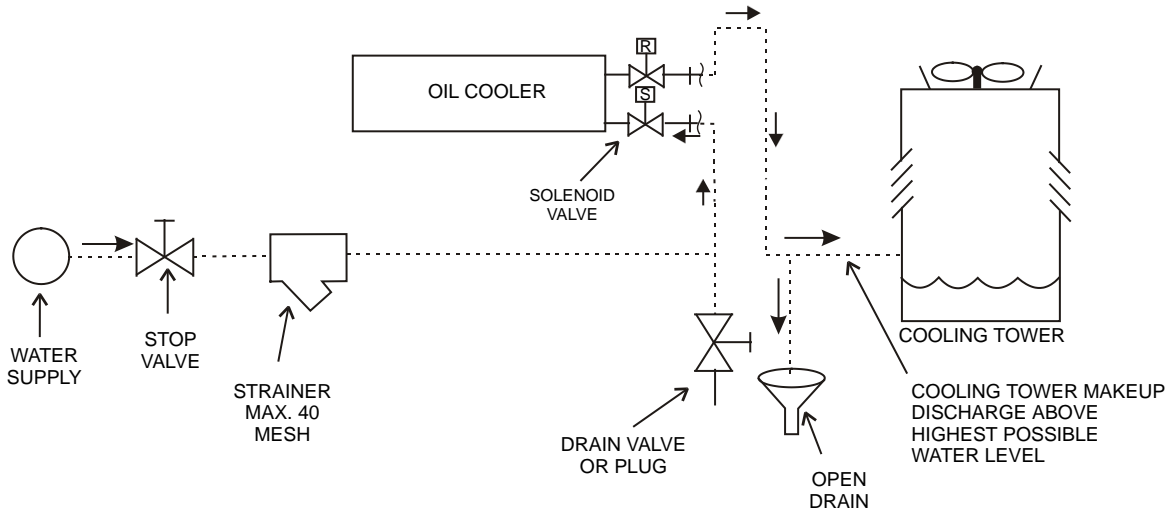

Figure 11, Oil Cooler Connections, WSC/HSC Units

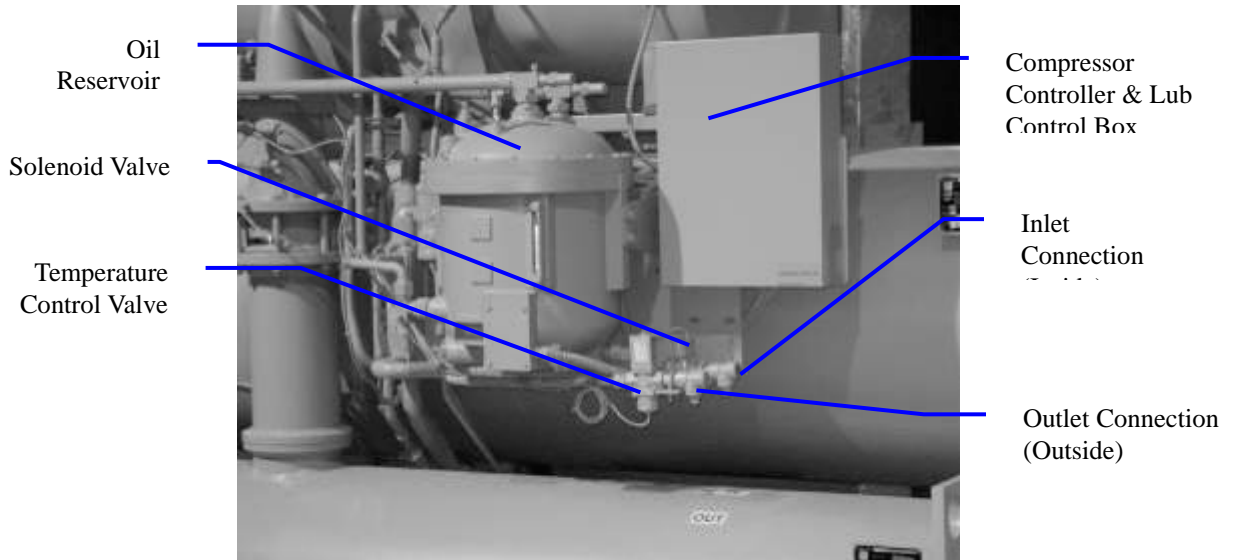
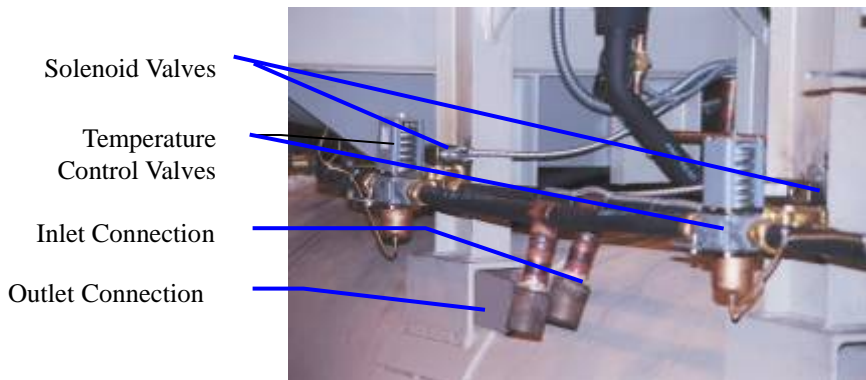

Figure 12, Oil Cooler Connections, WDC 100/126, 16 Foot Shells



Note:
All other WDC units have oil cooler connections located on the right hand tube sheet under the evaporator.

Table 10, Cooling Water Connection Sizes

Model	WSC/HSC 063-087,	WDC 063-087, WSC/HSC 100-126	WDC/WCC 100-126
Conn Size (in.)	3/4 in.	1 in.	1 1/2 in.

Oil Heater

The oil sump is equipped with an immersion heater that is installed in a tube so that it can be removed without disturbing the oil.

Relief Valves

As a safety precaution and to meet code requirements, each chiller is equipped with pressure relief valves located on the condenser, evaporator, and oil sump vessel for the purpose of relieving excessive refrigerant pressure (caused by equipment malfunction, fire, etc.) to the atmosphere. Most codes require that relief valves be vented to the outside of a building, and this is a desirable practice for all installations. Relief piping connections to the relief valves must have flexible connectors.

Note: Remove plastic shipping plugs (if installed) from the inside of the valves prior to making pipe connections. Whenever vent piping is installed, the lines must be run in accordance with local code requirements; where local codes do not apply, the latest issue of ANSI/ASHRAE Standard 15 code recommendations must be followed.

Condensers have two relief valves as a set with a three-way valve separating the two valves (large condensers will have two such sets). One valve remains active at all times and the second valve acts as a standby. See pages 15 and 16 for the number of valve on specific vessels.

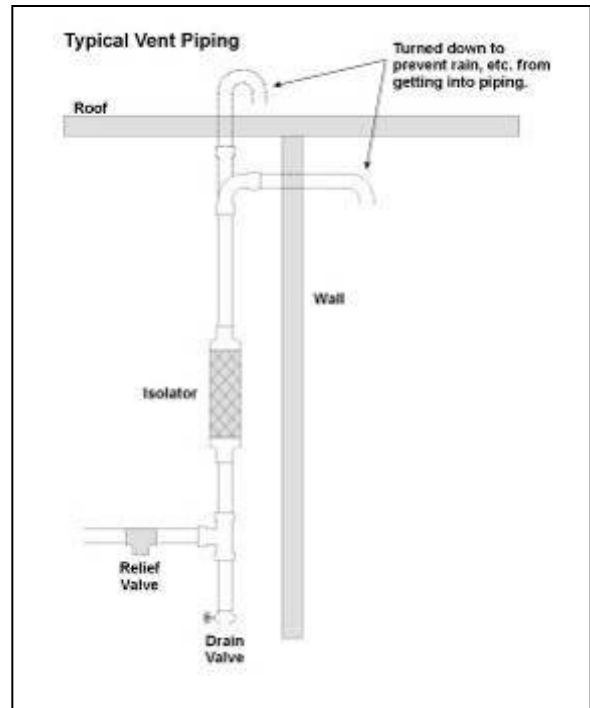
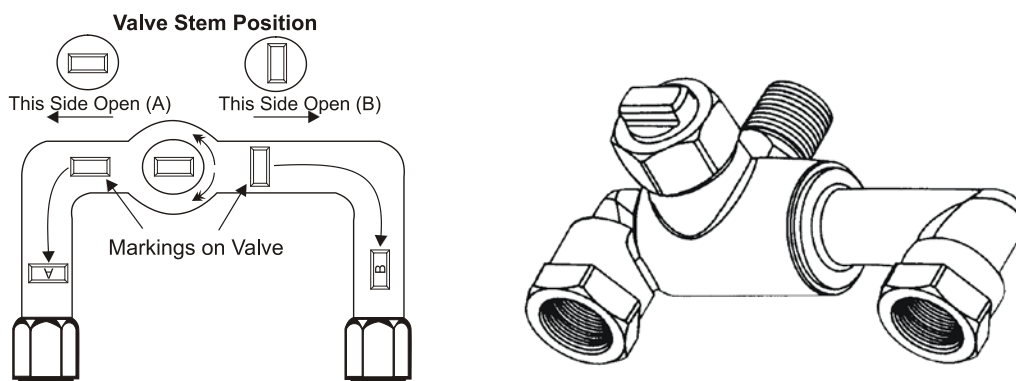

Table 11, Relief Valve Data

Chiller	Relief Valve	Location	Pressure Setting	Discharge Cap.
WSC/WPV	Evaporator	Top of Evaporator	200 psi	75.5 lb air/min
	Condenser	Top of Condenser	200 psi	75.5 lb air/min
WDC	Evaporator	Top of Evaporator	180 psi	68.5 lb air/min
	Condenser	Top of Condenser	225 psi	84.4 lb air/min
Oil Sump	Oil Pump	Top of Oil Sump Cover	200 psi	5.0 lb air/min

Figure 13, Condenser 3-Way Valve



Refrigerant Vent Piping

Relief valve connection sizes are one-inch FPT and are in the quantity shown in Table 2 and Table 3 on page 15. Twin relief valves mounted on a transfer valve are used on the condenser so that one relief valve can be shut off and removed, leaving the other in operation. Only one of the two is in operation at any time. Where four valves are shown in the table, they consist of two valves, each mounted on two transfer valves. Only two relief valves of the four are active at any time.

Vent piping is sized for only one valve of the set since only one can be in operation at a time. In no case would a combination of evaporator and condenser sizes require more refrigerant than the pumpdown capacity of the condenser. Condenser pumpdown capacities are based on the current ANSI/ASHRAE Standard 15 that recommends 90% full at 90°F (32°C). To convert values to the older AHRI standard, multiply pumpdown capacity by 0.888.

Sizing Vent Piping (ASHRAE Method)

Relief valve pipe sizing is based on the discharge capacity for the given evaporator or condenser and the length of piping to be run. Discharge capacity for R-134a vessels is calculated using a complicated equation that accounts for equivalent length of pipe, valve capacity, Moody friction factor, pipe ID, outlet pressure and back pressure. The formula, and tables derived from it, is contained in ASHRAE Standard 15.

Daikin centrifugal units have relief valve settings of 180 psi, 200 psi, and 225 psi, and resultant valve discharge capacities of 68.5 # air/min, 75.5 # air/min, and 84.4 # air/min respectively.

Using the ASHRAE formula and basing calculations on the 225 psi design yields a conservative pipe size, which is summarized in Table 12. The table gives the pipe size required *per relief valve*. When valves are piped together, the common piping must follow the rules set out in the following paragraph on common piping.

Table 12, Relief Valve Piping Sizes

Equivalent length (ft)	2.2	18.5	105.8	296.7	973.6	4117.4
Pipe Size inch (NPT)	1 1/4	1 1/2	2	2 1/2	3	4
Moody Factor	0.0209	0.0202	0.0190	0.0182	0.0173	0.0163

NOTE: A 1-inch pipe is too small for the flow from the valves. A pipe increaser must always be installed at the valve outlet.

Common Piping

According to ASHRAE Standard 15, the pipe size cannot be less than the relief valve outlet size. The discharge from more than one relief valve can be run into a common header, the area of which cannot be less than the sum of the areas of the connected pipes. For further details, refer to ASHRAE Standard 15. The common header can be calculated by the formula:

$$D_{Common} = \left(D_1^2 + D_2^2 \dots D_n^2 \right)^{0.5}$$

The above information is a guide only. Consult local codes and/or latest version of ASHRAE Standard 15 for sizing data.

Electrical

Wiring, fuse and wire size must be in accordance with the National Electric Code (NEC). Standard NEMA motor starters require modification to meet Daikin specifications. Refer to Daikin Specification R359999 Rev 29 available from the local Daikin sales representative.

Important: Voltage unbalance not to exceed 2% with a resultant current unbalance of 6 to 10 times the voltage unbalance per NEMA MG-1 Standard. This is an important restriction that must be adhered to.

Power Wiring

Power Factor Correction Capacitors

Do not use power factor correction capacitors with centrifugal chillers with a compressor VFD. Doing so can cause harmful electrical resonance in the system. Correction capacitors are not necessary since VFDs inherently maintain high power factors



WARNING

Qualified and licensed electricians must perform wiring. Shock hazard exists.

Power wiring to compressors must be in proper phase sequence. Motor rotation is set up for clockwise rotation facing the lead end with phase sequence of 1-2-3. Care must be taken that the proper phase sequence is carried through the starter to compressor. With the phase sequence of 1-2-3 and L1 connected to T1 and T6, L2 connected to T2 and T4, and L3 connected to T3 and T5, rotation is proper. See diagram in terminal box cover.

The start-up technician will determine the phase sequence.



CAUTION

Connections to terminals must be made with copper lugs and copper wire.

Care must be taken when attaching leads to compressor terminals.

Use only copper supply wires with ampacity based on 75°C conductor rating. (Exception: for equipment rated over 2000 volts, 90°C or 105°C rated conductors should be used).

Note: For installing remote-mounted, free-standing starters see Daikin manual IOMM 1158; for VFDs see Daikin manual IOMM 1159.

Note: Do not make final connections to motor terminals until wiring has been checked and approved by a Daikin technician.

Under no circumstances should a compressor be brought up to speed unless proper sequence and rotation have been established. Serious damage can result if the compressor starts in the wrong direction. Such damage is not covered by product warranty.

600 +Volts Motor Insulation

It is the installing contractor's responsibility to insulate the compressor motor terminals when the unit voltage is 600 volts or greater. This is to be done after the Daikin start-up technician has checked for proper phase sequence and motor rotation. Following this verification by the Daikin technician, the contractor should obtain and apply the following items on medium voltage (above 600 volts) applications.

Materials required:

1. Loctite® brand safety solvent (12 oz. package available as Daikin part number 350A263H72)
2. 3M™ Co. Scotchfil™ brand electrical insulation putty (available in a 60-inch roll as Daikin part number 350A263H81)
3. 3M Co. Scotchkote™ brand electrical coating (available in a 15 oz. can with brush as Daikin Part Number 350A263H16)
4. Vinyl plastic electrical tape

The above items are available at most electrical supply outlets.

Application procedure:

- 1) Disconnect and lock out the power source to the compressor motor.
- 2) Using the safety solvent, clean the motor terminals, motor barrel adjacent to the terminals, lead lugs, and electrical cables within the terminal 4OX to remove all dirt, grime, moisture and oil.
- 3) Wrap the terminal with Scotchfil putty, filling in all irregularities. The final result should be smooth and cylindrical.
- 4) Doing one terminal at a time, brush the Scotchkote coating on the motor barrel to a distance of up to 1/2" around the terminal and on the wrapped terminal, the rubber insulation next to the terminal, and the lug and cable for approximately 10". Wrap additional Scotchfil insulation over the Scotchkote coating.
- 5) Tape the entire wrapped length with electrical tape to form a protective jacket.
- 6) Finally, brush on one more coat of Scotchkote coating to provide an extra moisture barrier.

Installation Instructions for 10/11kV Motor Units

The 10/11 kV motors have additional installation requirements compare to lower voltage motors.

Installing Motor Terminal Box

For safety and shipping considerations, the chiller is shipped with a disposable protective shield over the motor terminals and a separate field-installed terminal box.

⚠ CAUTION

Exert extreme care when mounting the compressor motor terminal box on the compressor to avoid damage to the motor terminals. Terminal damage can result in costly and time consuming repair.

Unbolt the protective shield covering the compressor motor terminals and discard.

Install the shipped-loose terminal box as follows:

1. A mounting gasket is shipped with the terminal box. Mount it on the face of the compressor terminal housing (see Figure 14) using an appropriate adhesive to hold it in place until the terminal box is mounted. The gasket must be located such that the gasket holes align with the threaded holes in the casting.
2. Remove the terminal box door before lifting the terminal box helps to keep the box balanced. Lift using lifting straps attached to the side lifting tabs. The top tab is used as a tie-off for balance, not for the main weight of lifting.
3. To assist in mounting the box and to provide protection to the motor terminals, screw two ¼-20 x 12 in. all-thread into top and bottom holes of the casting (see Figure 14) to provide mounting guides for aligning the box
4. Mount the box over the two all-threads using them as a guide and carefully position the box against the compressor (gasket). Avoid contact with the motor terminals.
5. Mount the box using ¼-20 x 0.75 in. bolts in all the empty holes.

Figure 14, Compressor Terminal Housing

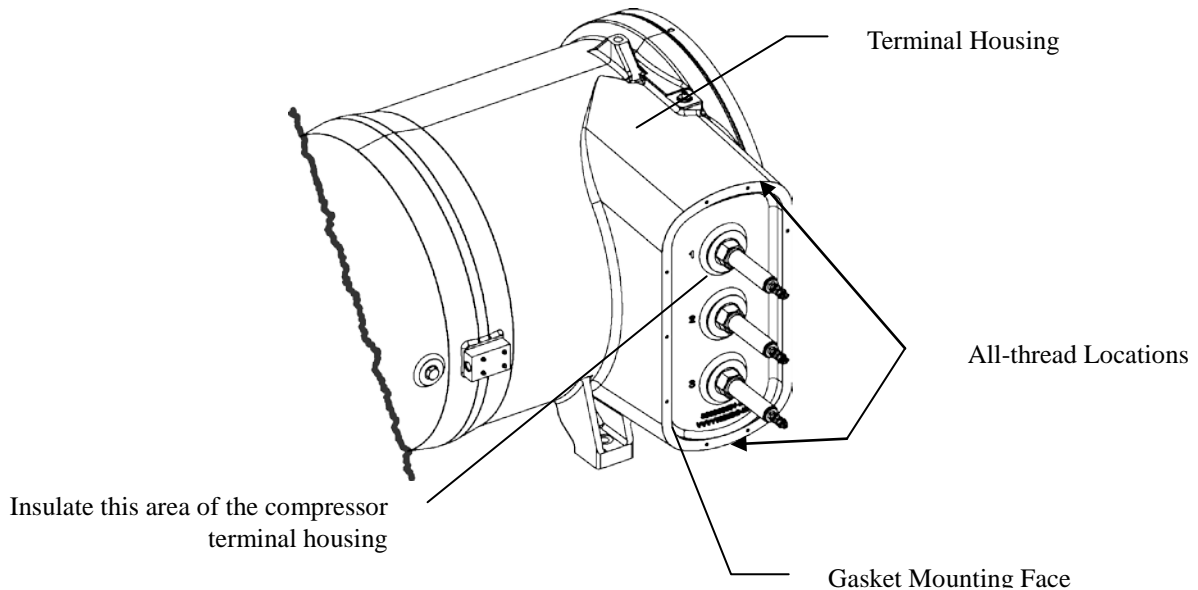

6. Remove the two all-thread and replace with two ¼-20 x 0.75 in. bolts.

Insulating Motor Terminals

1. Insulate motor housing around terminals using thermal foam.
2. Thermally insulate the motor terminals.
 - Use “SCOTCH” Sealant Tape on each end of terminal on glass.
 - Install full length plus heat shrink tube (see picture to right.)
 - Shrink with heat gun.



3. Install the flexible buss bars. (see picture at right) using a backing wrench and tighten as shown below. The buss bars are factory connected to the box main power terminals and field connected to the motor terminals

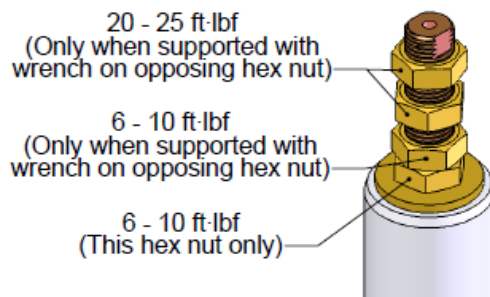

- Use Scotch® Linerless Rubber Splicing Tape to cover the compressor terminal housing extending into the terminal box. See Figure 14.
- Top wrap with “SCOTCH” Sealant Tape starting at base terminal and going out 2-in. onto the buss-bar.
- Top wrap with "SCOTCH" 70 SELF-FUSING SILICONE RUBBER ELECTRICAL TAPE 70 starting at base terminal and going out 2-in. onto the buss-bar.
- Top coat all this the 3M™ Scotchkote™ Electrical Coating 14853 (clear liquid)

Connecting Power Leads

Power leads are brought in through a removable plate on the top of the terminal box (see Figure 15). The terminal box power connectors are made to the landing points shown in Figure 15 and attached with a bolt already in the connector.

Figure 15, Terminal Box Mounted, Front View

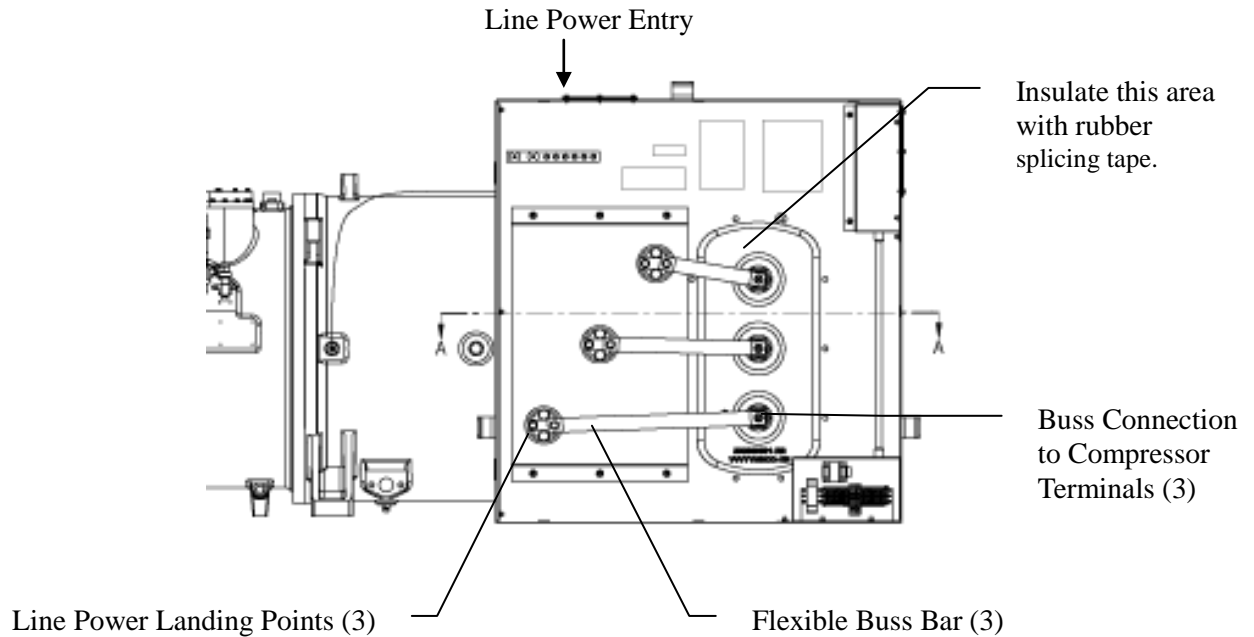
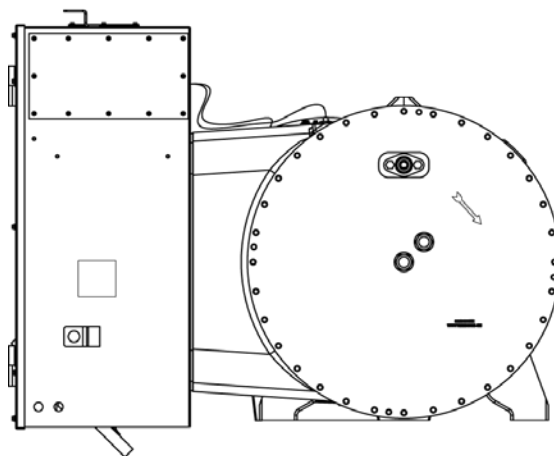

Figure 16, Terminal Box Mounted, Side View



Control Wiring

Power leads are brought in through a removable plate on the top of the terminal box (see Figure 15). The terminal box power connectors are made to the landing points shown in Figure 15 captive and attached with a bolt already in the connector.

Figure 17, Control Wiring

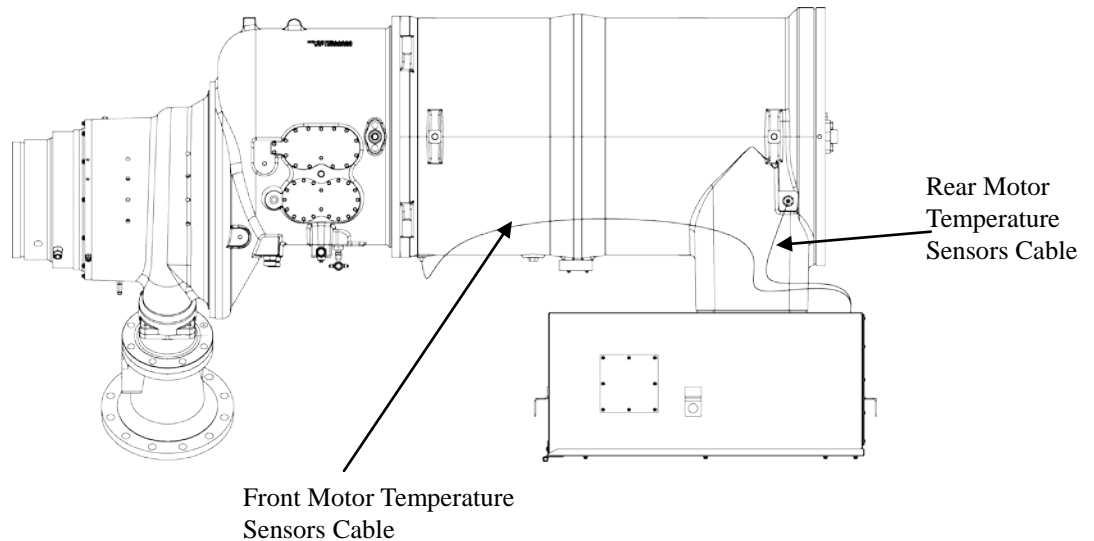

Compressor to Terminal Box

Each sensor location cable has four wires connected to the motor by a M12 4-pin connector and to the Thermistor Controller in the terminal box. Connections are as follows:

Front Temperature Sensors connect to the controller's J2 terminal strip.

Brown---B1
 White---B2
 Blue-----B3
 Black----Ground

Rear Temperature Sensors connect to the controller's J6 terminal strip.

Brown---B6
 White---B7
 Blue-----B8
 Black----Ground

Motor Terminal Box to Chiller Control Panel

Field wiring is required between the terminal box and the chiller control panel to transmit motor information to the chiller. Data from the compressor is sent to a "Black Box" fiber isolator via a factory-wired fiber optic cable (to isolate motor voltage from the chiller controls). A cable is factory connected to terminals 33, 34, 35, and 36 on CTB1 in the chiller control box. This cable is field installed into the motor terminal box and wires in it connected to like terminal numbers on terminal strip TTB1 located in the small lower box of the motor terminal box.

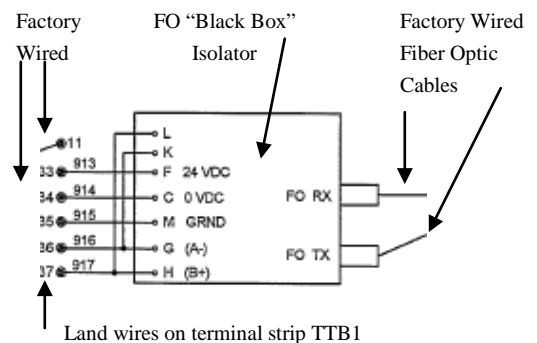

Full Metering Option

Remote mounted wye-delta, solid state, and across-the-line starters require field wiring to activate the optional ammeter display or full metering display option on the chiller's operator interface panel. The wiring is from the MX3 board in the starter to the compressor controller.

Wiring Connection on Starter for Optional Display

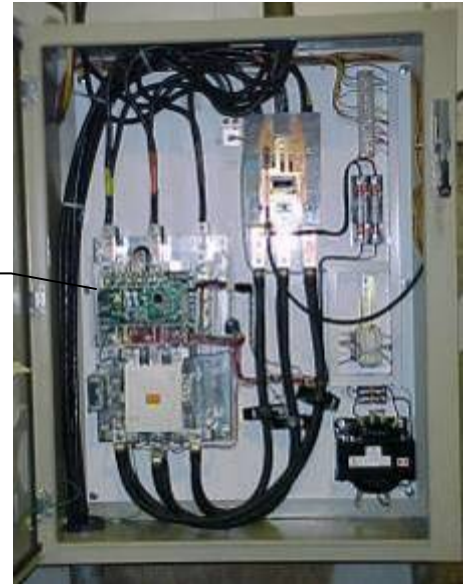
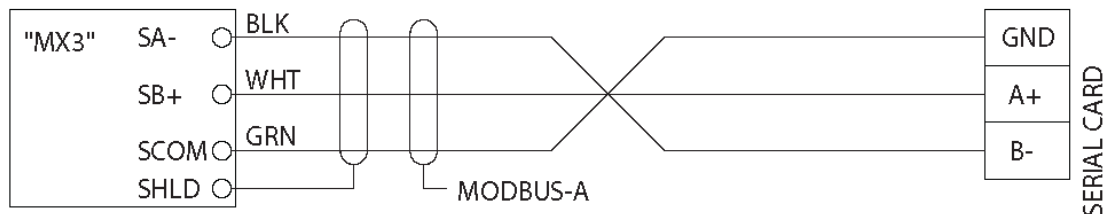

Figure 18, Wiring for Optional Display



NOTES:

- The serial card location is in the lower-center of the compressor controller located in the chiller control panel.
- The "MX3" is located in the starter.
- The connections are (-) to (-), (+) to (+) and SCOM to GND with a shield connection on the starter terminal board.
- Cable is Belden 9841 or equal (120 OHM characteristic impedance)

Control Power Wiring Options

The control circuit on the Daikin centrifugal packaged chiller is designed for 115-volts. Control power can be supplied from three different sources:

1. If the unit is supplied with a factory-mounted starter or VFD, the control circuit power supply is factory-wired from a transformer located in the starter or VFD.
2. A freestanding starter or VFD furnished by Daikin, or by the customer to Daikin specifications, will have a control transformer in it and requires field wiring to terminals in the compressor terminal box.
3. Power can be supplied from a separate circuit and fused at 25 amps inductive load. The control circuit disconnect switch must be tagged to prevent current interruption. **Other than for service work, the switch is to remain on at all times in order to keep oil heaters operative and prevent refrigerant from diluting in oil.**

DANGER

If a separate control power source is used, the following must be done to avoid severe personal injury or death from electrical shock: Place a notice on the unit that multiple power sources are connected to the unit. Place a notice on the main and control power disconnects that another source of power to the unit exists.

In the event a transformer supplies control voltage, it must be rated at 3 KVA, with an inrush rating of 12 KVA minimum at 80% power factor and 95% secondary voltage. For control wire sizing, refer to NEC. Articles 215 and 310. In the absence of complete information to permit calculations, the voltage drop should be physically measured.

Table 13, Control Power Line Sizing

Maximum Length, ft (m)	Wire Size (AWG)	Maximum Length, ft (m)	Wire Size (AWG)
0 (0) to 50 (15.2)	12	120 (36.6) to 200 (61.0)	6
50 (15.2) to 75 (22.9)	10	200 (61.0) to 275 (83.8)	4
75 (22.9) to 120 (36.6)	8	275 (83.8) to 350 (106.7)	3

Notes:

1. Maximum length is the distance a conductor will traverse between the control power source and the unit control panel.
2. Panel terminal connectors will accommodate up to number 10 AWG wire. Larger conductors will require an intermediate junction box.

The Unit On/Off switch located in the Unit Control Panel should be turned to the "Off" position any time compressor operation is not desired.

Wiring for Optional BAS Interface

The optional Building Automation System (BAS) interface utilizing the MicroTech II unit controller's Open Choices™ feature is field wired and will be set-up by the Daikin startup service technician. The following manuals (available on www.DaikinApplied.com) explain the wiring and mounting procedures:

LONWORKS® > IM 735

BACnet® > IM 906

MODBUS® > IM 743

Flow Switches

Water flow interlock terminals are provided on the Unit Control Panel terminal strip for field-mounted switches. See the Field Wiring Diagram on page 32 or on the cover of the control panel for proper connections. The purpose of the water flow interlocks is to prevent compressor operation until such time as both the evaporator water and condenser water pumps are running and flow is established. If flow switches are not furnished factory-installed and wired, they must be furnished and installed by others in the field before the unit can be started.

System Pumps

Operation of the chilled water pump can be to 1) cycle the pump with the compressor, 2) operate continuously, or 3) start automatically by a remote source.

The cooling tower pump must cycle with the machine. The holding coil of the cooling tower pump motor starter must be rated at 115 volts, 60 Hz, with a maximum volt-ampere rating of 100. A control relay is required if the voltage-ampere rating is exceeded. See the Field Wiring Diagram on page 32 or in the cover of control panel for proper connections.

All interlock contacts must be rated for no less than 10 inductive amps. The alarm circuit provided in the control center utilizes 115-volts AC. The alarm used must not draw more than 10 volt amperes.

See OM CentriMicro II for MicroTech II unit controller details.

Control Panel Switches

Three On/Off switches are located in the upper left corner of the main Unit Control Panel, which is adjacent to the operator interface panel, and have the following function:

- UNIT shuts down the chiller through the normal shutdown cycle of unloading the compressor(s) and provides a post-lube period.
- COMPRESSOR one switch for each compressor on a unit, executes an immediate shutdown without the normal shutdown cycle.
- CIRCUIT BREAKER disconnects optional external power to system pumps and tower fans.

A fourth switch located on the left outside of the Unit Control Panel and labeled EMERGENCY STOP SWITCH stops the compressor immediately. It is wired in series with the COMPRESSOR On/Off switch.

Surge Capacitors

All units (except those with solid state starters or VFDs) are supplied with standard surge capacitors to protect compressor motors from electrical damage resulting from high voltage spikes.

- For unit-mounted starters, the capacitors are factory-mounted and wired in the starter enclosure.
- For free-standing starters, the capacitors are mounted in the motor terminal box and must be connected to the motor terminals with leads less than 18 inches (460 mm) long when the motor is being wired.

Field Wiring, Controls & Starters

NOTES for Following Wiring Diagram

1. Compressor motor starters are either factory mounted and wired, or shipped separate for field mounting and wiring. If provided by others, starters must comply with Daikin specification 359999 Rev29. All line and load side power conductors must be copper.
2. If starters are freestanding, then field wiring between the starter and the control panel is required. Minimum wire size for 115 Vac is 12 GA for a maximum length of 50 feet. If greater than 50 feet, refer to Daikin for recommended wire size minimum. Wire size for 24 Vac is 18 GA. All wiring to be installed as NEC Class 1 wiring system. All 24 Vac wiring must be run in separate conduit from 115 Vac wiring. Main power wiring between starter and motor terminal is factory-installed when units are supplied with unit-mounted starters. Wiring of free-standing starter must be wired in accordance with NEC and connection to compressor motor terminals must be made with copper wire and copper lugs only. Control wiring on free-standing starters is terminated on a terminal strip in the motor terminal box (not the unit control panel). Wiring from the unit control panel to the motor terminal is done in the factory.
3. For optional sensor wiring, see unit control diagram. It is recommended that DC wires be run separately from 115 Vac wiring.
4. Customer furnished 24 or 120 Vac power for alarm relay coil can be connected between UTB1 terminals 84 power and 51 neutral of the control panel. For normally open contacts, wire between 82 & 81. For normally closed contacts, wire between 83 & 81. The alarm is operator programmable. The maximum rating of the alarm relay coil is 25 VA.
5. Remote on/off control of unit can be accomplished by installing a set of dry contacts between terminals 70 and 54.
6. Evaporator and condenser paddle type flow switches or water pressure differential switches are required and must be wired as shown. If field supplied pressure differential switches are used then these must be installed across the vessel and not the pump. Factory-mounted thermal dispersion flow sensors are available as an option.
7. Customer supplied 115 Vac, 20 amp power for optional evaporator and condenser water pump control power and tower fans is supplied to unit control terminals (UTBI) 85 power / 86 neutral, PE equipment ground.
8. Optional customer supplied 115 Vac, 25 VA maximum coil rated chilled water pump relay (EP 1 & 2) can be wired as shown. This option will cycle the chilled water pump in response to building load.
9. The condenser water pump must cycle with the unit. A customer supplied 115 Vac 25 VA maximum coil rated condenser water pump relay (CP1 & 2) is to be wired as shown.
10. Optional customer supplied 115 Vac, 25 VA maximum coil rated cooling tower fan relays (CL - C4) can be wired as shown. This option will cycle the cooling tower fans in order to maintain unit head pressure.
11. Auxiliary 24 Vac rated contacts in both the chilled water and condenser water pump starters must be wired as shown.
12. For VFD, Wye-Delta, and solid state starters connected to six (6) terminal motors. The conductors between the starter and motor carry phase current and selection shall be based on 58 percent of the motor rated load amperes (RLA). Wiring of free-standing starter must be in accordance with the NEC and connection to the compressor motor terminals shall be made with copper wire and copper lugs only. Main power wiring between the starter and motor terminals is factory-installed when chillers are supplied with unit-mounted starters.
13. Optional Open Choices BAS interfaces. The locations and interconnection requirements for the various standard protocols are found in their respective installation manuals, obtainable from the local Daikin sales office and also shipped with each unit:

Modbus IM 743	LonWorks IM 735	BACnet IM 906
---------------	-----------------	---------------
14. The “Full Metering” or “Amps Only Metering” option will require some field wiring when free-standing starters are used. Wiring will depend on chiller and starter type. Consult the local Daikin sales office for information on specific selections.

Figure 19, Field Control Wiring Diagram

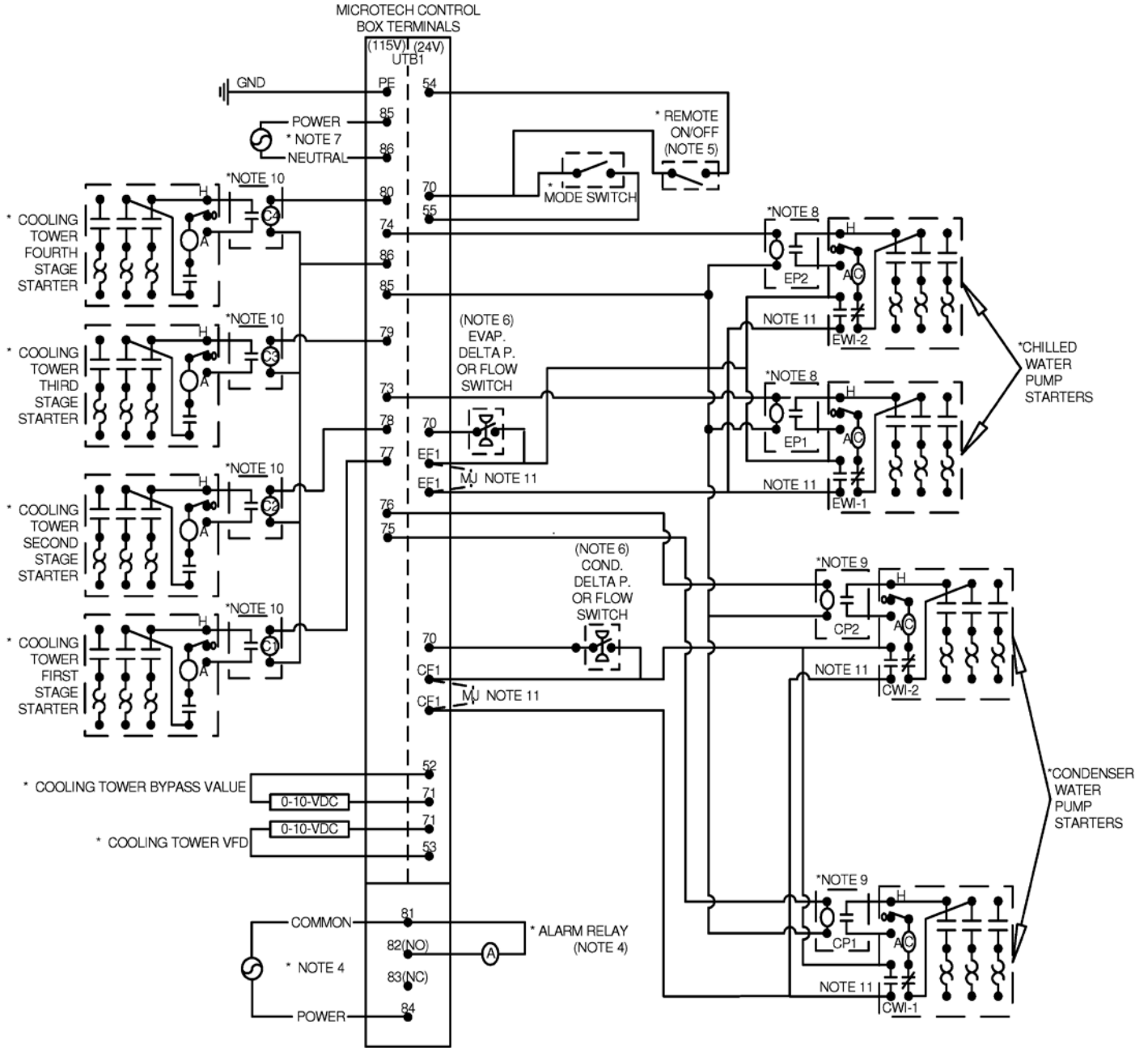
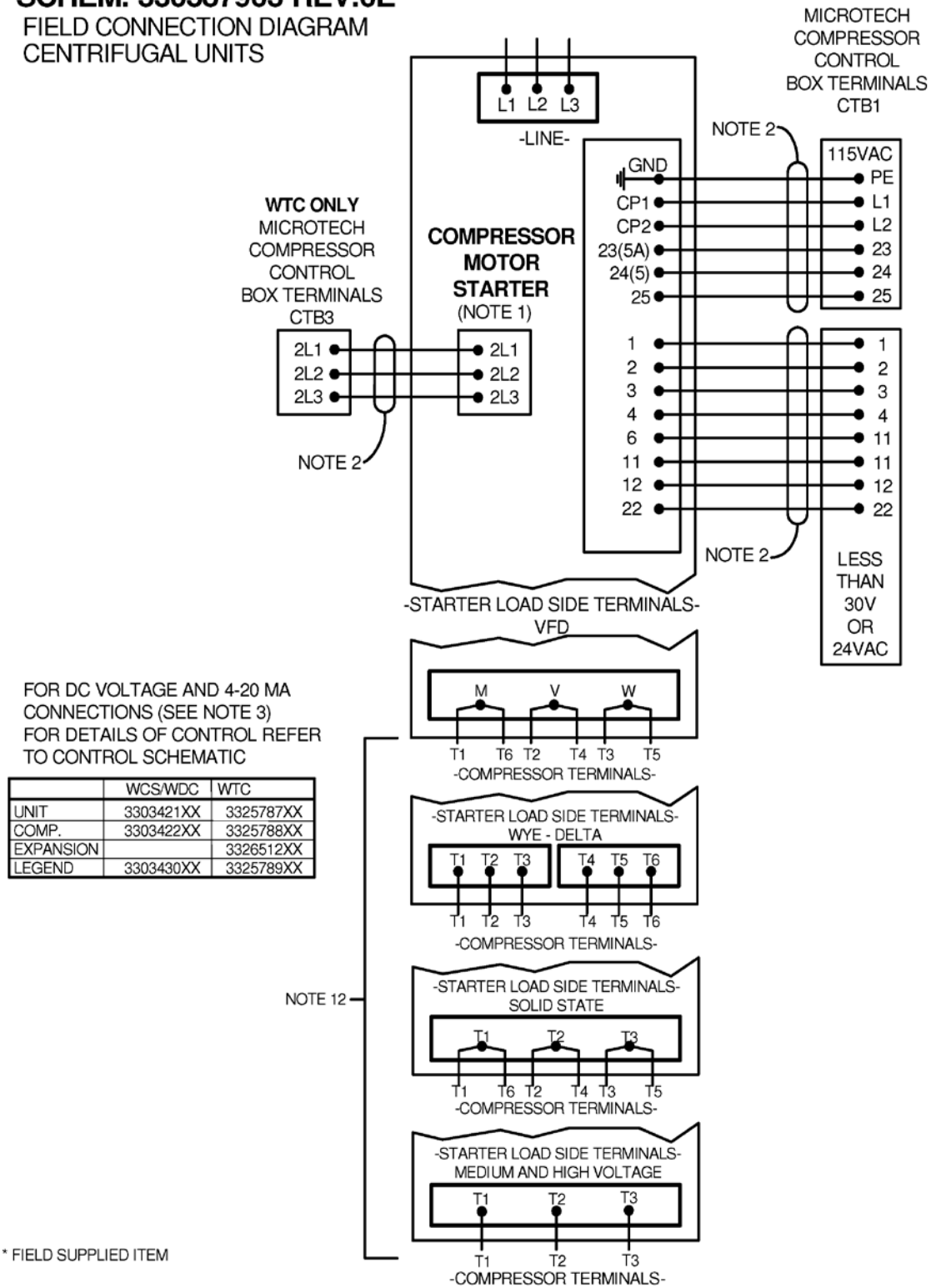

Figure 20, Field Wiring, Remote Starter

SCHEM. 330387903 REV.0E
 FIELD CONNECTION DIAGRAM
 CENTRIFUGAL UNITS



Multiple Chiller Setup

Single compressor chillers WSC and dual compressor chillers WDC and WCC have their main control components factory wired to an internal pLAN network so that the components can communicate with each other, within the chiller itself. On multi-chiller applications, up to four chillers, either single, or dual compressor, can be interconnected by this internal pLAN. All that is required is simple field RS485 interconnecting wiring, the addition of accessory communication isolation board(s) 485OPDR (Daikin P/N 330276202), and some MicroTech II control settings (see special WCC instructions at the end of this section). The 485OPDR isolation board can be purchased with the unit or separately, during or after chiller installation. The number of boards required equals the number of chillers minus one.

Note: pLAN multiple chiller interconnection is designed for parallel chiller installations with the leaving water sensors in their normal location in the outlet nozzle.

For two units in series operation, the leaving chilled water sensors must be moved far enough downstream from the last chiller to insure reading a thoroughly mixed water temperature. Passing through one or two elbows will usually suffice. Series chillers are normally single pass resulting in undesirable temperature stratification at the outlet nozzle.

Interconnectability

Centrifugal models WSC and WDC of various vintages with MicroTech II controllers can be interconnected but all must be loaded with the most recent control software.

Responsibilities

Unless otherwise stated in the contract documents, the interconnecting MicroTech II pLAN RS485 multiple chiller wiring between chillers is the responsibility of the installing contractor and should be completed prior to startup.

The Daikin startup technician is responsible to check the wiring and make the appropriate control changes.

pLAN Wiring

Connect chillers together (pLAN, RS485 wiring) as shown in Figure 21 on the following page. The first chiller in the connection can be designated as Chiller A. The isolation board is attached to the DIN rail adjacent to the Chiller A unit controller. The isolation board has a pigtail that is plugged into J10 on the controller. Most chillers will already have a universal communication module (UCM) that connects the controller to the touchscreen already plugged onto J10. If this is the case, plug the isolation module pigtail into the empty RJ11 pLAN port on the UCM. This is equivalent to plugging into the unit controller directly.

Next, interconnecting wiring is needed between Chiller A and Chiller B.

Two Chillers: If only two chillers are to be connected, Belden M9841 (RS 485 Spec Cable) is wired from the 485OPDR isolation board (terminals A, B, and C) on Chiller A to the J11 port on the unit controller of Chiller B. At J11, the shield connects to GND, the blue/white wire to the (+) connection, and the white/blue to the (-) connection. Note that Chiller B does not have an isolation board. The last chiller (B in this case) to be connected does not need an isolation board.

Three or Four Chillers: If three or more chillers are to be connected, the interconnecting wiring is still made to Chiller B's J11 port. The second chiller (Chiller B) must have a 485OPDR isolator board that will be plugged into Chiller B's UCM pLAN port. Chiller B will look like Chiller A.

The wiring from Chiller B to Chiller C will be the same as A to B. That is, Belden cable connects from A, B, and C on B's 485OPDR board to chiller C's L11 port. Chiller C has no 485OPDR isolation board.

The procedure is repeated to the fourth chiller if four chillers are interconnected.

Sequencing

The Daikin technician can set up different strategies for starting and stopping networked compressors, chillers, and pumps depending on site requirements.

Figure 21, Communication Wiring

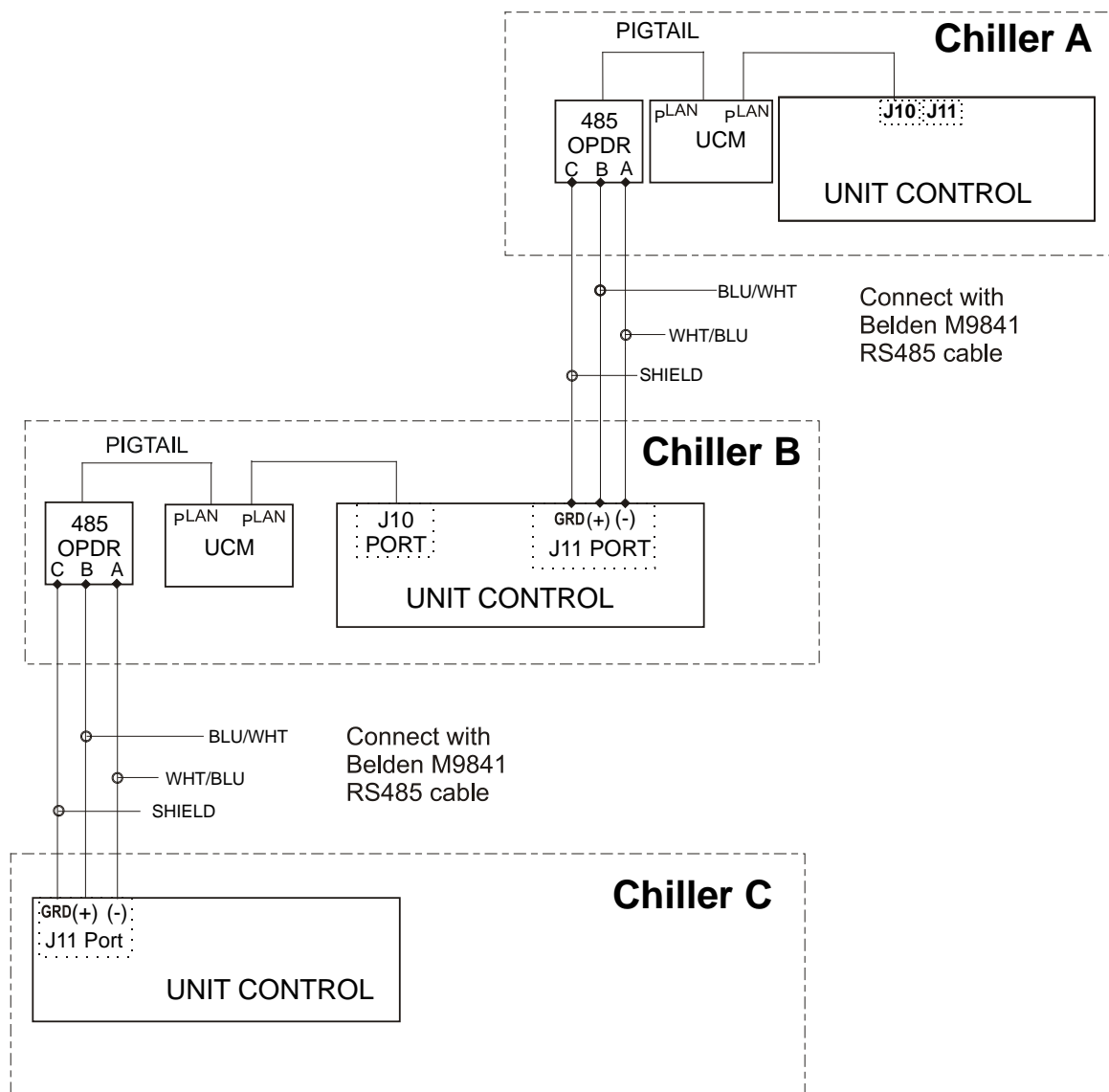

NOTE: A fourth chiller, Chiller D would be connected to chiller C same as chiller C to chiller B.

MicroTech II Operator Interface Touch Screen (OITS) Settings

Settings for any type of linked multiple compressor operation must be made to the MicroTech II controller. Settings on a dual compressor unit are made in the factory prior to shipment, but must be verified in the field before startup. Settings for multiple chiller installations are set in the field on the Operator Interface Touch Screen as follows:

Maximum Compressors ON – SETPOINTS - MODES screen, Selection #10 = 2 for a dual, 4 for 2 duals, 3 for three separate, single compressor chillers, etc. If all compressors in the system are to be available as normal running compressors, then the value entered in #10 should equal the total number of compressors. If any compressors are for standby and not operated in normal rotation, they should not be included in the compressor count in Selection #10. The Max Comp ON setting can be made in only one touchscreen, the system will observe the highest number set on all chillers-it is a global setting.

Sequence and Staging – SETPOINTS - MODES screen, Selection #12 & #14; #11 & #13. Sequence sets the sequence in which compressors will start. Setting one or more compressors to “1” evokes the automatic lead/lag feature and is the normal setting. The compressor with least starts will start first and the compressor with maximum hours will stop first, and so on. Units with higher numbers will stage on in sequence.

The Modes setpoints will do several different types of operation (Normal, Efficiency, Standby, etc.) as described in the operating manual.

The same Modes setting must be replicated on each chiller in the system.

Nominal Capacity – SETPOINTS - MOTOR screen, Selection #14. The setting is the compressor design tons. Compressors on dual units are always of equal capacity.

WCC Settings

Since the WCC is essentially two chillers combined into one counterflow, single pass, dual-circuit chiller, the compressor on the downstream circuit (leaving chilled water) must always be designated as the Stage 1 compressor-first on, last off.

Operating Sequence

For multiple-chiller, parallel operation, the MicroTech II controllers are tied together by a pLAN network and stage and control compressor loading among the chillers. Each compressor, single or dual compressor chiller, will stage on or off depending on the sequence number programmed into it. For example, if all are set to “1”, the automatic lead/lag will be in effect.

When chiller #1 is fully loaded, the leaving chilled water temperature will rise slightly. When the Delta-T above setpoint reaches the Staging Delta-T, the next chiller scheduled to start will receive a start signal and start its pumps if they are set up to be controlled by the Microtech controller. This procedure is repeated until all chillers are running. The compressors will load-balance themselves.

If any of the chillers in the group are dual compressor, they will stage and load according to the staging instructions.

See *OM 1153* (current revision) for a complete description of the various staging sequences available.

Prestart System Checklist

	Yes	No	N/A
Chilled Water			
Piping complete.....	<input type="checkbox"/>	<input type="checkbox"/>	<input type="checkbox"/>
Water system filled, vented	<input type="checkbox"/>	<input type="checkbox"/>	<input type="checkbox"/>
Pumps installed, (rotation checked), strainers cleaned.....	<input type="checkbox"/>	<input type="checkbox"/>	<input type="checkbox"/>
Strainer installed at evaporator inlet	<input type="checkbox"/>	<input type="checkbox"/>	<input type="checkbox"/>
Controls (3-way, face and bypass dampers, bypass valves, etc.) operable.....	<input type="checkbox"/>	<input type="checkbox"/>	<input type="checkbox"/>
Water system operated and flow balanced to meet unit design requirements	<input type="checkbox"/>	<input type="checkbox"/>	<input type="checkbox"/>
Condenser Water (*)			
Cooling tower flushed, filled and vented	<input type="checkbox"/>	<input type="checkbox"/>	<input type="checkbox"/>
Pumps installed, (rotation checked), strainers cleaned	<input type="checkbox"/>	<input type="checkbox"/>	<input type="checkbox"/>
Strainer installed at condenser inlet	<input type="checkbox"/>	<input type="checkbox"/>	<input type="checkbox"/>
Controls (3-way, bypass valves, etc.) operable	<input type="checkbox"/>	<input type="checkbox"/>	<input type="checkbox"/>
Water system operated and flow balanced to meet unit requirements	<input type="checkbox"/>	<input type="checkbox"/>	<input type="checkbox"/>
Electrical			
115-volt service completed, but not connected to control panel	<input type="checkbox"/>	<input type="checkbox"/>	<input type="checkbox"/>
Power leads connected to starter; load leads run to compressor ready for connection when service engineer is on hand for start-up	<input type="checkbox"/>	<input type="checkbox"/>	<input type="checkbox"/>
(Do not connect starter or compressor terminals)			
All interlock wiring complete between control panel and complies with specifications ..	<input type="checkbox"/>	<input type="checkbox"/>	<input type="checkbox"/>
Starter complies with specifications	<input type="checkbox"/>	<input type="checkbox"/>	<input type="checkbox"/>
Pump starters and interlock wired	<input type="checkbox"/>	<input type="checkbox"/>	<input type="checkbox"/>
Cooling tower fans and controls wired	<input type="checkbox"/>	<input type="checkbox"/>	<input type="checkbox"/>
Wiring complies with National Electrical Code and local codes	<input type="checkbox"/>	<input type="checkbox"/>	<input type="checkbox"/>
Condenser pump starting relay (CWR) installed and wired	<input type="checkbox"/>	<input type="checkbox"/>	<input type="checkbox"/>
Miscellaneous			
Oil cooler water piping complete (units with water cooled oil coolers only)	<input type="checkbox"/>	<input type="checkbox"/>	<input type="checkbox"/>
Relief valve piping complete	<input type="checkbox"/>	<input type="checkbox"/>	<input type="checkbox"/>
Thermometer wells, thermometers, gauges, control wells, controls, etc., installed	<input type="checkbox"/>	<input type="checkbox"/>	<input type="checkbox"/>
Minimum system load of 80% of machine capacity available for testing and adjusting controls	<input type="checkbox"/>	<input type="checkbox"/>	<input type="checkbox"/>

(*) Includes heating hot water on heat recovery units.

Note: This checklist must be completed and sent to the local Daikin service location two weeks prior to start-up.

Commissioning

This brief section on unit operation is included to assist in commissioning. Complete operating information is contained in Daikin manual OM 1153.

During the initial startup of the chiller the Daikin technician will be available to answer any questions and instruct in the proper operating procedures.

It is recommended that the operator maintain an operating log for each individual chiller unit. In addition, a separate maintenance log should be kept of the periodic maintenance and servicing activities.

This Daikin centrifugal chiller represents a substantial investment and deserves the attention and care normally given to keep this equipment in good working order. If the operator encounters abnormal or unusual operating conditions, it is recommended that a Daikin service technician be consulted.

Daikin conducts training for centrifugal operators at its factory Training Center in Staunton, Virginia, several times a year. These sessions are structured to provide basic classroom instruction and include hands-on operating and troubleshooting exercises. For further information, contact your Daikin representative.

Standby Power

It is essential that any centrifugal chiller connected to standby power come to a complete stop before being restarted on grid power. This is usually not an issue when running on grid power and experiencing a grid power failure since the chiller's control will shut down the chiller and disconnect it from the power source for the stop-to-start setpoint time. It will have come to a complete stop before restarting.

Attempting to switch back and forth from regular grid line power and auxiliary power while the compressor is running can result in extreme transient torque that will severely damage the compressor.

MicroTech II™ Control

Figure 22, MicroTech II Control Panel



All chillers are equipped with the Daikin MicroTech II control system consisting of:

- Operator touchscreen interface panel (shown at the left). It consists of a 15-inch Super VGA color screen and a floppy drive. See Figure 22.
- Unit Control Panel containing the MicroTech II unit controller and miscellaneous switches and field connection terminals.
- Compressor Control Panel for each compressor containing the MicroTech II compressor controller and lube system control components.

NOTE: Detailed information on the operation of the MicroTech II control is contained in the *OM 1153* available on www.DaikinApplied.com.

Figure 23, Unit Control Panel

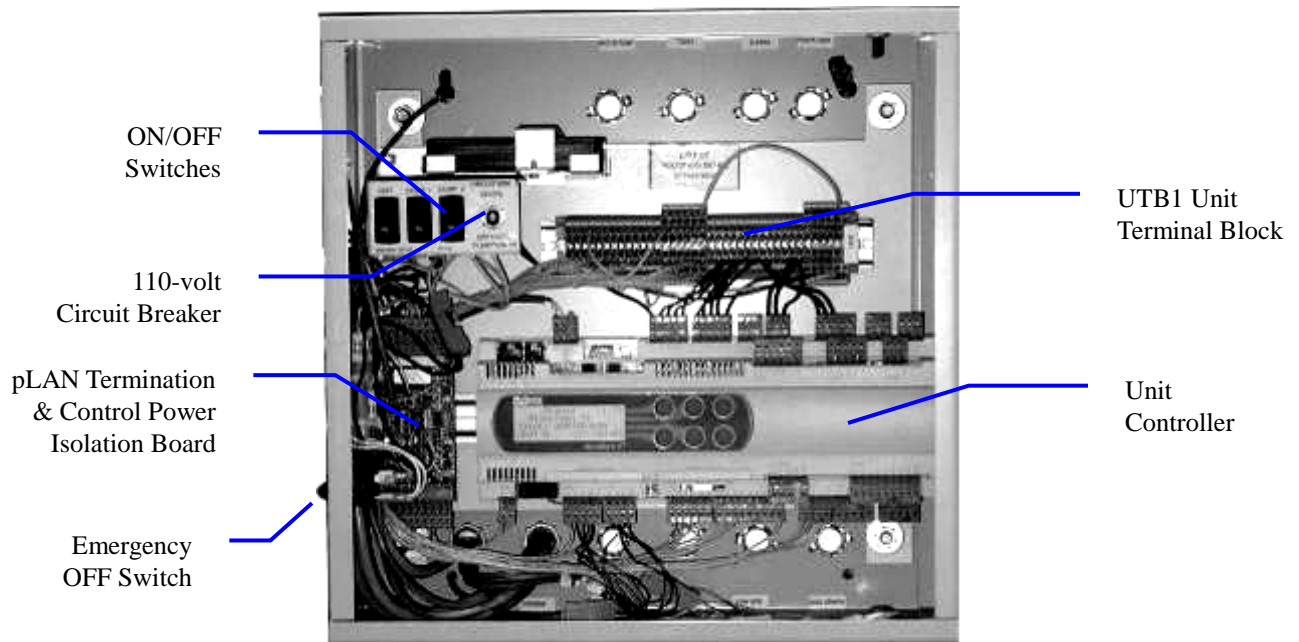
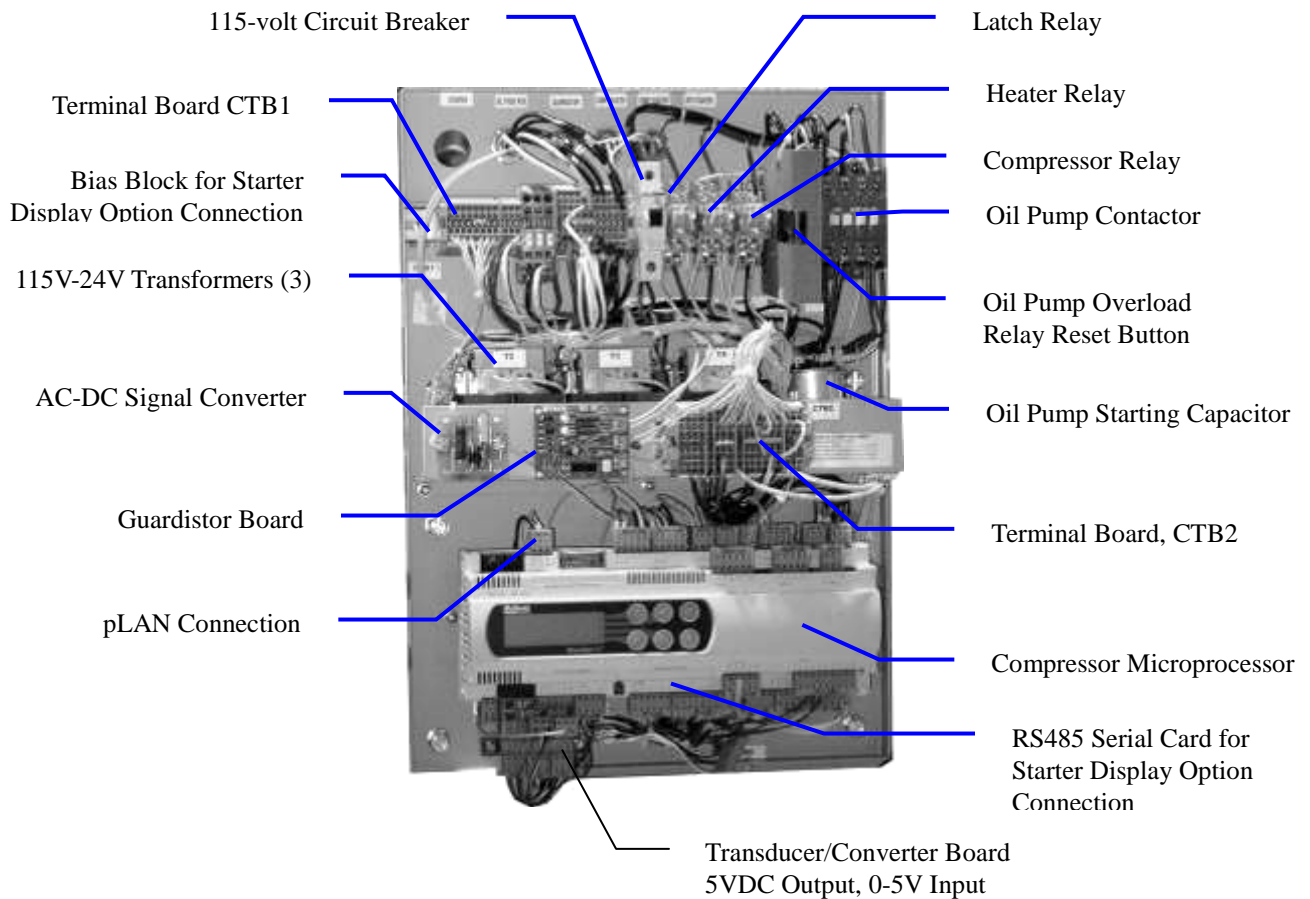

Figure 24, Compressor Control Panel



Capacity Control System

The opening or closing of the inlet vanes controls the quantity of refrigerant entering the impeller thereby controlling the compressor capacity. The vane movement occurs in response to oil flow from the SA or SB 4-way solenoid valves, which in turn, respond to instructions from the unit microprocessor as it senses leaving chilled water temperature. This oil flow activates a sliding piston that rotates the vanes.

Vane Operation

The hydraulic system for the inlet guide vane capacity control operation consists of a 4-way normally open solenoid valve located in the oil management control panel or on the compressor close to the suction connection. Oil under pressure from the oil filter is directed by the 4-way valve to either or both sides of the piston, depending on whether the control signal is to load, unload, or hold.

To open the vanes (loading compressor), solenoid SA is de-energized and SB is energized, allowing oil flow from port SA to one side of the piston. The other side drains through port SB.

To close the vanes (unload compressor), valve SB is de-energized and valve SA is energized to move the piston and vanes toward the unload position.

When both solenoid valves SA and SB are de-energized, full oil pressure is directed to both sides of the piston through ports SA and SB, and the vanes are held in that position. Refer to Figure 27 and Figure 28 for solenoid action. Note that both solenoids cannot be *energized* simultaneously.

Vane Speed Metering Valves

The speed at which the capacity control vanes are opened or closed can be adjusted to suit system operating requirements. Adjustable needle valves in the oil drain lines are used to control the rate of bleed-off and consequently the “vane speed”. These needle valves are part of the 4-way solenoid valve assembly located in the compressor lube box (Figure 26).

The valves are normally factory set so that the vanes will move from fully closed to fully opened in the time periods shown in Table 14 on page 40.

The speed must be slow enough to prevent over-controlling and hunting. The left adjusting screw is the SB needle valve for adjusting the vane OPENING speed for loading the compressor. Turn this screw clockwise to decrease the vane opening speed and counterclockwise to increase the opening speed.

The right adjusting screw is the SA needle valve for adjusting the CLOSING speed to unload the compressor. The same adjustment method applies; clockwise to decrease closing, counterclockwise to increase vane closing. These adjustments are sensitive. Turn the adjusting screws a few degrees at a time. The vane speed is factory set and varies by compressor size.

The start-up technician may readjust the vane speed at initial start-up to meet job conditions.

Figure 25, Needle Valve Location

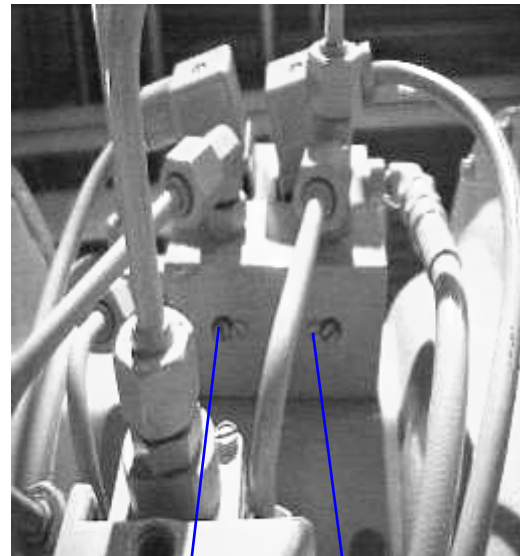

Open (Load) Close (Unload)

Table 14, Vane Speed Factory Setting

Compressor Model	Opening Time	Closing Time
CE063 - CE100	3 - 5 min.	1 - 2 min
CE126	5 - 8 min.	1 - 2 min.

Figure 26, Oil Sump and Compressor Controller Panel

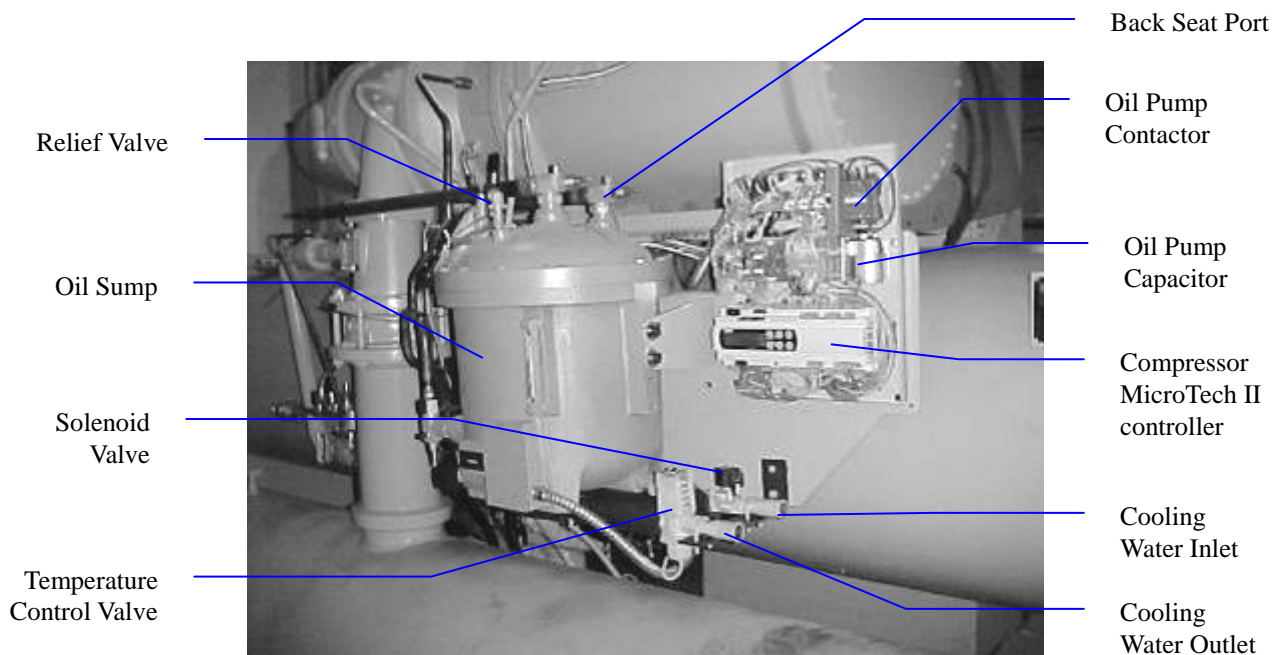

NOTE: 4-way solenoid valve and vane close switches are located on the compressor suction inlet. The mechanical high-pressure cutout is located in the discharge line.

Figure 27, Vane Control Solenoid Operation

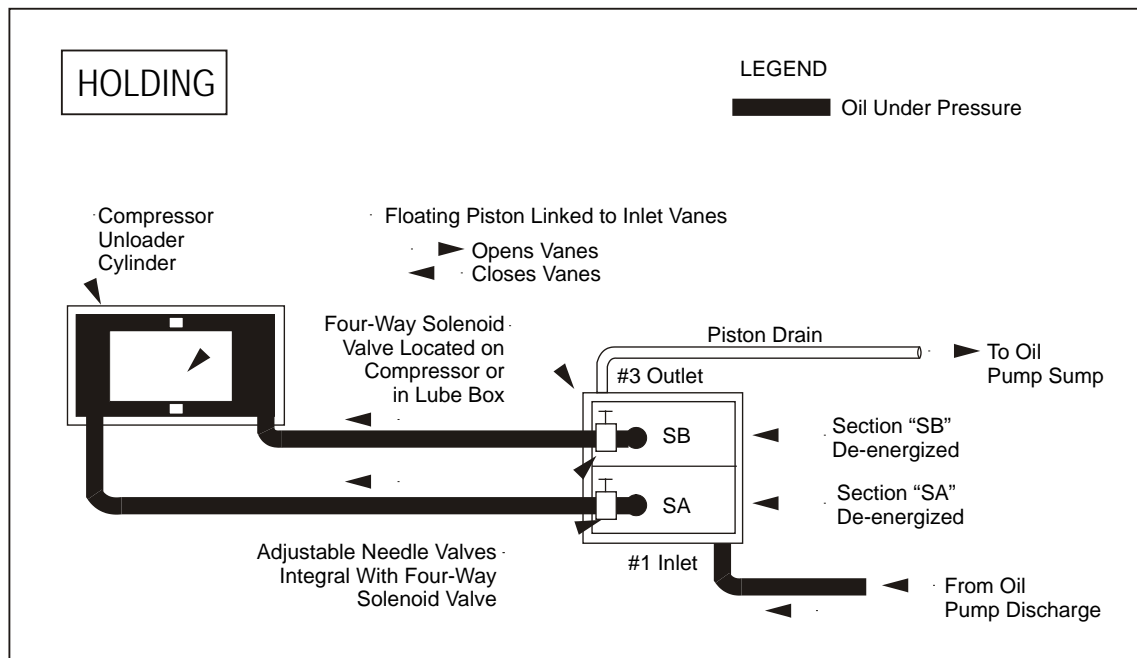
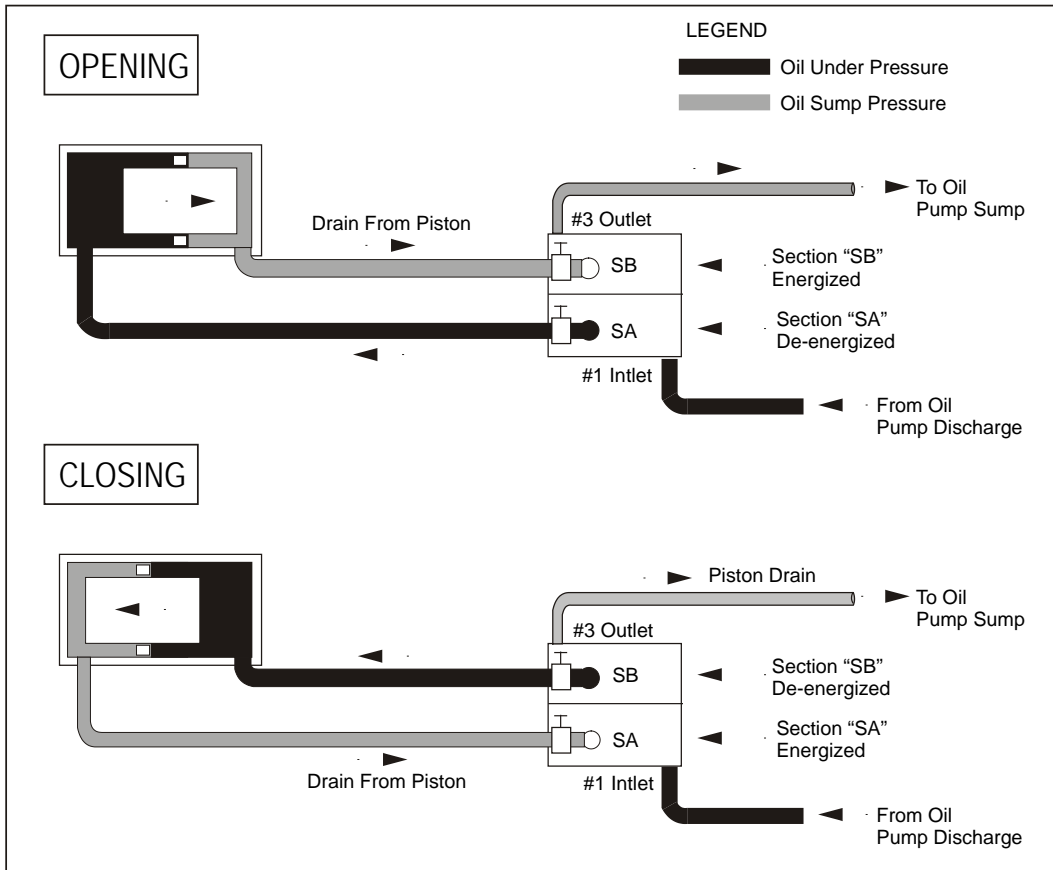

Figure 28, Vane Control Solenoid Operation, Continued



Surge and Stall

Stall and surge are a characteristic of all centrifugal compressors. These conditions occur when low load combines with high compressor lift. In a stall, discharge gas has insufficient velocity leaving the impeller to reach the volute and just "sits" or stalls in the diffuser section. The compressor sound level goes way down due to no flow and the impeller starts to heat up. In surge, the heated discharge gas alternately flows back through the impeller and then reverses to the volute about every two seconds. Extreme noise and vibration occur. The compressor is equipped with a temperature sensor that shuts it off if these conditions occur.

Lubrication System

The lubrication system provides lubrication and heat removal for compressor bearings and internal parts. In addition, the system provides lubricant under pressure to hydraulically operate the unloading piston for positioning the inlet guide vanes for capacity control. WDC, dual compressor chillers, have completely independent lubrication systems for each compressor.

Only the recommended lubricant, as shown in Table 15, can be used for proper operation of the hydraulic system and bearing lubrication system. Each unit is factory-charged with the correct amount of the recommended lubricant. Under normal operation, no additional lubricant is needed. Lubricant must be visible in the sump sight glass at all times.

Compressor sizes, CE063 through CE126, utilize a separate lubricant pump located in the sump. The sump includes the pump, motor, heater and lubricant/vapor separator system. The lubricant is pumped through the external oil cooler and then to the oil filter located inside the compressor housing. WSC/WDC/WCC 063-126 units, single or dual compressor, all utilize a water-cooled oil cooler for each compressor.

The oil coolers maintain the proper oil temperature under normal operating conditions. The coolant flow control valve maintains 95°F to 105°F (35°C to 41°C). Lubrication protection for coast down in the event of a power failure is accomplished by a spring-loaded piston in models CE063 through 100. When the oil pump is started, the

piston is forced back against the spring by the oil pressure, compressing the spring, and filling the piston cavity with oil. When the pump stops, the spring pressure on the piston forces the oil back out to the bearings.

In compressor model CE126 the compressor coast down lubrication is supplied from a gravity-feed oil reservoir.

A typical flow diagram is shown in Figure 29.

Table 15, Approved Polyolester Oils For R-134a Units

Compressor Models	CE063 - 126
Lubricant Designation	Mobil Artic EAL 46; ICI Emkarate RL32H ⁽²⁾
Daikin Part Number	
55 Gal. Drum	735030432, Rev 47
5 Gal. Drum	735030433, Rev 47
1 Gal. Can	735030435, Rev 47
Compressor Oil Label	070200106, Rev OB

NOTES:

1. Approved oil from two suppliers can be mixed, although they have slightly different viscosity.
2. Lubricant from either supplier can be furnished when ordering by Daikin part number.

⚠ WARNING

This unit contains POE lubricants that must be handled carefully and the proper protective equipment (gloves, eye protection, etc.) must be used when handling POE lubricant. POE must not come into contact with any surface or material that might be harmed by POE, including certain polymers (e.g. PVC/CPVC and polycarbonate piping).

Figure 29, Typical Oil Flow Diagram

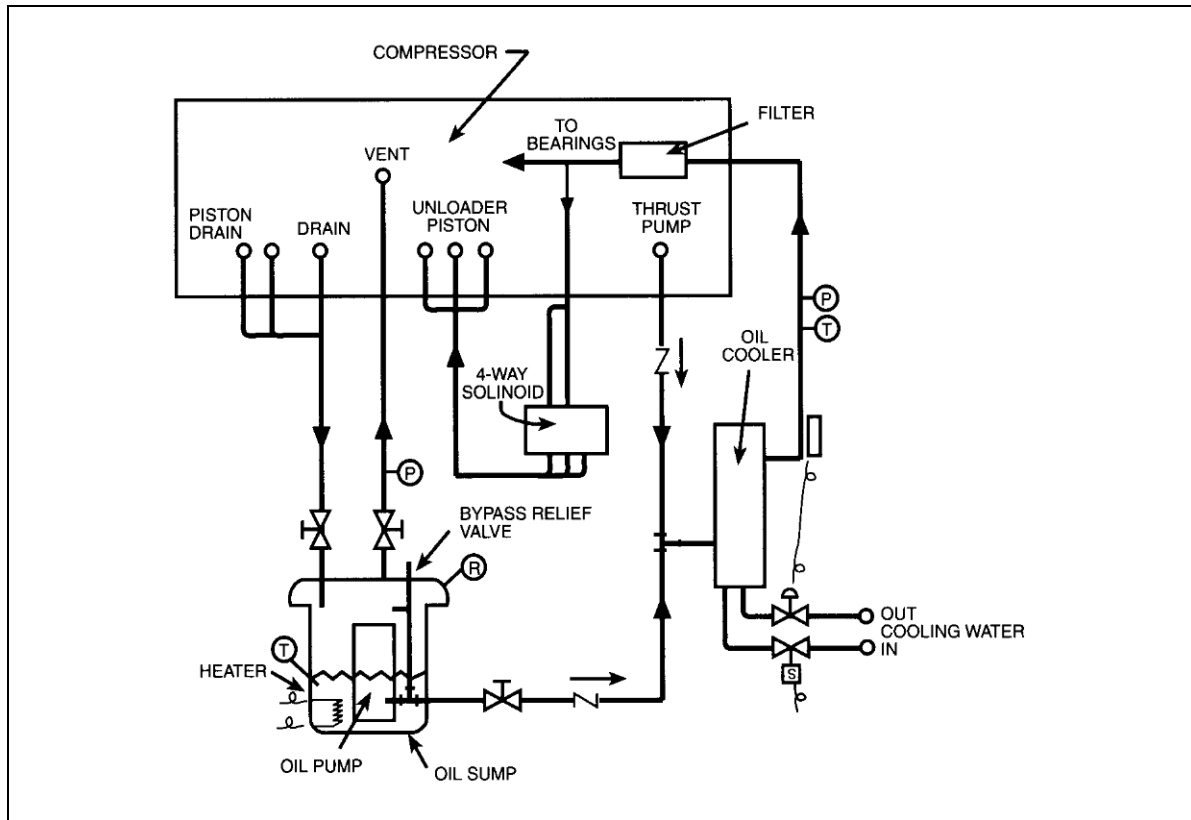

NOTES:

1. Connections are not necessarily in correct relative location.
2. R = relief valve, P = pressure sensor, T = temperature sensor, S = solenoid valve

Hot Gas Bypass

All units can be equipped with an optional hot gas bypass system that feeds discharge gas directly into the evaporator when the system load falls below 10% compressor capacity.

Light load conditions are signaled by measurement of the percentage of RLA amps by the MicroTech II controller. When the RLA drops to the setpoint, the hot gas bypass solenoid valve is energized, making hot gas bypass available for metering by the hot gas regulating valve. This hot gas provides a stable refrigerant flow and keeps the chiller from short cycling under light load conditions. It also reduces surge potential on heat recovery units.

The factory setpoint for bringing on hot gas bypass is 40% of RLA.

Condenser Water Temperature

When the ambient wet bulb temperature is lower than design, the entering condenser water temperature can be allowed to fall, improving chiller performance. See page 7 for details.

Daikin chillers will *start* with entering condenser water temperature as low as 55°F (42.8°C) providing the chilled water temperature is below the condenser water temperature.

The minimum *operating* entering condenser water temperature is a function of the leaving chilled water temperature and load.

Even with tower fan control, some form of water flow control such as tower bypass must be used.

Maintenance

Pressure/Temperature Chart

HFC-134a Temperature Pressure Chart							
°F	PSIG	°F	PSIG	°F	PSIG	°F	PSIG
6	9.7	46	41.1	86	97.0	126	187.3
8	10.8	48	43.2	88	100.6	128	192.9
10	12.0	50	45.4	90	104.3	130	198.7
12	13.2	52	47.7	92	108.1	132	204.5
14	14.4	54	50.0	94	112.0	134	210.5
16	15.7	56	52.4	96	115.9	136	216.6
18	17.1	58	54.9	98	120.0	138	222.8
20	18.4	60	57.4	100	124.1	140	229.2
22	19.9	62	60.0	102	128.4	142	235.6
24	21.3	64	62.7	104	132.7	144	242.2
26	22.9	66	65.4	106	137.2	146	249.0
28	24.5	68	68.2	108	141.7	148	255.8
30	26.1	70	71.1	110	146.3	150	262.8
32	27.8	72	74.0	112	151.1	152	270.0
34	29.5	74	77.1	114	155.9	154	277.3
36	31.3	76	80.2	116	160.9	156	284.7
38	33.1	78	83.4	118	166.0	158	292.2
40	35.0	80	86.7	120	171.1	160	299.9
42	37.0	82	90.0	122	176.4	162	307.8
44	39.0	84	93.5	124	181.8	164	315.8

Routine Maintenance

Lubrication



CAUTION

Improper servicing of the lubrication system, including the addition of excessive or incorrect oil, substitute quality oil filter, or any mishandling can damage the equipment. Only authorized and trained service personnel should attempt this service. For qualified assistance, contact your local Daikin service location.

After the system is once placed into operation, no other additional oil is required except in the event that repair work becomes necessary to the oil pump, or unless a large amount of oil is lost from the system due to a leak.

If oil must be added with the system under pressure, use a hand pump with its discharge line connected to the backseat port of the valve in the lubricant drain from the compressor to the sump. See Figure 26 on page 40. The POE oils used with R-134a are hygroscopic and care must be exercised to avoid exposure to moisture (air).

The condition of compressor oil can be an indication of the general condition of the refrigerant circuit and compressor wear. An annual oil check by a qualified laboratory is essential for maintaining a high level of maintenance. It is useful to have an oil analysis at initial startup to provide a benchmark from which to compare future tests. The local Daikin service office can recommend suitable facilities for performing these tests.

Table 16 gives the upper limits for metals and moisture in the polyolester lubricants required by Daikin chillers.

Table 16, Metal and Moisture Limits

Element	Upper Limit (PPM)	Action
Aluminum	50	1
Copper	100	1
Iron	100	1
Moisture	400	2
Silica	50	1
Total Acid Number (TAN)	0.19	3

Key to Action

- 1) Re-sample after 500 hours of unit operation.
 - a) If content increases less than 10%, change oil and oil filter and re-sample at normal interval (usually annual).
 - b) If content increases between 11% and 24%, change oil and oil filter and re-sample after an additional 500 hours of operation.
 - c) If content increases more than 25%, inspect compressor for cause.
- 2) Re-sample after 500 hours of unit operation.
 - a) If content increases less than 10%, change filter-drier and re-sample at normal interval (usually annual).
 - b) If content increases between 11% and 24%, change filter-drier and re-sample after an additional 500 hours of operation.
 - c) If content increases more than 25%, monitor for a water leak.
- 3) If TAN is less than 0.10, system is safe as far as acid is concerned.
 - a) For TAN between 0.10 and 0.19, re-sample after 1000 hours of operation.
 - b) For TAN above 0.19, change oil, oil filter, and filter-drier and resample at normal interval

Changing Oil Filters

Daikin chillers are at positive pressure at all times and do not leak contaminated moist air into the refrigerant circuit, thereby eliminating the need for annual oil changes. An annual laboratory oil check is recommended to check overall compressor condition.

The oil filter can be changed by simply isolating the filter cavities. Close the oil discharge line service valve at the oil pump (at the filter on CE126). Remove the filter cover; some foaming can occur but the check valve should limit leakage from other compressor cavities. Remove the filter, replace with new element, and replace filter cover using a new gasket. Reopen the valve in the pump discharge line and purge air from the oil filter cavity.

When machine is operated again, the oil level must be checked to determine if oil needs to be added to maintain the proper operating level.

Refrigerant Cycle

Maintenance of the refrigerant cycle includes maintaining a log of the operating conditions, and checking that the unit has the proper oil and refrigerant charge.

At every inspection, the oil, suction, and discharge pressures should be noted and recorded, as well as condenser and chiller water temperatures.

The suction line temperature at the compressor should be taken at least once a month. Subtracting the saturated temperature equivalent of the suction pressure from this will give the suction superheat. Extreme changes in subcooling and/or superheat over a period of time will indicate losses of refrigerant or possible deterioration or malfunction of the expansion valves. Proper superheat setting is 0 to 1 degree F (0.5 degree C) at full load. Such a small temperature difference can be difficult to measure accurately. Another method is to measure the compressor discharge superheat, the difference between the actual discharge temperature and the saturated discharge temperature. The discharge superheat should be between 14 and 16 degrees F (8 to 9 degrees C) at full load. The liquid injection must be deactivated (by closing the valve in the feed line) when taking the discharge temperature. The superheat will increase linearly to 55 degrees F (30 degrees C) at 10% load. The MicroTech II interface panel can display all superheat and subcooling temperatures.

Figure 8. Typical Refrigerant Flow Diagram

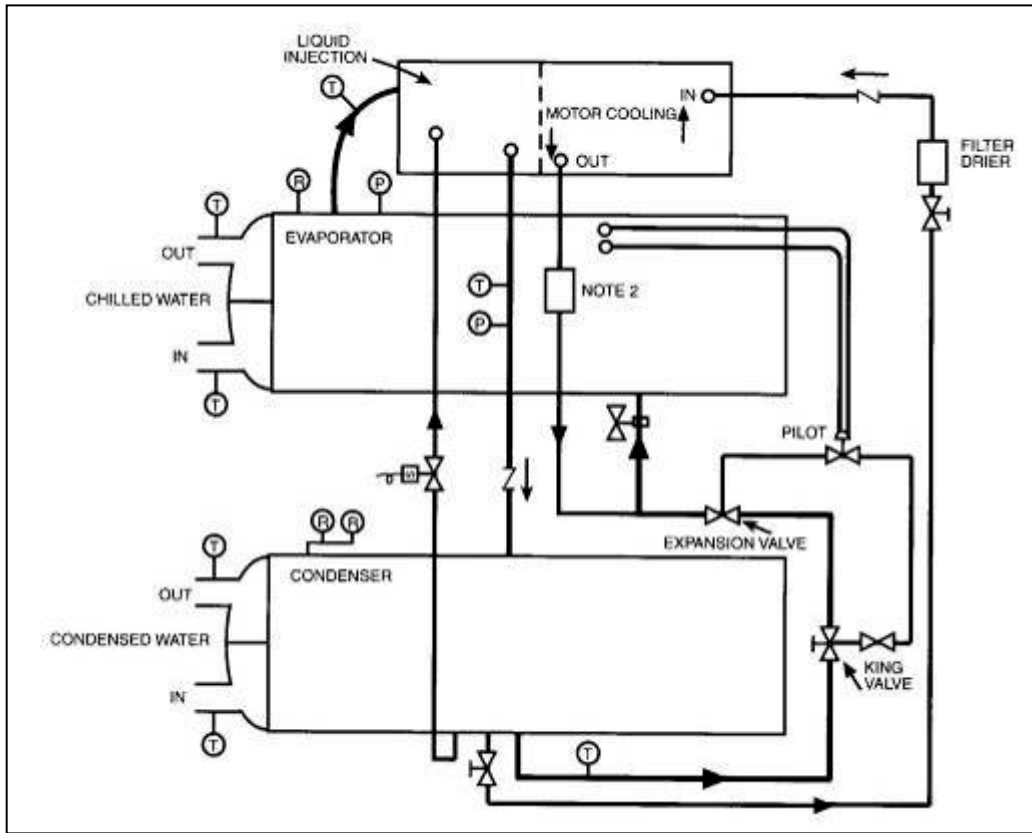

1. Connections are not necessarily in correct relative location.
2. Filter is for burnout protection of the refrigerant.

Electrical System

Maintenance of the electrical system involves the general requirement of keeping contacts clean and connections tight and checking on specific items as follows:

1. The compressor current draw should be checked and compared to nameplate RLA value. Normally, the actual current will be lower, since the nameplate rating represents full load operation. Also check all pump and fan motor amperages, and compare with nameplate ratings.
2. Inspection must verify that the oil heaters are operative. The heaters are insert-cartridge type and can be checked by ammeter reading. They should be energized whenever power is available to the control circuit, when the oil temperature sensor calls for heat, and when the compressor is inoperative. When the compressor runs, the heaters are de-energized. The Digital Output screen and second View screen on the operator interface panel both indicate when the heaters are energized.
3. At least once a quarter, all equipment protection controls except compressor overloads should be made to operate and their operating points checked. A control can shift its operating point as it ages, and this must be detected so the controls can be adjusted or replaced. Pump interlocks and flow switches should be checked to be sure they interrupt the control circuit when tripped.
4. The contactors in the motor starter should be inspected and cleaned quarterly. Tighten all terminal connections.
5. The compressor motor resistance to ground should be checked and logged semi-annually. This log will track insulation deterioration. A reading of 50 megohms or less indicates a possible insulation defect or moisture and must be further checked.



CAUTION

Never Megger a motor while in a vacuum. Severe motor damage can result.

6. The centrifugal compressor must rotate in the direction indicated by the arrow on the rear motor cover plate, near the rotation sight glass. If the operator has any reason to suspect that the power system connections have been altered, (phases reversed) the compressor must be jogged to check rotation. For assistance, call the local Daikin service location.

Cleaning and Preserving

A common cause of service calls and equipment malfunction is dirt. This can be prevented with normal maintenance. The system components most subject to dirt are:

1. Permanent or cleanable filters in the air handling equipment must be cleaned in accordance with the manufacturer's instructions; throwaway filters should be replaced. The frequency of this service will vary with each installation.
2. Remove and clean strainers in chilled water system, oil cooler line and condenser water system at every inspection.
3. Inspect the condenser tubes annually for fouling and clean if required. The dished water heads (aka end-bells, water boxes) should be removed with care due to their weight. One method follows:
 - After draining water, remove all but four head bolts at roughly 10 and 2 o'clock and 4 and 8 o'clock.
 - Loosen the remaining four bolts to enable the head to be separated from the tube sheet sufficiently for a clevis pin or hook to be inserted into an open bolt hole at the top of the head.
 - Attach a hoist to the pin or hook, lift the head to remove weight from the remaining bolts, remove the bolts and carefully remove the head.
 - Do not try to install an eyebolt with machine threads into the head vent fitting, which has pipe threads.
 - Reverse this procedure to mount the head, using a new gasket.

Annual Shutdown

Seasonal Servicing

Prior to shutdown periods and before starting up again, the following service procedures must be completed.

Where the chiller can be subject to freezing temperatures, the condenser and chiller must be drained of all water. Dry air blown through the condenser will aid in forcing all water out. Removal of condenser heads is also recommended. The condenser and evaporator are not self-draining and tubes must be blown out. Water permitted to remain in the piping and vessels can rupture these parts if subjected to freezing temperature.

Forced circulation of antifreeze through the water circuits is one method of avoiding freeze up.

1. Take measures to prevent the shutoff valve in the water supply line from being accidentally turned on.
2. If a cooling tower is used, and if the water pump will be exposed to freezing temperatures, be sure to remove the pump drain plug and leave it out so any water that can accumulate will drain away.
3. Open the compressor disconnect switch, and remove the fuses. **If the transformer is used for control voltage, the disconnect must remain on to provide power to the oil heater.** Set the manual UNIT ON/OFF switch in the Unit Control Panel to the OFF position.
4. Check for corrosion and clean and paint rusted surfaces.
5. Clean and flush water tower for all units operating on a water tower. Make sure tower blowdown or bleed-off is operating. Set up and use a good maintenance program to prevent "liming up" of both tower and condenser. It should be recognized that atmospheric air contains many contaminants that increase the need for proper water treatment. The use of untreated water can result in corrosion, erosion, sliming, scaling or algae formation. It is recommended that the service of a reliable water treatment company be used. Daikin assumes no responsibility for the results of untreated or improperly treated water.
6. Remove condenser heads at least once a year to inspect the condenser tubes and clean if required.

Annual Startup

A dangerous condition can exist if power is applied to a faulty compressor motor starter that has been burned out. This condition can exist without the knowledge of the person starting the equipment.

This is a good time to check all the motor winding resistance to ground. Semi-annual checking and recording of this resistance will provide a record of any deterioration of the winding insulation. All new units have well over 100 megohms resistance between any motor terminal and ground.

Whenever great discrepancies in readings occur, or uniform readings of less than 50 megohms are obtained, the motor cover must be removed for inspection of the winding prior to starting the unit. Uniform readings of less than 5 megohms indicate motor failure is imminent and the motor should be replaced or repaired. Repair before failure occurs can save a great deal of time and labor spent in the cleanup of a system after a motor burnout.

1. The control circuit must be energized at all times, except during service. If the control circuit has been off and oil is cool, energize oil heaters and allow 24 hours for heater to remove refrigerant from the oil before starting.
2. Check and tighten all electrical connections.
3. Replace the drain plug in the cooling tower pump if it was removed at shutdown time the previous season.
4. Install fuses in main disconnect switch (if removed).
5. Reconnect water lines and turn on supply water. Flush condenser and check for leaks.
6. Refer to Manual OM CentrifMicro II before energizing the compressor circuit.

Repair of System

Pressure Relief Valve Replacement

Current condenser designs use two relief valves separated by a three-way shutoff valve (one set). This three-way valve allows either relief valve to be shut off, but at no time can both be shut off. In the event one of the relief valves are leaking in the two valve set, these procedures must be followed:

- If the valve closest to the valve stem is leaking, back seat the three-way valve all the way, closing the port to the leaking pressure relief valve. Remove and replace the faulty relief valve. The three-way shutoff valve must remain either fully back seated or fully forward to normal operation. If the relief valve farthest from the valve stem is leaking, front seat the three-way valve and replace the relief valve as stated above.
- The refrigerant must be pumped down into the condenser before the evaporator relief valve can be removed.

Pumping Down

If it becomes necessary to pump the system down, extreme care must be used to avoid damage to the evaporator from freezing. Always make sure that full water flow is maintained through the chiller and condenser while pumping down. To pump the system down, close all liquid line valves. With all liquid line valves closed and water flowing, start the compressor. Set the MicroTech II control to the manual load. The vanes must be open while pumping down to avoid a surge or other damaging condition. Pump the unit down until the MicroTech II controller cuts out at approximately 20 psig. It is possible that the unit might experience a mild surge condition prior to cutout. If this should occur, immediately shut off the compressor. Use a portable condensing unit to complete the pump down, condense the refrigerant, and pump it into the condenser or pumpout vessel using approved procedures.

A pressure regulating valve must always be used on the drum being used to build the system pressure. Also, do not exceed the test pressure given above. When the test pressure is reached disconnect the gas cylinder.

Pressure Testing

No pressure testing is necessary unless some damage was incurred during shipment. Damage can be determined upon a visual inspection of the exterior piping, checking that no breakage occurred or fittings loosened. Service gauges should show a positive pressure. If no pressure is evident on the gauges, a leak may have occurred, discharging the entire refrigerant charge. In this case, the unit must be leak tested to determine the location of the leak.

Leak Testing

In the case of loss of the entire refrigerant charge, the unit must be checked for leaks prior to charging the complete system. This can be done by charging enough refrigerant into the system to build the pressure up to approximately 10 psig (69 kPa) and adding sufficient dry nitrogen to bring the pressure up to a maximum of 125 psig (860 kPa). Leak test with an electronic leak detector. Halide leak detectors do not function with R-134a. Water flow through the vessels must be maintained anytime refrigerant is added or removed from the system.

WARNING

Do not use oxygen or a mixture of R-22 and air to build up pressure as an explosion can occur causing serious personal injury.

If any leaks are found in welded or brazed joints, or it is necessary to replace a gasket, relieve the test pressure in the system before proceeding. Brazing is required for copper joints.

After making any necessary repair, the system must be evacuated as described in the following section.

Evacuation

After it has been determined that there are no refrigerant leaks, the system must be evacuated using a vacuum pump with a capacity that will reduce the vacuum to **at least 1000 microns of mercury**.

A mercury manometer, or an electronic or other type of micron gauge, must be connected at the farthest point from the vacuum pump. For readings below 1000 microns, an electronic or other micron gauge must be used.

The triple evacuation method is recommended and is particularly helpful if the vacuum pump is unable to obtain the desired 1 millimeter of vacuum. The system is first evacuated to approximately 29 inches of mercury. Dry nitrogen is then added to the system to bring the pressure up to zero pounds.

Then the system is once again evacuated to approximately 29 inches of mercury. This is repeated three times. The first pulldown will remove about 90% of the noncondensables, the second about 90% of that remaining from the first pulldown and, after the third, only 1/10-1% noncondensables will remain.

Charging the System

WSC and WDC water chillers are leak tested at the factory and shipped with the correct charge of refrigerant as indicated on the unit nameplate. In the event the refrigerant charge was lost due to shipping damage, the system should be charged as follows after first repairing the leaks and evacuating the system.

1. Connect the refrigerant drum to the gauge port on the liquid line shutoff valve and purge the charging line between the refrigerant cylinder and the valve. Then open the valve to the mid-position.
2. Turn on both the cooling tower water pump and chilled water pump and allow water to circulate through the condenser and the chiller. (It will be necessary to manually close the condenser pump starter.)
3. If the system is under a vacuum, stand the refrigerant drum with the connection up, and open the drum and break the vacuum with refrigerant gas to a saturated pressure above freezing.
4. With a system gas pressure higher than the equivalent of a freezing temperature, invert the charging cylinder and elevate the drum above the condenser. With the drum in this position, valves open, water pumps operating, liquid refrigerant will flow into the condenser. Approximately 75% of the total requirement estimated for the unit can be charged in this manner.
5. After 75% of the required charge has entered the condenser, reconnect the refrigerant drum and charging line to the service valve on the bottom of the evaporator. Again purge the connecting line, stand the drum with the connection up, and place the service valve in the open position.

IMPORTANT: At this point, the charging procedure should be interrupted and prestart checks made before attempting to complete refrigerant charge. The compressor must not be started at this time. (Preliminary check must first be completed.)

NOTE: It is of utmost importance that all local, national, and international regulations concerning the handling and emission of refrigerants are observed.

Oil Analysis

Interpreting Oil Analysis Data

Oil wear metals analysis has long been recognized as a useful tool for indicating the internal condition of rotating machinery and continues to be a preferred method for Daikin centrifugal chillers. Daikin Service or a number of laboratories specializing in oil testing can do the test. To accurately estimate the internal condition it is essential to properly interpret the oil wear test results.

Numerous test results from various testing laboratories have recommended action that has prompted unnecessary concern by customers. Polyolester oils are excellent solvents and can readily dissolve trace elements and contaminants. Most of these elements and contaminants eventually end up in the oil. Also, the polyolester oils used in R-134a chillers are more hygroscopic than mineral oils and can contain much more water in solution. For this reason, it is imperative that extra care be used when handling polyolester oils to minimize their exposure to ambient air. Extra care must also be used when sampling to ensure that sample containers are clean, moisture-free leak proof and non-permeable.

Daikin has done extensive testing in conjunction with refrigerant and lubricating oil manufacturers and has established guidelines to determine action levels and the type of action required. Table 1 indicates these parameters.

In general Daikin does not recommend changing lubricating oils and filters on a periodic basis. The need to change lubricating oil and filters should be based on a careful consideration of oil analysis, vibration analysis and knowledge of the operating history of the equipment. A single oil sample is not sufficient to estimate the condition of the chiller. Oil analysis is only useful if employed to establish wear trends over time. Changing

lubricating oil and filter prior to when its needed will reduce the effectiveness of oil analysis as a tool in determining machinery condition.

The following metallic elements or contaminants and their possible sources will typically be identified in an oil wear analysis.

Aluminum

Typical sources of aluminum are bearings, impellers, seals or casting material. An increase in aluminum content in the lubricating oil may be an indication of bearing, impeller or other wear. A corresponding increase in other wear metals may also accompany an increase in aluminum content.

Copper

The source of copper can be the evaporator or condenser tubes, copper tubing used in the lubrication and motor cooling systems or residual copper from the manufacturing process. The presence of copper may be accompanied by a high TAN (total acid number) and high moisture content. High copper contents may also result from residual mineral oil in machines which have been converted to R-134a. Some mineral oils contained wear inhibitors which react with copper and result in high copper content in lubricating oil.

Iron

Iron in the lubricating oil can originate from compressor castings, oil pump components, shells, tube sheets, tube supports, shaft material and rolling element bearings. High iron content may also result from residual mineral oil in machines which have been converted to R-134a. Some mineral oils contain wear inhibitors which react with iron and can result in a high iron content in the lubricating oil.

Tin

The source of tin may be from bearings.

Zinc

There is no zinc used in the bearings on Daikin chillers. The source, if any may be from additives in some mineral oils.

Lead

The source of lead in Daikin centrifugal chillers is the thread sealant compounds used during chiller assembly. The presence of lead in the lubricating oil in Daikin chillers does not indicate bearing wear.

Silicon

Silicon can originate from residual particles of silicon left from the manufacturing process, filter drier material, dirt or anti-foam additives from residual mineral oil which may be present in machines that have been converted to R-134a.

Moisture

Moisture in the form of dissolved water can be present in lubricating oil to varying degrees. Some polyolester oils may contain up to 50 parts per million (ppm) of water from new unopened containers. Other sources of water may be the refrigerant (new refrigerant may contain up to 10 ppm water), leaking evaporator condenser tubes or oil coolers, or moisture introduced by the addition of either contaminated oil or refrigerant or improperly handled oil.

Liquid R-134a has the ability to retain up to 1400 ppm of water in solution at 100 degrees F. With 225 ppm of water dissolved in liquid R-134a, free water would not be released until the liquid temperature reached -22 degrees F. Liquid R-134a can hold approximately 470 ppm at 15 degrees F (an evaporator temperature which could be encountered in ice applications). Since free water is what causes acid production, moisture levels should not be of a concern until they approach the free water release point.

A better indicator of a condition which should be of concern is the TAN (Total Acid Number). A TAN below 0.09 requires no immediate action. TANs above 0.09 require certain actions. In the absence of a high TAN reading and a regular loss of refrigerant oil (which may indicate a heat transfer surface leak) a high moisture content in an oil wear analysis is probably due to handling or contamination of the oil sample. It should be noted

that air (and moisture) can penetrate plastic containers. Metal or glass containers with gasket in the top will slow moisture entry.

In conclusion, a single element of an oil analysis should not be used as the basis to estimate the overall internal condition of a Daikin chiller. The characteristics of the lubricants and refrigerants, and knowledge of the interaction of wear materials in the chiller must be considered when interpreting a wear metal analysis. Periodic oil analysis performed by a reputable laboratory and used in conjunction with compressor vibration analysis and operating log review can be helpful tools in estimating the internal condition of a Daikin chiller.

Normal Sample Intervals

Daikin International recommends that an oil analysis be performed annually. Professional judgment must be exercised under unusual circumstances, for example, it might be desirable to sample the lubricating oil shortly after a unit has been placed back into operation after it has been opened for service, as recommended from previous sample results or after a failure. The presence of residual materials from a failure should be taken into consideration in subsequent analysis. While the unit is in operation, the sample should be taken from a stream of refrigerant oil, not in a low spot / quiet area.

Table 17, Upper Limit For Wear Metals And Moisture In Polyolester Lubricants In Daikin Centrifugal Chillers

Elements	Upper Limit (ppm)	Action
Aluminum	50	1
Copper	100	1
Iron	100	1
Moisture	150	2 & 3
Silica	50	1
Total Acid Number (TAN)	.19	3

Key To Action

1. Re-sample after 500 hours of unit operation. If content increases less than 10%, change oil and filter and re-sample at normal interval. If content increases 25% or more, inspect compressor.
2. Re-sample after 500 hours of unit operation. If content increases less than 10%, change filter drier and re-sample at normal interval. If content increases 25% or more, monitor for water leak. Since POE lubricants are hygroscopic, many times the high moisture level is due to inadequate handling and packaging. The TAN reading **MUST BE USED** in conjunction with moisture readings
3. For TAN between .10 and .19, re-sample after 1000 hours of unit operation. If TAN increases above .19, change oil, oil filter and filter drier and re-sample at normal interval.

Maintenance Schedule

Maintenance Check List Item	Daily	Weekly	Monthly	Quarterly	Annually	5-Yr	As Req'd
I. Unit							
· Operational Log	O						
· Analyze Operational Log		O					
· Refrigerant Leak Test Chiller		O					
· Test Relief Valves or Replace						X	
II. Compressor							
· Vibration Test Compressor					X		
A. Motor							
· Meg. Windings (Note 1)					X		
· Ampere Balance (within 10% at RLA)				O			
· Terminal Check (Infrared temperature measurement)					X		
· Motor Cooling Filter Drier Pressure Drop					X		
B. Lubrication System							
· Clean Oil Cooler Strainer (water)					X		
· Oil Cooler Solenoid Operation				O			
· Oil Appearance (clear color, quantity)		O					
· Oil Filter Pressure Drop			O				
· Oil Analysis (Note 5)					X		
· Oil change if indicated by oil analysis							X
III. Controls							
A. Operating Controls							
· Calibrate Temperature Transducers					X		
· Calibrate Pressure Transducers					X		
· Check Vane Control Setting and Operation					X		
· Verify Motor Load Limit Control					X		
· Verify Load Balance Operation					X		
· Check Oil Pump Contactor					X		
B. Protective Controls							
· Test Operation of:							
Alarm Relay				X			
Pump Interlocks				X			
Guardistor and Surgeguard Operation				X			
High and Low Pressure Cutouts				X			
Oil Pump Pressure Differential Cutout				X			
Oil Pump Time Delay				X			

Continued on next page.

Maintenance Schedule, Cont.

Maintenance Check List Item	Daily	Weekly	Monthly	Quarterly	Annually	5-Yr	As Req'd
IV. Condenser							
A. Evaluation of Temp Approach (NOTE 2)			O				
B. Test Water Quality				V			
C. Clean Condenser Tubes (NOTE 2)					X		X
D. Eddy current Test - Tube Wall Thickness						V	
E. Seasonal Protection							X
V. Evaporator							
A. Evaluation of Temp Approach (NOTE 2)			O				
B. Test Water Quality					V		
C. Clean Evaporator Tubes (NOTE 3)							X
D. Eddy current Test - Tube Wall thickness						V	X
E. Seasonal Protection							X
VI. Expansion Valves							
A. Operational Evaluation (Superheat Control)				X			
VII. Starter(s)							
A. Examine Contactors (hardware and operation)				X			
B. Verify Overload Setting and Trip				X			
C. Test Electrical Connections (Infrared temp measurement)				X			
VIII. Optional Controls							
A. Hot Gas Bypass (verify operation)				X			

KEY:

O = Performed by in-house personnel.

X = Performed by Daikin authorized service personnel. (NOTE 4)

V = Normally performed by third parties.

NOTES:

- Some compressors use power factor correction capacitors and all have a surge capacitor (excepting units with solid state starters). The surge capacitor can be installed out of sight in the compressor motor terminal box. In all cases, capacitors must be disconnected from the circuit to obtain a useful Megger reading. Failure to do so will produce a low reading. In handling electrical components, only fully qualified technicians must attempt service.
- Approach temperature (the difference between the leaving water temperature and the saturated refrigerant temperature) of either the condenser or evaporator is a good indication of tube fouling, particularly in the condenser, where constant flow usually prevails. Daikin's high efficiency heat exchangers have very low design approach temperatures, in the order of one to one and one half degrees F.
The chiller unit controller can display the water and the saturated refrigerant temperatures. Simple subtraction will give the approach. It is recommended that benchmark readings (including condenser pressure drop to confirm future flow rates) be taken during startup and then periodically afterward. An approach increase of two-degrees or more would indicate that excessive tube fouling could be present. Higher than normal discharge pressure and motor current are also good indicators
- Evaporators in closed fluid circuits with treated water or anti-freeze are not normally subject to fouling, however it is prudent to check the approach periodically. Some evaporators may have a mixture of ¾-inch and 1-inch tubes.
- Performed when contracted for, not part of standard initial warranty service.
- Oil filter change and compressor teardown and inspection should be done based on the results of the annual oil test performed by a company specializing in this type of test. Consult Daikin Service for recommendations.

Long Term Storage

This information applies to new units being stored waiting for startup or to existing units that may be inoperative for a long period.

The chiller must be stored indoors and protected from any damage or corrosion. A Daikin service representative must perform an inspection and leak test of unit on minimum quarterly schedule, to be paid by the owner or contractor. Daikin will not be responsible for any refrigerant loss during the storage time or repairs to unit during period of storage, or while moving the unit from original location to storage facility and back to new installation location.

The following tasks must be performed:

1. As discussed above, the first and foremost task is to leak test the unit when it is in its final resting place. If any leaks exist, repair them immediately. After the unit is stored, perform a periodic leak test.
2. It is possible that the unit could be bumped, hit or otherwise damaged while in storage; so in addition to leak testing, a visual overall inspection should be done.
3. If there is concern about the possibilities of damage and loss of charge during storage, the customer can pay to have the charge removed and stored in recovery cylinders. If this is done, pressurize it to about 20 psi with nitrogen. Monitor and maintain the pressure. Install a pressure gauge that can easily be read or tie in a remotely alarm that can be monitored if pressure reduces. This is desirable if the unit is stored with refrigerant or with a nitrogen holding charge.
4. If the unit has been shipped and not yet installed, keep it pumped down (as shipped from the factory) and close all refrigerant valves.
5. Keep oil sump valves closed to avoid refrigerant migration to the oil sump. Over a long term, the refrigerant will migrate to the oil tank and displace the oil. The oil will spill over in to the evap. through the vent line and when the unit is powered up and the heaters turned on, the refrigerant will boil out and the sump will be empty.
6. Clean and dry the unit and look for any chipped paint. Touch up as required to prevent rust.
7. If the storage area is subject to a high humidity, consider a shrink wrap or water resistant covering of some sort. Desiccants must be placed inside electrical panels and starters (mounted or shipped loose) and be renewed as recommended by manufacturer.
8. The operator touchscreen monitor, which is shipped loose, should be secured in a dry area. They are subject to pilferage.
9. Regardless of the temperature of the storage area, make sure all vessel tubes are drained and blown dry to prevent the minerals in the standing water, plus oxygen present, causing tube pitting. This includes the oil cooler and water piping.
10. Restart by Daikin service technicians will be required and paid to Daikin by the owner or contractor. It is prudent to take photos when the unit is stored to show that the conditions of storage have been met. Also document all inspection reports and abnormal conditions found. If the unit has been in operation, the run-time hours and number of starts must be documented prior to storage, along with the date the unit taken was out of operation. The extended warranty coverage can be suspended during the storage period-not to exceed 30 months. The remaining warranty time will restart once unit is reinstalled and officially re-commissioned by Daikin.

Service Programs

It is important that an air conditioning system receive adequate maintenance if the full equipment life and full system benefits are to be realized.

Maintenance should be an ongoing program from the time the system is initially started. A full inspection should be made after 3 to 4 weeks of normal operation on a new installation, and on a regular basis thereafter.

Daikin offers a variety of maintenance services through the local Daikin service office, its worldwide service organization, and can tailor these services to suit the needs of the building owner. Most popular among these services is the Daikin Comprehensive Maintenance Contract.

For further information concerning the many services available, contact your local Daikin service office.

Operator Schools

Training courses for Centrifugal Maintenance and Operation are held through the year at the Daikin Training Center in Staunton, Virginia. The school duration is three and one-half days and includes instruction on basic refrigeration, MicroTech controllers, enhancing chiller efficiency and reliability, MicroTech troubleshooting, system components, and other related subjects. Further information can be found on

www.DaikinApplied.com or call the company at 540-248-0711 to speak to the Training Department.

Warranty Statement

Limited Warranty

All Daikin equipment is sold pursuant to Daikin International's Standard Terms and Conditions of Sale and Limited Product Warranty. Consult your local Daikin Representative for warranty details. Refer to form 933-430285Y. To find your local representative, go to www.DaikinApplied.com

Daikin Training and Development

Now that you have made an investment in modern, efficient Daikin equipment, its care should be a high priority. For training information on all Daikin HVAC products, please visit us at www.DaikinApplied.com and click on training, or call 540-248-9646 to speak to the Training Department.

Warranty

All Daikin equipment is sold pursuant to Daikin standard terms and conditions of sale, including Limited Product Warranty. Consult your local Daikin Representative for warranty details. To find your local Daikin Representative, go to www.DaikinApplied.com.

This document contains the most current product information as of this printing. For the most up-to-date product information, please go to www.DaikinApplied.com.

