

WSAT-XEE

352 - 802

High efficiency air-cooled water chiller
for outdoor installation

Installation use and maintenance manual



Dear Customer,

We congratulate you on choosing these product.

Clivet is being working for years to offer systems able to assure the maximum comfort for long time with high reliability, efficiency , quality and safety. The target of the company is to offer advanced systems, that assure the best comfort, reduce the energy con-sumption, the installation and maintenance costs for all the life-cycle of the system.

With this manual, we want to give you information that are useful in all the phases: from the reception, to the installation and use until the disposal so that a system so advanced offers the best procedure of installation and use.

Best regards and have a nice reading !

CLIVET Spa

The data contained in this bulletin is not binding and may be changed by the manufacturer without prior notice. All reproduction, even partial, is prohibited.

INDEX



1	General	4
2	Reception	6
3	Positioning	8
4	Water connections	9
5	Electrical connections	14
6	Start-up	22
7	Control	27
8	Maintenance	43
9	Disposal	46
10	Residual risks	47
11	Technical information	48

1 - GENERAL

1.1 MANUAL

The manual provides correct unit installation, use and maintenance.

Pay particular attention to:

-  Warning identifies particularly important operations or information .
-  Prohibited operations that must not be carried out, that compromise the operating of the equipment or may cause damage to persons or things.
 - It is advisable to read it carefully so you will save time during operations.
-  • Follow the written indications so you will not cause damages to things and injuries people. The preliminary information must be read prior to carrying out any of the following operations.

1.2 GENERAL INSTRUCTIONS

Preliminaries

-  The positioning, hydraulic system, refrigerating, electrics and the channelisation of the air must be determined by the system designer in accordance with local regulations in force.

On the unit can operate only qualified personal , as determined by the regulations in force.

Using the unit in case of breakdown or malfunction :

- voids the warranty
- may compromise the safety of the machine
- may increase time and repair costs.

Follow local safety regulations. .

Keep packing material out of children's reach it may be dangerous. .

Recycle and dispose of packing material in conformity with local regulations. .

Risk situations

-  The unit has been designed and created to prevent injures to people.

During designing it is not possible to plane and operate on all risk situation.

Read carefully "Residual risk" section where all situation which may cause damages to things and injuries to people are reported.

Installation, starting, maintenance and repair required specific knowledge; if they are carried out by inexperienced personnel, they may cause damages to things and injuries people.

Intended use

-  Use the unit for cooling water or a water and glycol mix for air-conditioning only, within limits defined in the technical bulletin and on this manual..

Any use other than intended does not involve the manufacturer in any commitment or obligation. .

Installation

-  Verify that the electrical line characteristics are in compliance with data quotes on the unit serial number label.

Maintenance

-  Plan periodic inspection and maintenance in order to avoid or reduce repairing costs.
- Turn the machine off before any operation.

Modification

-  All unit modifications will end the warranty coverage and the manufacturer responsibility. .

Breakdown/Malfuction

Disable the unit immediately in case of breakdown or malfunction. .

Contact a constructor certified assistance service.

Use original spares parts only.

User training

-  The installer has to train the user on :

- start-up / shutdown;
- set points change;
- standby mode;
- maintenance;
- what to do / what not to do in case of breakdown.

1.2.9 Data update

Continual product improvements may imply manual data changes .

Visit manufacturer web site for updated data.

1.3 INDICATIONS FOR THE USER

-  Keep this manual with the wiring diagram in an accessible place for the operator.

Note the unit lable data so you can provide them at the assistance centre in case of intervention (see "Unit identification" section).

Provide a machine notebook that allows any interventions carried out on the machine to be noted and tracked making it easier to suitably note the various interventions and aids the search for any breakdowns.

In case of breakdown or malfunction:

- immediately deactivate the unit .
- contact a constructor certified assistance service.
- use original spares parts only

-  Ask the installer to format on:

- start-up / shutdown;
- set points change;
- standby mode;
- maintenance;
- what to do / what not to do in case of breakdown.

1 - GENERAL

1.4 UNIT IDENTIFICATION

Serial number label

The serial number label is positioned on the unit and allows to identify all the unit features.



It has not to be removed for any reason.

It reports the regulations indications such as:

- machine type, exmple:
 - Series → **WSAT XEE**
 - Size → **352.....802**
- serial number
 - 12 characters → **Axxxxxxxxxx**
- year of manufacture
- wiring diagram number
- electrical data
- manufacturer logo and address .

Serial number

It identifies uniquely each machine.

It identifies specific spare parts for the machine.

Assistance request

Note data from the serial number label and write them in the chart on side, so you will find them easily when needed.

In case of intervention you have to provide data.

Typology
Size
Serial number
Year of manufacture
Wiring diagram

1.5 ACCESSORIES

VERSIONS OPTIONS

- EXC Excellence
- PRM Premium
- D Partial energy recovery
- R Total energy recovery
- B Water low temperature
- SC Acoustic configuration with compressor soundproofing
- EN Extremely low noise acoustic configuration
- FCD FREE-COOLING diretto (disponibile solo con opzioni:EXC)

CONFIGURATIONS

- CREFP Device for consumption reduction of the external section at variable speed (phase-cutting)
- CREFB Device for consumption reduction of the external section ECOBREEZE fans

REFRIGERANT CIRCUIT

- CCCA Copper / aluminium condenser coil with acrylic lining
- CCCA1 Copper / aluminium condenser coil with Energy Guard DCC Aluminum
- MHP High and low pressure gauges
- OHE Limit extension kit in heating up to -10°C (W.B.)

HYDRAULIC CIRCUIT

- 2PM Hydropack with 2 pumps
- 1PUS Standard pump
- 1PU1SB Standard pump with emergency pump
- AX00 X00-litre storage tank
- AX00RPS X00-litre storage tank with primary circuit onboard
- Water connections:
- ABU Flush hydraulic connections
- IFWX Water steel mesh strainer

SYSTEM ADMINISTRATORS

- CMSC10 Serial communication module to LonWorks supervisor
- CMSC8 Serial communication module to BACnet supervisor
- CMSC9 Serial communication module to MODBUS supervisor

ELECTRIC CIRCUIT

- RCMRX Remote control via microprocessor control
- CONTA2 Energy meter
- ECS ECOSHARE function for the automatic management of a group of units
- PM Phase monitor
- MF2 Multi-function phase monitor
- SFSTR Disposal for inrush current reduction
- PFPC Power factor correction capacitors (cosfi > 0.9)
- SPC2 Set point compensation with outside temperature probe
- SCP4 Compensation of set point with signal 0-10 V
- PSX Mains power supply (available only with options: RCMRX)

INSTALLATION

- AMMX Spring antivibration mounts
- PGFC Finned coil protection grill
- PGCCH Anti-hail protection grilles

2 - RICEPTION

2.1 PRELIMINARY INFORMATION



Operate in compliance with safety regulations in force .

For detailed information (dimensions, weight, technical characteristics etc.) please refer to the "Technical information" section.

Use single protection devices : gloves, glasses ecc. .

2.2 DELIVERY CONTROL



Before accepting the delivery you have to check:

- That the unit hasn't been damaged during transport.
- Check that the materials delivered correspond with that indicated on the transport document comparing the data with the identification label 'A' positioned on the packaging.

In case of damage or anomaly:

- Write down on the transport document the damage you found and quote this sentence: "Conditional acceptance — clear evidence of deficiencies/ damages during transport".
- Contact supplier and the carrier by fax and registered mail with advice of receipt.

Any disputes must be made within the 8 days following the delivery. Complaints after this period are invalid..

2.3 HANDLING

1. Verify unit weight and handling equipment lifting capacity .
2. Identify critical points during handling (disconnected routes, flights, steps, doors)
3. Use protection to avoid the unit damaging .
4. Lifting brackets
5. Lifting beam with spacers
6. Lifting with spacer bar
7. Align the barycentre to the lifting point
8. Use all the lifting brackets (see "Technical informations - dimensions)
9. Gradually bring the lifting belts under tension, making sure they are positioned correctly. .
10. Before handling verify that the unit keeps its balance.

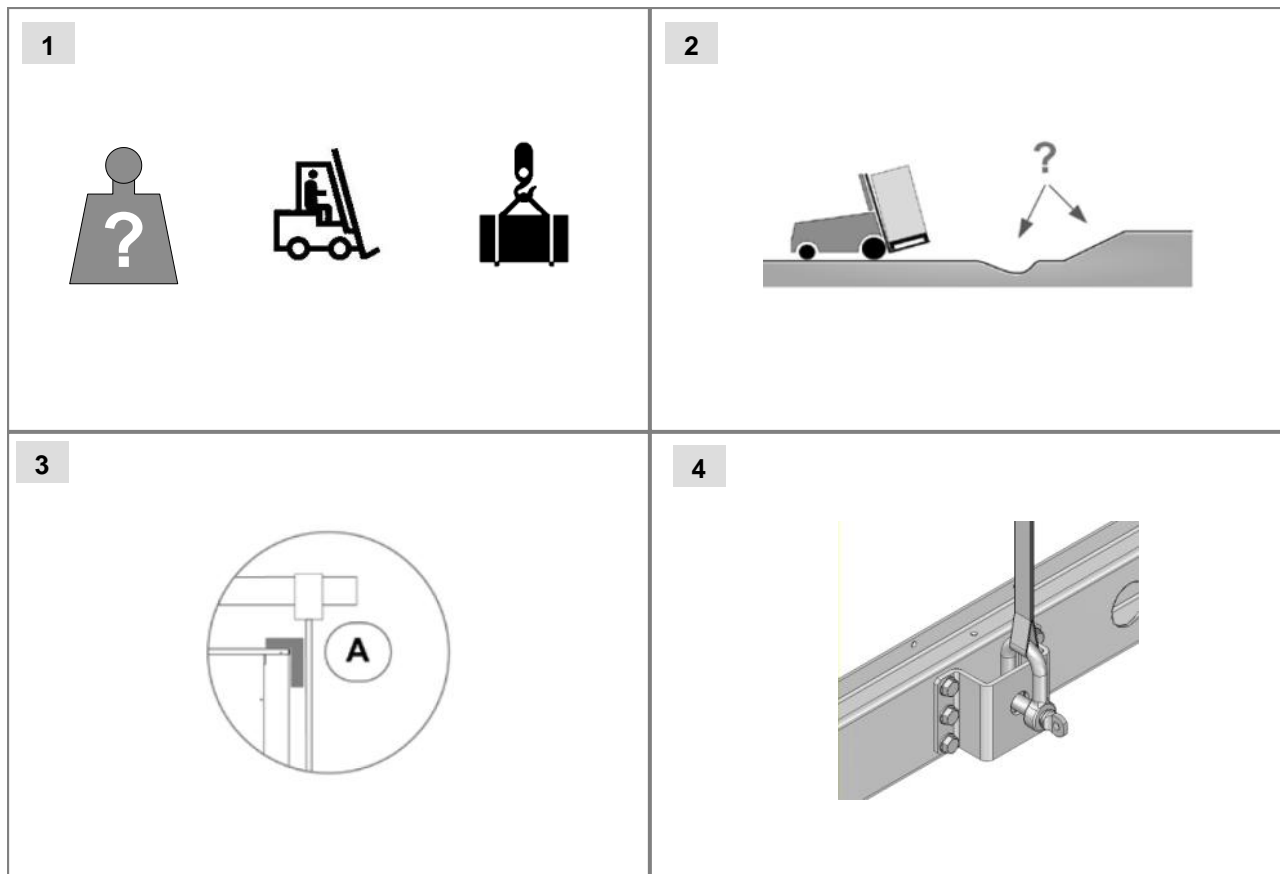

2 - RICEPTION

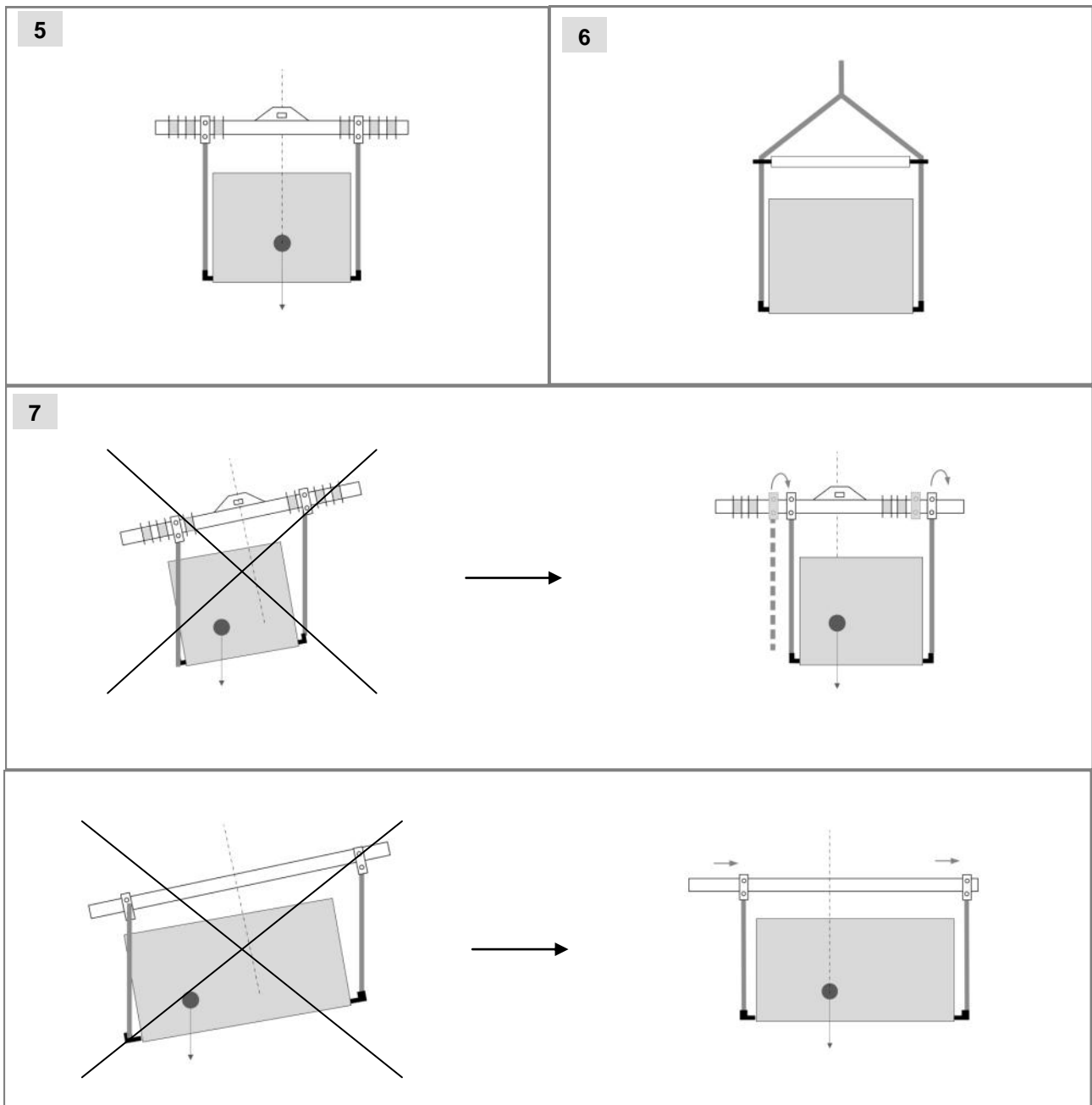

2.4 STORING

Observe external packing instructions .

2.5 PACKING REMOVING

Be careful not to damage the unit.

Recycle and dispose of packing material in conformity with local regulations.

3 - POSITIONING

3.1 PRELIMINARY INFORMATION

Operate in compliance with safety regulations in force.

For detailed information (dimensions, weight, technical characteristics etc.) please refer to the TECHNICAL INFORMATION section.

 Use single protection devices : gloves, glasses ecc.

During positioning consider these elements :

- technical spaces required for the machine and system
- place where the machine will be installed
- electrical connections
- water connections
- air / aeraulic ducts

 Do not consider these elements could decrease performances and operational life of the unit.

3.2 FUNCTIONAL SPACES

Functional spaces are designed to:

- guarantee good unit operation
- Carry out maintenance operations
- protect authorized operators and exposed people

 Respect all functional spaces indicated in the TECHNICAL INFORMATION section.

Double all functional spaces if two or more unit are aligned.

3.3 POSITIONING

 Units are designed to be installed:

- EXTERNAL
- in fixed positions.

Limit vibration transmission:

- use antivibration devices on unit bearing/supporting points;
- install flexible joints on the hydraulic.

Installation standards:

- Safe accessible position;
- avoid flood-prone places;
- verify unit weight and bearing point capacity;
- verify that all bearing points are aligned and leveled;
- install the unit raised from the ground;
- consider the maximum possible snow level

A correct circulation of the air is indispensable to guarantee the good working order of the machine.

 Avoid therefore:

- obstacles to the airflow;
- exchange difficulties;



- leaves or other foreign bodies that can obstruct the exchange batteries;
- winds that hinder or favour the airflow;
- heat or pollution sources close to the unit (chimneys, extractors etc);
- stratification (cold air that stagnates at the bottom);
- recirculation (expelled air that is sucked in again);
- positioning below the level of the threshold, close to very high walls, attics or in angles that could give rise to stratification or recirculation phenomenons.

Ignoring the previous indications could:

- energy efficiency decrease;
- blocks due to HIGH PRESSURE (in summer) or LOW PRESSURE (in winter).

3.4 FRESH AIR PROBE

The external probe allows to automatically change the unit setpoint according to the external enthalpy (temperature + humidity).

In this way is not possible to optimize the unit energy efficiency .

In the winter operating also the defrosting times are optimized.

POSITIONING

The sensor must not be influenced by factors that can cause a false reading (for example direct sun rays, air expelled by the fan or other sources, contact with the unit structure or other heat sources, accumulation of snow/ice).

Example for the positioning of the external probe:

- A attic
- B Underneath a terrace
- C If attached to external wall provide a small roof framework

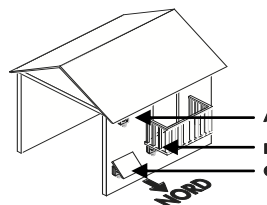

4 - WATER CONNECTIONS

4.1 PRELIMINARY INFORMATION

Selection and installation of system components must be carry out by installer.

Following you will find some indications to integrate with what is provided by the local regulations in force and by the good technical laws.

4.2 COMPONENTS

CUT-OFF VALVES :

- installed at inlet and outlet (both on the water technique circuit as well as that of the hot domestic water) allow maintenance operations without having to empty the system .

THERMOMETERS AND MANOMETERS :

- installed at entry and exit of the main elements facilitate inspection and maintenance.

AN AIR BLEED VALVE :

- installed in all of the highest points of the system allowing the venting of the circuits air..



DRAINAGE TAPS :

- installed in the lowest points of the system to allow bleeding.

EXPANSION TANK :

- It keeps a correct system pressure when the water temperature changes. It must be dimensioned as a function of water content.

WATER FILTER :

-  if not present on-board the machine, must be installed immediately in the water input of the unit, in a position that is easily accessible for cleaning.
-  The filter never should be removed, this operation invalidates the guaranty

SUPPORTI :

- The hydraulic pipes weight mustn't burden on the unit connections ..

FLOW SWITCH

- The flow switch must be present as a component of the system

4.3 OPERATION SEQUENCE

Before connecting the unit, carefully wash the system by filling it and emptying it several times with clean water.

Ignoring this operation will lead to several filter cleaning interventions and at worst cases can cause damages to the exchangers and the other parts.

Execute leakage test before isolate the pipes.

To avoid heat dispersions and formation of condensate isolate all the pipes. Leave various point of service free (wells, vent-holes etc).

4.4 WATER QUALITY

The water quality can be checked by qualified personnel.

Water with inadequate characteristics can cause:

- pressure drop increase
- energy efficiency decrease
- corrosive symptom increase

Water quality: acceptable values

PH	7,5 + 9,0	
SO ₄ ⁻	< 100	ppm
HCO ₃ ⁻ / SO ₄ ⁻	> 1	
Total Hardness	4,5 + 8,5	dH
Cl ⁻	< 50	ppm
PO ₄ ³⁻	< 2,0	ppm
NH ₃	< 0,5	ppm
Free Chlorine	< 0,5	ppm
Fe ₃ ⁺	< 0,5	ppm
Mn ⁺⁺	< 0,05	ppm
CO ₂	< 50	ppm
H ₂ S	< 50	ppb
Temperature	< 65	°C
Oxygen content	< 0,1	ppm

4.5 RISK OF FREEZE

 If the unit or the relative water connections can be subject to temperatures close to 0°C adopt measures for prevent risk of freeze.

For example:

- Mix water with ethylene glycol
- Safeguard the pipes with heating cables placed under the insulation
- Empty the system in cases of long non-use and check that:
 - there are no closed taps present that could trap water even after emptying
 - there are no low points in which water can stagnate even after emptying; carry out any blowing required .

4.6 ANTI-FREEZE SOLUTION

Consider that the use of anti-freeze solution determines an increase in a pressure drop.

 Make sure that the glycol type utilized is inhibited (not corrosive) and compatible with the hydraulic circuit components (pump etc).

 Keine Gemische aus unterschiedlichen Glykolarten benutzen (z.B. Ethyl mit Propylenglykol).

4 - WATER CONNECTIONS

4.7 RECOMMENDED CONNECTION

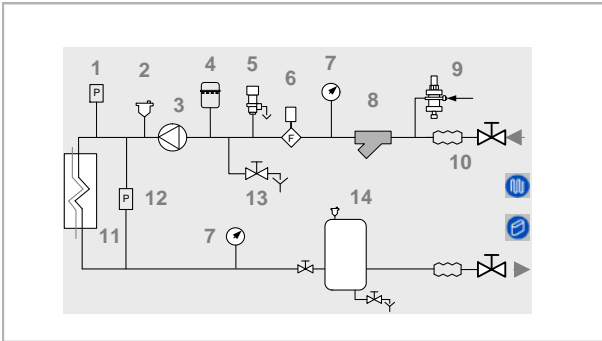

1. Charged system pressure switch
2. vent
3. circulating pump / pump
4. expansion tank
5. safety valve
6. flow switch
7. pressure switch / thermometer
8. filter
9. filling valve
10. antivibration joints
11. user side exchanger
12. Differential pressure switch
13. Discharge cock
14. inertial storage tank

4.8 VICTAULIC CONNECTIONS

- Take away the supplied connection union by acting on the connection joint.
- Weld the union to the installation pipe.
- Perform the connection between the installation pipe and the evaporator, using the joint.

Do not weld the system pipe with the connection joint attached.

The rubber gasket might be irreparably damaged.



4.9 RECOVERY EXCHANGER

OPTIONAL

The unit can be equipped with exchangers to recover the condensation heat.

The customer is responsible for the management of the circulation pump, valves, thermostats, etc

The recovery input water must not be below 25°C, in the event that, wrongful operations and breakages of the unit can occur .

Water connections must be performed carefully as for the evaporator (filter, circuit washing, etc) .

Perform all necessary interventions to avoid the RISK OF FREEZING (tubes insulation, emptying of circuit, addition of glycol, anti-freeze resistances) .

Water temperature can reach high temperatures (up to 100° C), therefore:

- avoid the RISK OF BURNS by adopting the necessary precautions (insulation of tubes, temperature detecting station on water if the sanitary use is foreseen, etc).
- Install safety valves and specifically dimensioned expansion tanks in the hydraulic circuit.

4.10 OPTION CONNECTIONS FLUSH THE UNIT

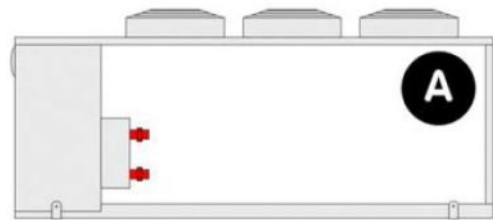

A - standard unit
B - Unit with ABU option

4 - WATER CONNECTIONS

4.11 HYDROPACK

OPTIONAL

PUMPING STATION

Available in the versions:

- Single pump
- Double pump
 - in this configuration one pump acts as backup of the other. The microprocessor automatically balances the operating hours of both the pumps and, in case of failure, the unit signals the lockout of the pump out of use.
- Hydropack with 2 pumps
 - the pump operating acts in parallel. Thanks to this modular structure, the water flow-rate can be automatically reduced if the temperature increases over the operating limit. This device is very useful during starts-up, weekend pauses, and after a long period of inactivity. When the water temperature of the hydronic circuit is very high, possible blocks for overcharging are avoided, as well as the consequent interventions of specialized personnel for the assisted start-up. In case of failure of one pump, the unit continues to operate guaranteeing the 60% of the nominal flow-rate.

INERTIAL STORAGE TANK

It is available in the standard version and in the primary/secondary version to respond to different types of systems.

Version with one/two pumps with storage tank

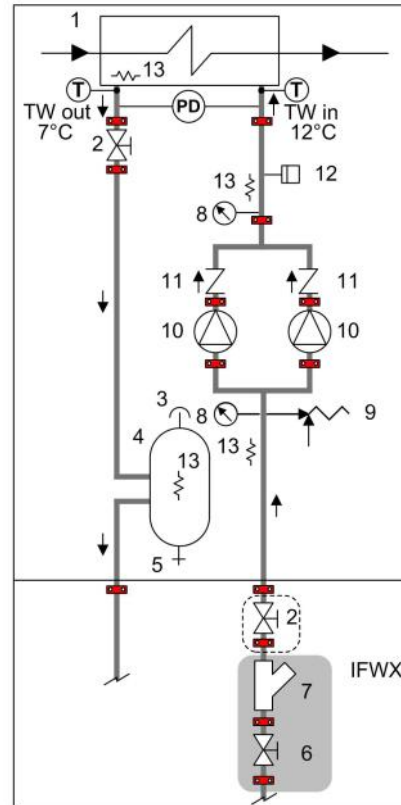

Version with one/two pumps

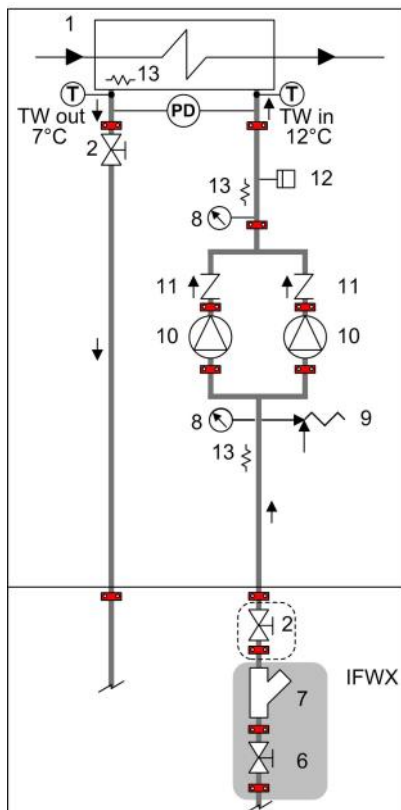

Version with one/two pumps with 1°/2° circuit storage tank

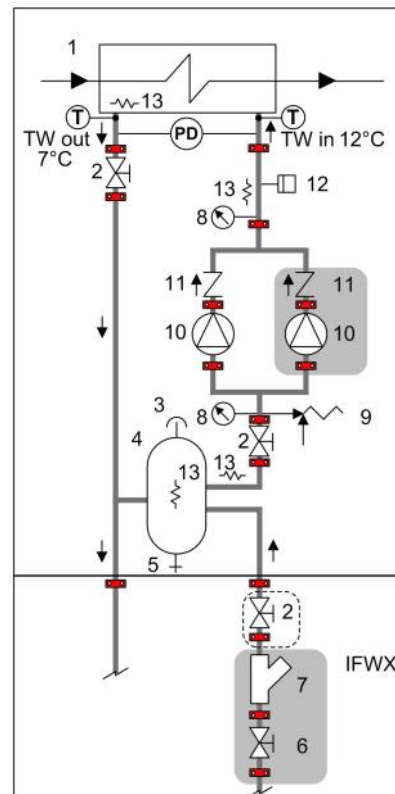

4 - WATER CONNECTIONS

4.11 FREE-COOLING - OPTION

When the temperature of the fresh air is lower than the temperature of the return water of the system, the free-cooling version lets you recover cold from the external environment, reducing the work of the compressors all the way down to nothing.



USE OF ANTI-FREEZE SOLUTIONS

The heat carrier used in the systems that include a Free-Cooling device require a glycol solution (usually an ethylene type). This substance is required because the Free-Cooling units are intended to be installed where the temperature can drop to very low levels during certain times of the year. The percentage of glycol in the solution depends on the low temperatures that can be expected in the place of installation. Therefore, this parameter is at the discretion of the system designer.

Summer

- cooling of the solution is ensured by the refrigerating cycle with operation of the compressors (C) as in a traditional chiller ;
- the Free-Cooling (Bh) coils are not involved.

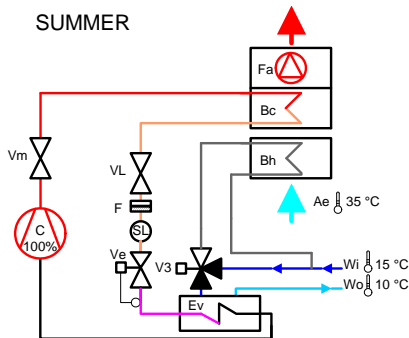

Key

Ae	fresh air	V3	3-way valve
Bc	condensino coil	Ve	electronic expansion valve
Bh	water coil	VL	cock on the liquid line
C	scroll compressor	Vm	cock on the supply line
Ev	plate evaporator	Wi	water inlet
F	dryer filter	Wo	water outlet
Fa	fan		
SL	liquid light		

Intermediate season

The energy savings variable between 0 and 100%, based on the temperature difference between fresh air and the system request.

If the unit detects that the fresh air temperature (Ae) is suitable:

1. it inverts the position of the 3-way valve (V3), forcing the solution to travel through the Free-Cooling coils (Bh) before reaching the evaporator (Ev);
2. it sets the fans (Fa) at maximum speed to obtain maximum cooling of the solution from the fresh air;
3. the solution thus undergoes an initial cooling which is free and natural;

4. the remaining cooling is provided by the refrigeration cycle, with compressors in stepped operation (power absorbed proportional to the degree of stepping);

If the temperature of fresh air increases, the microprocessor will automatically revert operation to summer mode, ensuring the same conditions requested by the user.

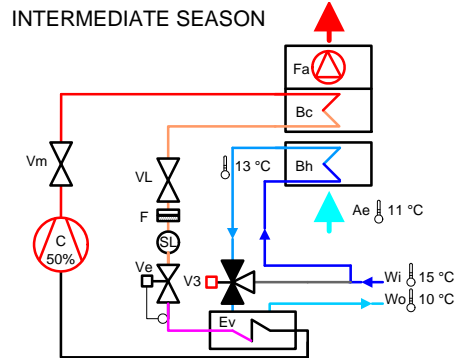

Winter

The three way valve (V3) is in the same position as in the previous case;

- the temperature of the fresh brings the solution at the outlet of the Free-Cooling coils (Bh) to the temperature required for use;
- the microprocessor control completely deactivates all compressors (C), providing all cooling power at no cost, as opposed to standard units;
- if the difference between the temperature of the fresh air (Ae) and that required for use is such that the temperature of the solution at the outlet of the Free-Cooling coils (Bh) drops below the set point required for use (which does not compromise unit safety, because of the glycol in the solution), the microprocessor modulates fan speed (Fa), turning them off if necessary. When the fans are off, if the temperature (Wo) continues to drop, the 3-way valve (V3) positions itself as in summer operation, changing to digital and allowing the set point to be maintained.

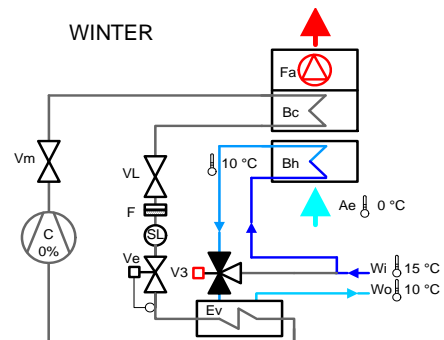

4 - WATER CONNECTIONS

4.12 ENERGY RECOVERY - OPTION

Partial energy recovery

The use of a desuperheater makes it possible to recover, free of charge, the heat that would otherwise be dispersed in the environment. The partial heat recovery is composed of shell and tube heat exchangers suitable for recovery of 25% of the heat power dispersed by the unit (cooling and electrical power of the compressors). If the temperature of the water to be heated is relatively low, it is advisable to insert in the plumbing circuit an adjustment valve to keep the recovery inlet temperature greater than 35°C to prevent condensation.

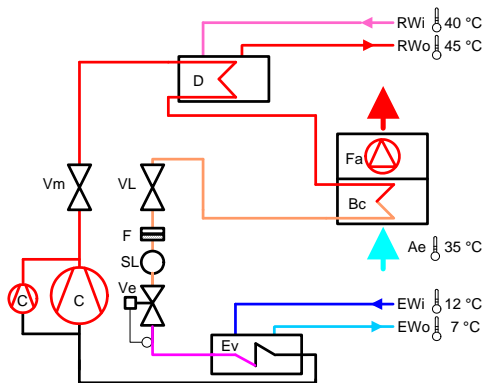

Key			
Ae	fresh air	Ve	electronic expansion valve
Bc	condensing coil	VL	cock on the liquid line
C	compressor	Vm	cock on the supply line
D	heat partial recovery	Vr	valve for total recovery enabling
Ev	evaporator		
EWi	cooled water inlet		
EWO	cooled water outlet		
F	dryer filter		
Fa	fan		
RWi	partial recovery water inlet		
RWO	partial recovery water outlet		
SL	spia del liquido		
Vc	valve for condensing coil		

Recupero energetico totale

The use of total heat recovery may be the optimal solution in all cases that require the production of hot water for medium and large potentials. The production of hot water is always of lesser priority than the production of chilled water. The total heat recovery is composed of shell and tube heat exchangers suitable for recovery of 100% of the heat power dispersed by the unit (cooling and electrical power of the compressors). The unit with total recovery is capable of managing the recovery temperature with thermal adjustment integrated in the micro-processor with two steps. The adjustment of power is managed based on chilled water and may have the following instances:

- 1) Cold request 100%, hot request 0% = circuit active only cold,
- 2) Cold request 100%, hot request 100% = circuit active in cold + recovery,

- 3) Cold request 50%, hot request 100% = circuit active in cold+recovery (in this case the unit can provide only 50% of the requested heat).

With the recovery active the condensing coil (Bc) is deactivated and condensation takes place in the total recovery (R).

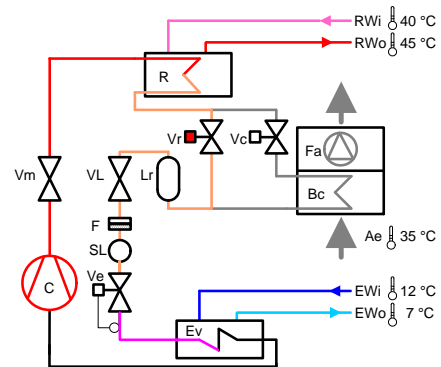

With the recovery setpoint met, the condensing coil (Bc) is reactivated, to perform condensation, via the solenoid valves (Vr=off and Vc=on). In this case the recovery (R) acts as a simple desuperheater.

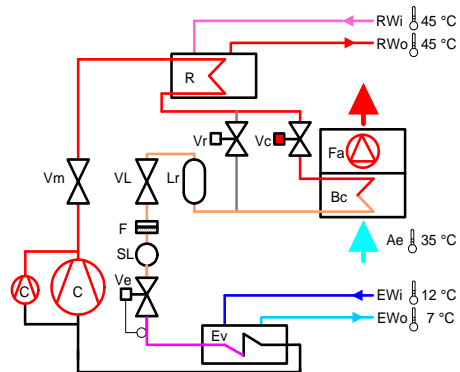

In the plumbing circuit, considering the powers involved, it is advisable to insert a storage tank with suitable capacity to prevent constant commutations of the unit.

5 - ELECTRICAL CONNECTIONS

5.1 PRELIMINARY INFORMATION

The characteristics of the electrical lines must be determined by specialized personnel able to design electrical installations; moreover, the lines must be in conformity with regulations in force.

The protection devices of the unit power line must be able to stop the presumed short circuit current, whose value must be determined in function of system features.

The power cables and the protection cable section must be defined in accordance with the characteristics of the protections adopted. All electrical operations should be performed by trained personnel having the necessary requirements by the regulations in force and being informed about the risks relevant to these activities.

Operate in compliance with safety regulations in force .

5.2 ELECTRICAL DATA



The serial number label reports the unit specific electrical data, included any electrical accessories .

The electrical data indicated in the technical bulletin and in the manual refer to the standard unit, accessories excluded.

Refer to the electrical data report on the serial number label.

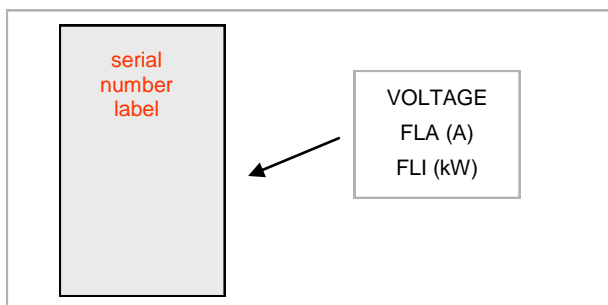

F.L.A. full load ampere
Full load current at max admissible conditions

F.L.I. Full load input
Full load power input
(at max. admissible condition)

5.3 CONNECTIONS

1. refer to the unit electrical diagram (the number of the diagram is shown on the serial number label)
2. verify that the network has characteristics conforming to the data shown on the serial number label
3. Before starting work, verify that the sectioning device at the start of the unit power line is open, blocked and equipped with cartel warning
4. Primarily you have to realize the earthing connection
5. Shelter the cables using adequate measure fairleads

6. Before power the unit, make sure that all the protections that were removed during the electrical connection work have been restored.

5.4 SIGNALS / DATA LINES

Do not overpass the maximum power allowed, which varies, according to the type of signal.

Lay the cables far from power cables or cables having a different tension and that are able to emit electromagnetic disturbances.

Do not lay the cable near devices which can generate electromagnetic interferences.

Do not lay the cables parallel to other cables; cable crossings are possible, only if laid at 90°.

Connect the screen to the ground, only if there aren't disturbances

Guarantee the continuity of the screen during the entire extension of the cable.

Respect impedance, capacity and attenuation indications.

5.5 ELECTRIC LINES INLET

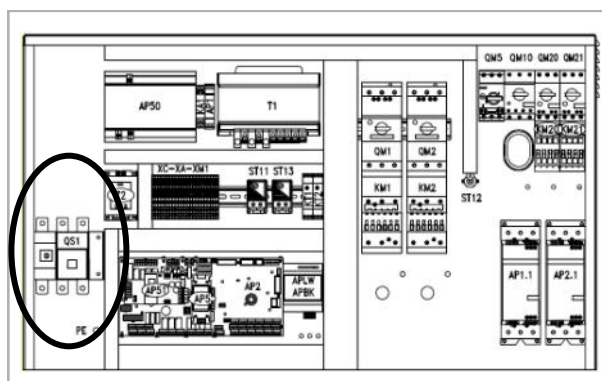
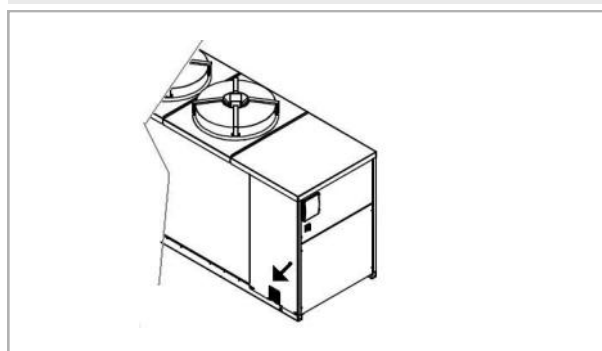

QS1 Main isolator switch

5 - ELECTRICAL CONNECTIONS

5.6 ELECTRICAL PANEL

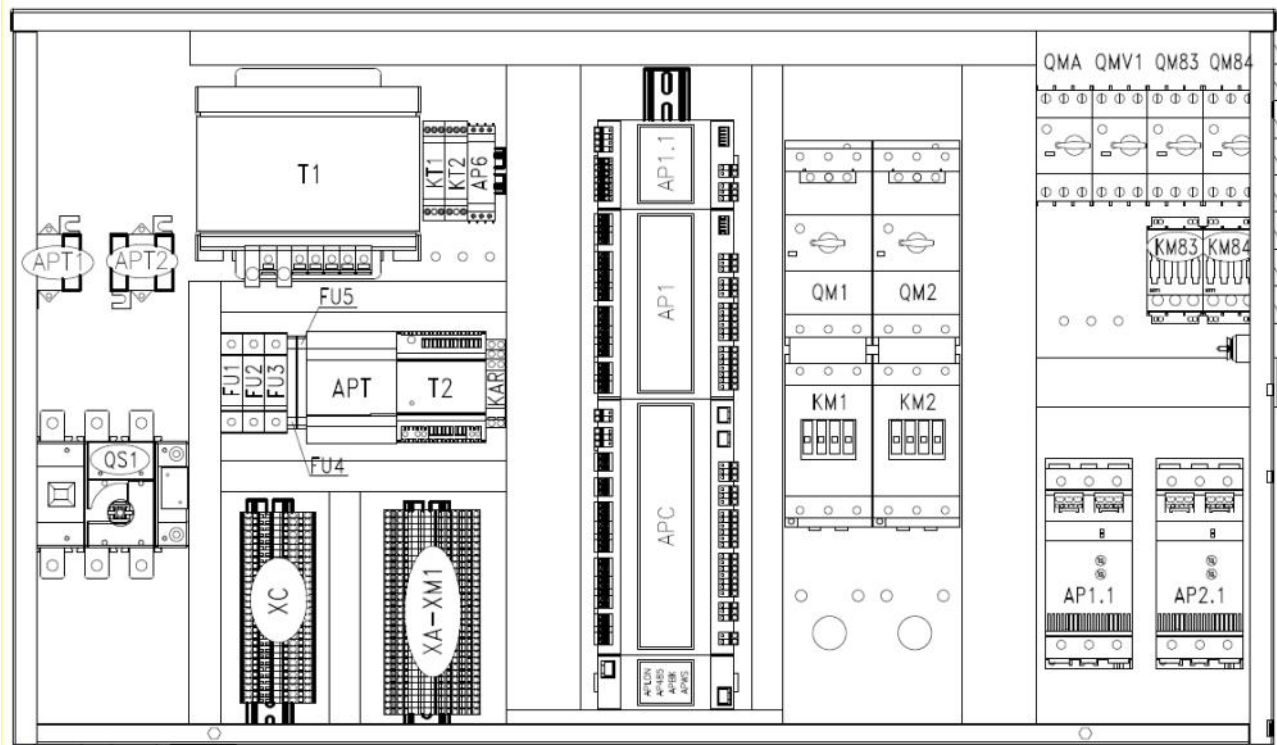

APC	main control module
AP1	compressor control module
AP1.1	electronic thermostatic management board
AP6	phase monitor module
APT	power player
XC	Customer connections
QS1	main isolator

QM1-2	compressor thermal magnetic circuit breaker
KM1-2	compressor contactor
QMA	auxiliary circuit thermal magnetic circuit breaker
QMV	fan motor overload cutout
QM83-4	pump motor overload cutout
KM83-4	pump contactor

5 - ELECTRICAL CONNECTIONS

5.7 STANDARD KEYBOARD

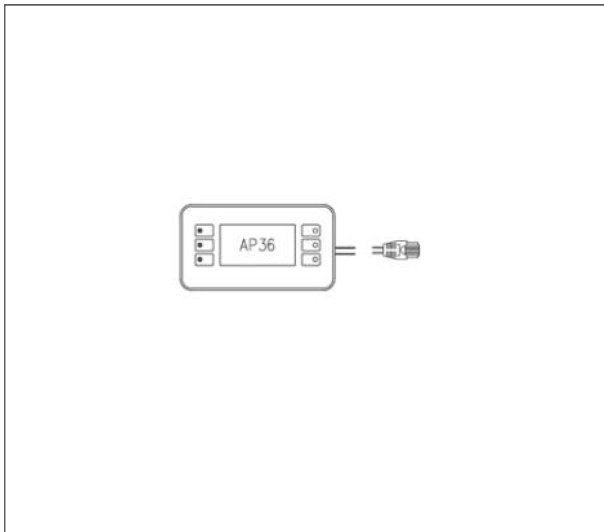

RJ45 : standard connection

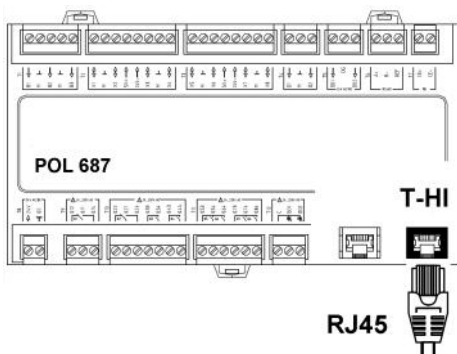

5.8 P.C. - not supplied

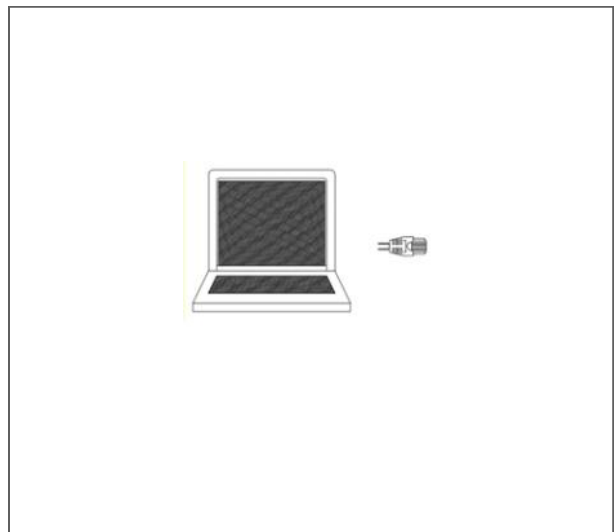

Spostare RJ45 da T-HI a T-IP

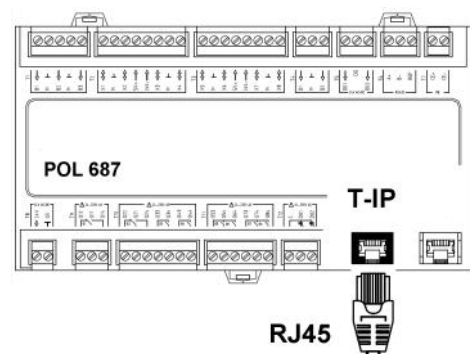

5 - ELECTRICAL CONNECTIONS

5.9 REMOTE KEYPAD

Distance up to 350 mt

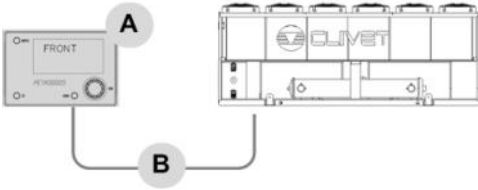

Distance up to 700 mt

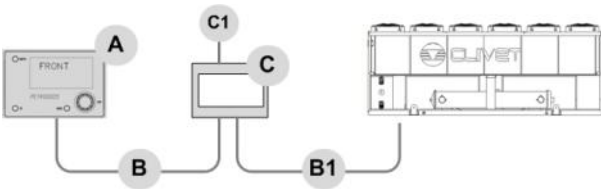

- A remote keypad
- B = B1 KNX bus, max 350 mt
twisted pair with shield, \varnothing 0,8 mm
EIB/KNX cable marking recommended
- C power supply unit N125/11 5WG1 125-1AB11
- C1 AC 120...230 V, 50...60 Hz

Connections

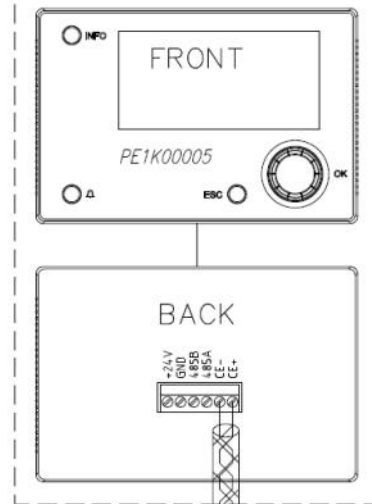

Twisted pair and shielded cable: diameter 0,8 mm
Max 350 m (EIB/KNX marking recommended)

collegamento a tastiera remota
remote keypad connections
raccordement à un clavier déporté
Fern tastatur-Anschluss
conexión con teclado remoto

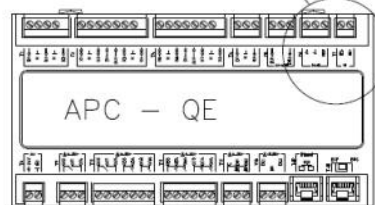
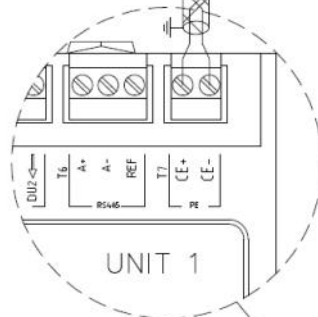

5 - ELECTRICAL CONNECTIONS

5.11 Ecoshare

- Max 7 units
- Maximum length of the bus line: 1000 m.
- maximum distance between 2 units: 700 m.
- Type of cable: shielded twisted pair cable \varnothing 0.8 mm
use an EIB/KNX cable
- Possible connections:
Tree, star, in/out bus, mixed
- It is not possible to use a ring connection
- No end-of-line resistor or terminator required
- There must be suitable arresters to protect the serial lines from the effects of atmospheric discharges
- The data line must be kept separate from the power conductors or powered at different voltage values and away from possible sources of electrical interference

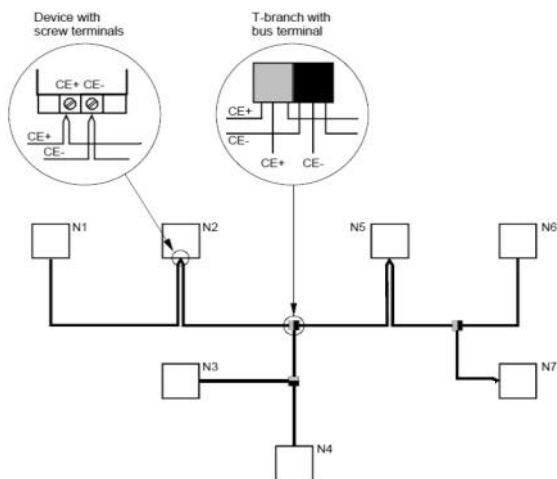
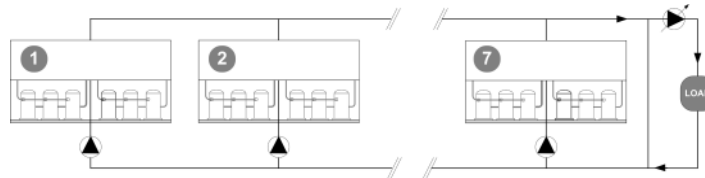
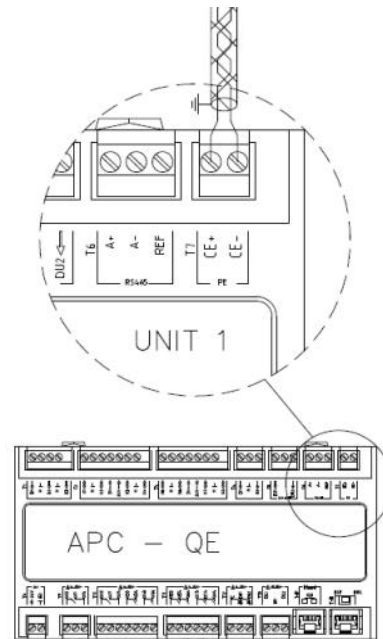

Tree topology (with stub lines)

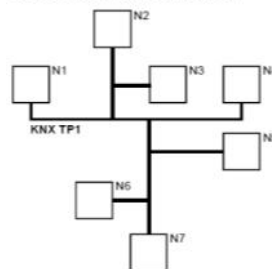

Line topology (with loops)

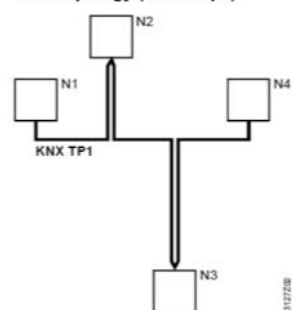

117726

5 - ELECTRICAL CONNECTIONS

5.12 MODBUS - RS485

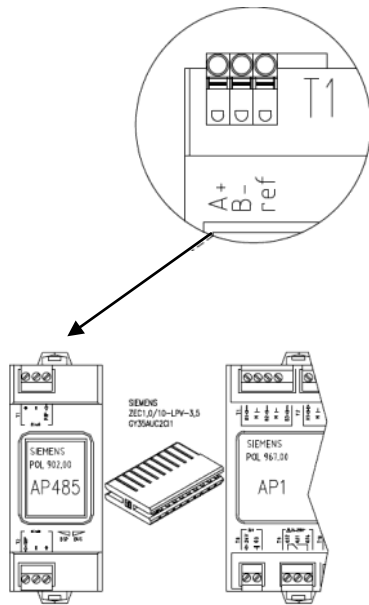

LED BSP

green

yellow

red

communication with AP1 module

communication ok

software ok but communication with AP1 down

flashing : software error

fixed : hardware error

LED BUS

green

yellow

red

communication with MODBUS

communication ok

startup / channel not communicating

communication down

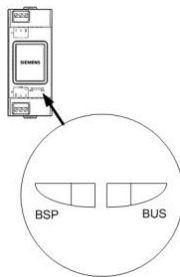

MODBUS Cable requirements

Conductors twisted and shielded

Section of conductor 0.22mm²...0.35mm²

Nominal capacity between conductors < 50 pF/m

nominal impedance 120 Ω

Recommended cable BELDEN 3106A



- Every RS485 serial line must be set up using the 'In/Out' bus system. Other types of networks are not allowed, such as Star or Ring networks

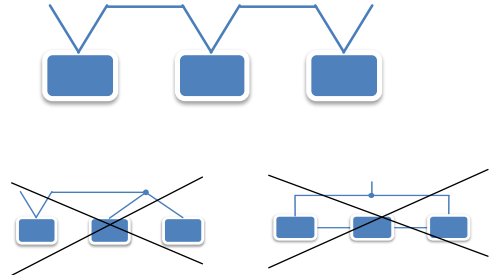

- The difference in potential between the earth of the two RS485 devices that the cable shielding needs to be connected to must be lower than 7 V
- Suitable arresters must be set up to protect the serial lines from the effects of the atmospheric discharges
- A 120 ohm resistance must be located on the end of the serial line. Alternatively, when the last serial board is equipped with an internal terminator, it must be enabled using the specific jumper, dip switch or link
- The cable must have insulation features and non-flame propagation in accordance with applicable regulations
- The RS485 serial line must be kept separate from the power conductors or powered by different voltages
- The RS485 serial line must be kept as far away as possible from sources of electromagnetic interference

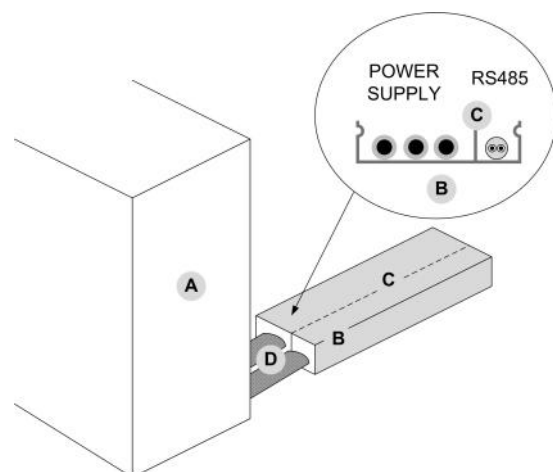

A unit

B metal conduit

C metal septums

D metal-lined sheath (sleeve)

5 - ELECTRICAL CONNECTIONS

5.13 BACNET

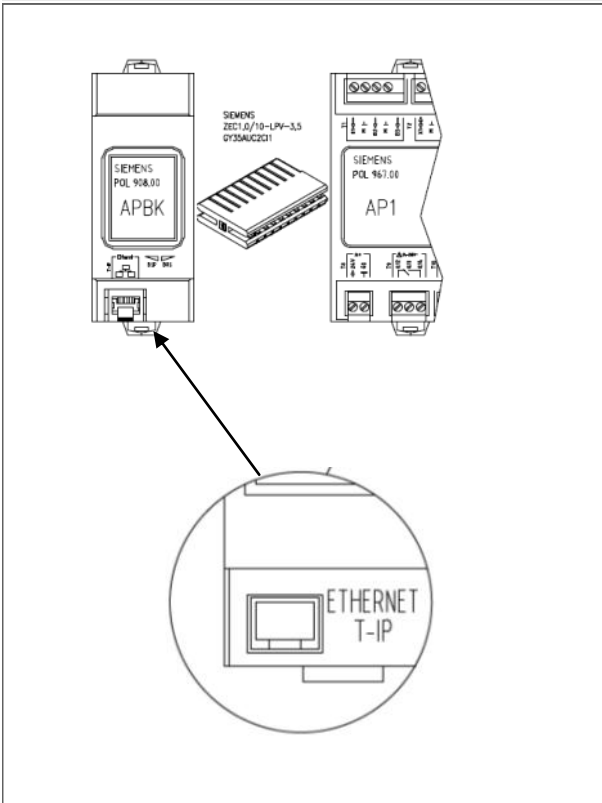

LED BSP	communication with AP1 module
green	communication ok
yellow	software ok but communication with AP1 down
red	flashing : software error
	fixed : hardware error
LED BUS	communication with BACNET
green	ready for communication
yellow	startup
red	BACnet server down
	restart after 3 sec.

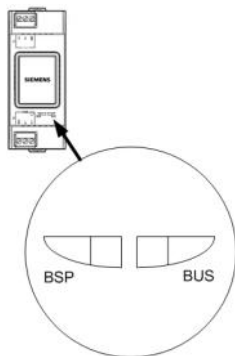

5.14 LONWORK

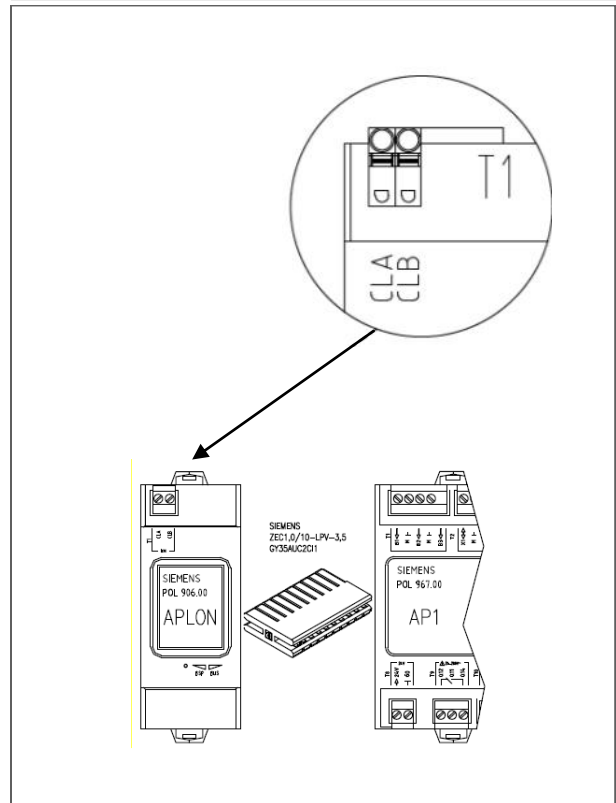

LED BSP	communication with AP1 module
green	communication ok
yellow	software ok but communication with AP1 down
red	flashing : software error
	fixed : hardware error
LED BUS	communication with LONWORK
green	communication ok
yellow	startup
	flashing: communicating not possible
red	communication down

LONWORK CABLE TYPES

Echelon allows three cable types for channel type TP/FT-10, including the

Category 5 network cable used commonly in building automation and control (TIA 568A Cat-5).

CAT-5 SPECIFICATIONS

Unshielded cable, twisted pair with at least 18 beats per meter:

Cross-sectional area Min. \varnothing 0.5mm, AWG24, 0.22mm²

Impedance 100 Ω +/- 15 % @ f > 1 MHz

Operating capacity between two wires of a pair < 46 nF/km

Capacity pair to ground, asymmetric. < 3.3 nF/km

DC loop resistance < 168 Ω

6 - START-UP

PRELIMINARY CHECKS



Checks before the unit starting-up.

✓ Preliminary checks - unit OFF power supply	
1	<input type="checkbox"/> safe access
2	<input type="checkbox"/> functional clearances
3	<input type="checkbox"/> air flow: free return and supply (no bypass, no stratification)
4	<input type="checkbox"/> structure integrity
5	<input type="checkbox"/> the fans turn freely
6	<input type="checkbox"/> unit on antivibrations
7	<input type="checkbox"/> unit input water filter + shut-off valves for cleaning
8	<input type="checkbox"/> antivibrating joints on water connections
9	<input type="checkbox"/> expansion tank (indicative volume = 5% of system content)
10	<input type="checkbox"/> cleaned system
11	<input type="checkbox"/> loaded system + possible glycoled + corrosion inhibitor
12	<input type="checkbox"/> system under pressure
13	<input type="checkbox"/> vented system
14	<input type="checkbox"/> Refrigerant circuit visual check
15	<input type="checkbox"/> earthing connection
16	<input type="checkbox"/> power supply features
17	<input type="checkbox"/> electrical connections by customer

START-UP SEQUENCE



Operations to perform for the unit start-up.

✓ Start-up sequence - unit ON power supply	
1	<input type="checkbox"/> Compressor crankcase resistances operating at least since 8 hours
2	<input type="checkbox"/> No-load voltage measure
3	<input type="checkbox"/> Phase sequence check
4	<input type="checkbox"/> Pump manual start-up and flow check
5	<input type="checkbox"/> Unit ON
6	<input type="checkbox"/> Measure of full load voltages and absorptions
7	<input type="checkbox"/> Check of liquid light (no bubbles)
8	<input type="checkbox"/> Check of all fan operating
9	<input type="checkbox"/> Return and suppli water temperature measure
10	<input type="checkbox"/> Super-heating and sub-cooling measure
11	<input type="checkbox"/> Check that no anomalous vibrations are present
12	<input type="checkbox"/> Date- hour setting
13	<input type="checkbox"/> option settings
14	<input type="checkbox"/> Set-point personalization
15	<input type="checkbox"/> Scheduling personalization
16	<input type="checkbox"/> Complete and available unit documentation

6 - START-UP

6.1 PRELIMINARY INFORMATION

The indicated operations should be done by qualified technician with specific training on the product.

Upon request, the service centres performing the start-up; the electrical, water connections and the other system works are by the installer.

Agree upon in advance the start-up data with the service centre.

6.2 PRELIMINARY CHECKS

Before checking, please verify the following :

- the unit should be installed properly and in conformity with this manual.
- the electrical power supply line should be sectioned at the beginning.
- The line sectionalizing device is open, locked and equipped with the suitable warning
- make sure no tension is present

6.3 REFRIGERANT CIRCUIT

1. Check carefully the refrigerating circuit: the presence of oil stains can mean leakage caused by transportation, movements or other).
2. Verify that the refrigerating circuit is in pressure: Using the unit manometers , if present, or service manometers.
3. Make sure that all the service outlets are closed with proper caps; if caps are not present a leak of refrigerant can be possible.

6.4 HYDRAULIC CIRCUIT

1. Before realizing the unit connection make sure that the hydraulic system has been cleaned up and the clearing water has been drained
2. Check that the water circuit has been filled and pressurized
3. Check that the shut-off valves in the circuit are in the "OPEN" position.
4. Check that there isn't air in the circuit, if required, evacuate it using the air bleed valve placed in the system high points.
5. When using antifreeze solutions, make sure the glycol percentage is suitable for the type of use envisaged.

Weight of glycol (%)	10	20	30	40
Freezing temperature (°C)	-4	-9	-15	-23
Safety temperature (°C)	-2	-7	-13	-21

6.5 ELECTRICAL CIRCUIT

Verify that the unit is connected to the ground plant

Check the conductors tightening: the vibrations caused by handling and transport might cause loosening

Feed the unit by closing the sectioning device, but leave it on OFF.

Check the tension and line frequency values which must be within the limits :

400/3/50 +/- 10%

Control the unbalancing of the phases:

it must be lower than 2%

Example:

1)
$$\frac{388 + 379 + 377}{3} = 381 (y)$$

2)
$$\text{MAX} - y = 388 - 381 = 7$$

3)
$$S = \frac{7}{y} \times 100 = 1,83 \text{ OK}$$



The working out of the limits can cause irreversible damages and voids the warranty.

Check with amperometric pliers the operating of the compressor carter heating. Before proceeding with the start-up, leave the unit powered with stopped compressors for some hours.

6 - START-UP

6.6 COMPRESSOR CRANKCASE RESISTANCES

Connect the oil resistances on the compressor crankcase at least 8 hours before the compressor is to be started :

- at the first unit start-up
 - after each prolonged period of inactivity
1. Supply the resistances switching off the unit isolator switch.
 2. To make sure that the resistances are working, check the power input .
 3. At start-up the compressor crank-case temperature on the lower side must be higher at least of 10°C than the outside temperature.

Do not start the compressor with the crankcase oil below operating temperature.

6.7 VOLTAGES

Check that the air and water temperatures are included in the operating limits. Refer to "Control" section for the indications on the control system.

Start-up the unit.

With operating unit, i.e. in stable conditions and next to the operating ones, check:

- supply voltage
- total absorption of the unit
- absorption of the single electric loads

6.8 REMOTE CONTROLS

- Check that the remote controls (ON-OFF etc) are connected and, if necessary, enabled with the respective parameters as indicated in the ELECTRICAL CONNECTIONS section.
- Check that probes and optional components are connected and enabled with the respective parameters (ELECTRICAL CONNECTIONS section and following pages)

6.9 EVAPORATOR WATER FLOW-RATE

Check that the difference between the temperature of exchanger return and supply water corresponds to power according to this formula:

unit cooling power (kW) x 860 = Dt (°C) x flow rate (L/h).

The cooling power is shown in the table of the GENERAL TECHNICAL DATA included in this manual, referred to specific conditions, or in the tables on COOLING PERFORMANCE in the TECHNICAL BULLETIN referred to various conditions of use.

Check for water side exchanger pressure drops:

- Determine the water flow rate.
- Measure the difference in pressure between exchanger input and output and compare it with the graph on WATER SIDE EXCHANGER PRESSURE DROPS

The measurement of pressure will be easier if pressure gauges are installed as indicated in the DIAGRAM OF SUGGESTED WATER CONNECTIONS .

6.10 OPERATING AT REDUCED LOAD

The units are equipped with partialization steps and they can, therefore, operate with reduced loads.

However a constant and long operation with reduced load with frequent stop and start-up of the compressor/s can cause serious damages for the lack of oil return.

The above-described operating conditions must be considered **OUT** of standards.

In the event of compressor break, due to the operating in the above-mentioned conditions, the guarantee **WILL NOT BE VALID** and Clivet spa declines any responsibility.

Check periodically the average operating times and the frequency of the compressors starts: approximately the minimum thermal load should be such as to need the operating of a compressor for at least ten minutes.

If the average times are close to this limit, take the proper corrective actions.

6.11 START-UP REPORT

Identifying the operating objective conditions is useful to control the unit over time.

With unit at steady state, i.e. in stable and close-to-work conditions, identify the following data :

- Total voltages and absorptions with unit at full load
- Absorptions of the different electric loads (compressors, fans, pumps etc)
- Temperatures and flows of the different fluids (water, air) both in input and in output from the unit
- Temperature and pressures on the characteristic points of the refrigerating circuit (compressor discharge, liquid, intake)

The measurements must be kept and made available during maintenance interventions.

6.12 CE 97/23 PED DIRECTIVE

97/23 CE PED DIRECTIVE gives instructions for installers, users and maintenance technicians as well. Refer to local actuation norms :

Briefly and as an example, see the following :

- COMPULSORY VERIFICATION OF THE FIRST INSTALLATION:
only for units assembled on the installer's building site (for ex. Condensing circuit + direct expansion unit)
- CERTIFICATION OF SETTING IN SERVICE:
for all the units
- PERIODICAL VERIFICATIONS:
to be executed with the frequency indicated by the Manufacturer (see the MAINTENANCE INSPECTIONS paragraph

7 - START-UP

CLIMATICA TExt

Only if P0053: En Climatiga ≠ 0

The setpoint defined by the temperature curve is shown at status S0010: ActualSptTExt

P0265:CSptLow Set Point → AirAtSptLowC

P0266:AirAtSptLowC TEXT → SptLowC

P0267:CSptHigh Set Point → AirAtSptHigC

P0268:AirAtSptHigC TEXT → SptHigC

Eg 1:

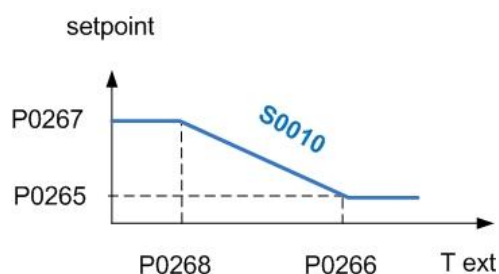

Eg 2:

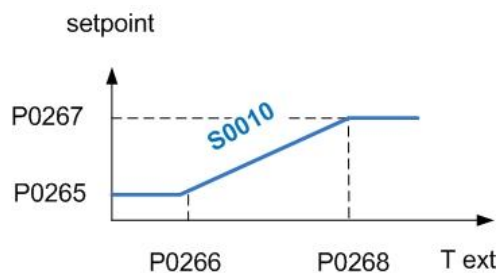

DemandLimit^{pwd}

It is possible to limit the absorbed electric power with an external signal 0-10 Vcc.

The higher the signal is, the lower the number of compressors available to meet the thermal need .

Only if P0050:En DemandLimit ≠ 0

P0009:set demand limit Parameter setting of the value % of demand limit

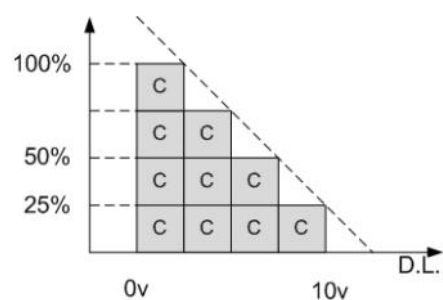

Water Reset^{pwd}

Only if P0051: En WaterReset ≠ 0

The water reset correction affects the setpoint defined by the Climate curve TExt (actual setpoint).

The setpoint is shown at status S0011: ActualSptWR

P0281:MaxCWRC Maximum correction to be applied to the setpoint

P0283:SWRMaxC Value of the WR control signal corresponding to the correction of the set COOL equal to the parameter P281

P0285:SWRMinC Value of the WR control signal corresponding to the correction of the set COOL equal to 0

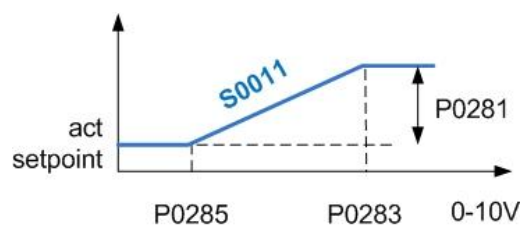

6 - START-UP

6.13 ECOSHARE

If there are more units connected in a local network set the mode of operation

MODE A

Every unit manages its own compressors according to the setpoint.

Every unit optimizes its cooling circuits.

Pumps always active, even with compressor stopped.

P0343 = 0

P0344 > 0 °C

setpoint 1 > setpoint 2 > setpoint 3

or

setpoint 1 < setpoint 2 < setpoint 3

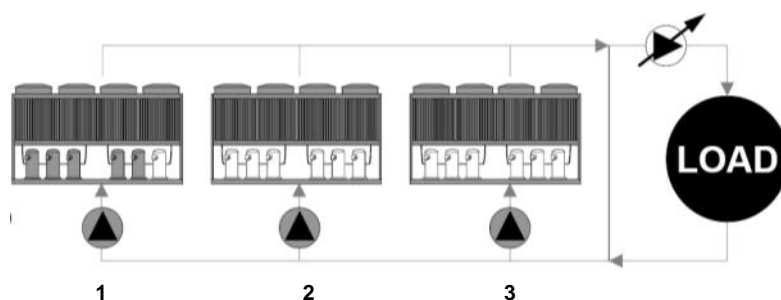

MODE B

The master manages the single cooling.

The master optimizes individual refrigerant circuits.

Pumps always active, even with compressor stopped.

P0343 = 1

P0344 = 0 °C

setpoint 1 = setpoint 2 = setpoint 3

plus: optimal H2O temperature control

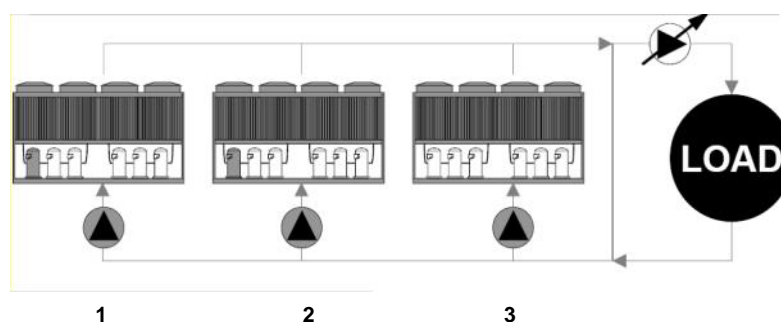

MODE C

The master manages the single cooling.

The master optimizes individual refrigerant circuits.

Active pumps only with active compressors.

P0343 = 2

P0344 = 0 °C

setpoint 1 = setpoint 2 = setpoint 3

plus: minimum pumps consumption

need balanced system (t1 = t2 = t3)

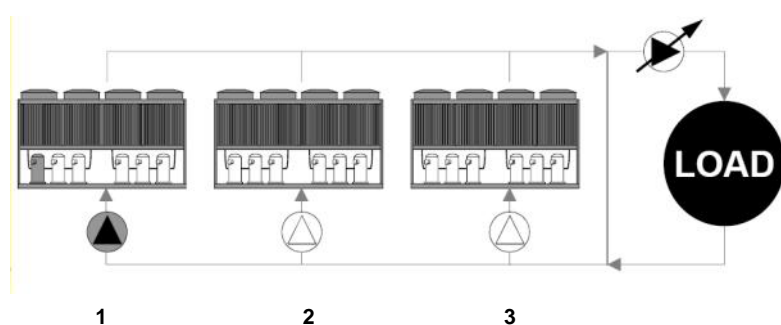

Id		Description
P0340:	Address unit	ProcessBus address unit
P0341:	Unit network	Number of network-connected units including the master
P0342:	Standby unit	Number of units kept in standby
P0343:	TypeRegMS	Operation mode : 0=mode A; 1=mode B; 2=mode C
P0344:	Offset Trm MS	Temperature Offset the master sum or subtract, depending on the way you set, in order of priority, to the set point of the slave.

7 - CONTROL

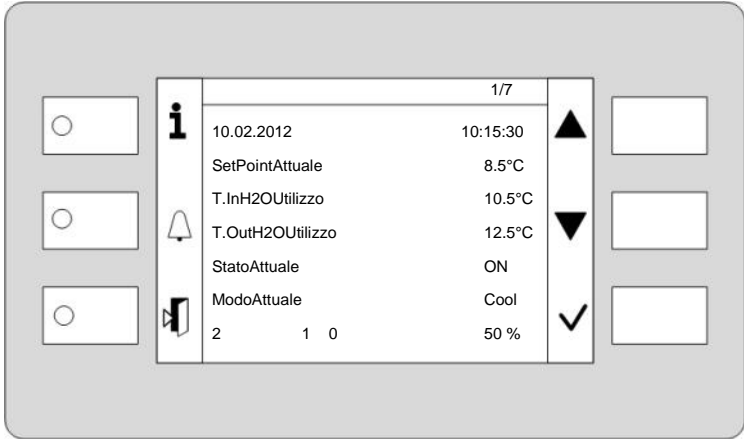







The screenshot shows a control panel interface with a central display area. On the left, there are three circular indicators. The display shows the following information:

- 1/7 (Page indicator)
- 10.02.2012 (Date)
- 10:15:30 (Time)
- SetPointAttuale: 8.5°C
- T.InH2OUtilizzo: 10.5°C
- T.OutH2OUtilizzo: 12.5°C
- StatoAttuale: ON
- ModoAttuale: Cool
- 2 1 0 (Compressor status)
- 50% (Power requirement)

Navigation arrows (up, down, confirm) are visible on the right side of the display area.









Function keys

-  Main menu
-  Alarm display
-  Exit
Previous level
Keyboard settings
-  Up
Increases value
-  Down
Decreases value
-  Confirm
Password

7.1 DISPLAY MEANING

ActualSetPoint	temperature setting	2	installed compressors
T.InH2OUtilitySide	water inlet temperature utility side	3	1 - 0 Compressors ON
T.OutH2OUtilitySide	water outlet temperature utility side		example : circuit 1 = 1 compr. On circuit 2 = 0 compr. On
ActualState	On / off / eco / pmp On		
ActualMode	Cool : water cooling	50%	required power
	Heat : water heating - NOT USED		

7.2 COMMON OPERATIONS

ON, OFF, ECO	  	main menu → cmd local status → scegliere OFF - ECO ON - PUMP ON
change MODE	  	main menu → cmd local mode → select COOL - HEAT (NOT USED)
change SETPOINT	  	main menu → unit parameters → setpoint

7 - CONTROL

7.3 MAIN MENU

Select



Main index	
Cmd Local state	On
Cmd Local mode	Cool
Unit stata	
Unit parameters	
Scheduler	

Select



Main index	
Cmd Local state	On
Cmd Local mode	Cool
Unit stata	
Unit parameters	
Scheduler	

Confirm



Cmd Local state	OFF
	ECO
	ON
	Pmp ON

Cmd Local mode	Cool
	Heat not used

Unit Stata	General
	Circuit Circuit 1 *
	Thermostatic Circuit 1 *
	Recovery Circuit 1 *
	Hydronic Hydronic stata
	Master Slave Stati Master Slave

Parameters Unit	SetPoint
------------------------	----------

Scheduler	Scheduler
------------------	-----------

User settings	Date and hour Language selection
----------------------	-------------------------------------

Local state
 ECO : recurrent pump ON-OFF;
 compressors keep water system at setpoint
 ECO
 Pmp ON : pump ON, compressors OFF

Unit Stata
 Input, output functioning variables.
 See next pages tables
 * Circuits number depend on unit's series .
 The menu is repeated for each refrigerant circuit (circuit: circuit1, circuit2,.....;thermostatic: circuit1, circuit2,.....)

Menu Setpoint
 P0001:SetPoint Cool - Cooling
 P0002:SetPoint Heat - heating NOT USED
 P0003:2°SetPoint Cool - enable by remote switch
 P0004:2°SetPoint Heat NOT USED
 P0005:SetPoint ECOCool
 P0006:SetPoint ECOHeat NOT USED
 P0007:SetPointRec - recovery

Schedule
 See next page.

7 - CONTROL



7.4 SCHEDULER



It is possible to set 6 events (Off, Eco, On, Recirculating) for each week day.



Scheduler must be enabled:



display : actual value = On

pag **xy** : unit parameters service-maintenance, P0500=1

Select		<p style="text-align: center;">Main index</p> <p>Cmd Local state On</p> <p>Cmd Local mode Cool</p> <p>Unit stata</p> <p>Unit parameters</p> <p>Scheduler</p>
Confirm		

Select		<p style="text-align: center;">Main index</p> <p>Actual value On</p> <p>01 : Monday Off</p>
Confirm		<p>01 : Tuesday Off</p> <p>01 : Wednesday Off</p> <p>01 : Thursday Off</p> <p>01 : Friday Off</p>

Select		<p style="text-align: center;">d01 : Monday</p> <p>Scheduled day Active</p> <p>Time 1 00:00</p>
Confirm		<p>Value 1 ECO</p> <p>Time 2 5:00</p>
Setting		<p>Value 2 ON</p> <p>Time 3 17:00</p>
Exit		<p>Value 3 ECO</p> <p>Time 4 20:00</p> <p>Value 4 OFF</p>

Select		<p style="text-align: center;">d01 : Monday</p> <p>Scheduled day Active</p> <p>Time 1 xx:yy</p>
Confirm		<p>Value 1 Eco</p>
Setting		<p>Time 2</p> <p>Value 2</p>
Exit		<p>Time 3</p> <p>Value 3</p>

7 - CONTROL

7.5 TO VISUALIZE ALARM IN PROGRESS

 Before resetting an alarm identify and remove its cause.
Repeated resets can cause irreversible damage.

Press  **alarm log detail**

+ eE001 : Monitore fase : Fault

1 Critico (A)

14.02.2012 11.30.10

Press  **alarm list**

Reset Passivo 1

+ eE001 : Monitore fase : Fault

Press  **alarm log**

Reset Passivo 10

+ eE001 : **Monitore fase : Fault**

- EE003 : Guasto P1 Util : Ok

+ EE003 : Guasto P1 Util : Fault

- eE001 : Monitore fase : Fault = active alarm
- - EE003 : Guasto P1 Util : Ok = resetted alarm

RESET ALARM

Press  **alarm log detail**

+ eE001 : Monitore fase : Fault

1 Critico (A)

14.02.2012 11.30.10

Press  **alarm list**

Reset Passivo 1

+ eE001 : Monitore fase : Fault

Press  **alarm log**

Reset Passivo 10

+ eE001 : **Monitore fase : Fault**

- EE003 : Guasto P1 Util : Ok

+ EE003 : Guasto P1 Util : Fault

.....

Slide  **Password**

Press 3 sec. 

Enter password:
Maintenance
Developer

Password

0 - - -

Confirm 

Press  **alarm list**

Reset Passivo 1

+ eE001 : Monitore fase : Fault

Confirm 

Select  **Passivo**

Confirm  **Attivo**

Select  **alarm list**

Reset Passivo 0

Uscita :
Premere 3c.  **password management**

Select  **Log off**

Confirm  Cambia PSS user
Cambia PSS service
Cambia PSS manufacturer

7 - CONTROL

ALARM LOG RESET

Press



alarm log

Reset **Passivo 10**

+ eE001 : Monitore fase : Fault
 - EE003 : Guasto P1 Util : Ok
 + EE003 : Guasto P1 Util : Fault

Press 3 sec.



10.02.2012	10:15:30
SetPointAttuale	8.5°C
T.InH2Outilizzo	10.5°C
T.OutH2Outilizzo	12.5°C
StatoAttuale	ON
ModoAttuale	Cool
12 1 1	100%

Press 3 sec.



Password

Password

0 - - -

Select



password management

Log off

Cambia PSS utente
 Cambia PSS service
 Cambia PSS costruttore

Insert password:
 Maintenance
 Manufacturer

Confirm



Confirm



Press



alarm log

Reset **Passivo 10**

+ eE001 : Monitore fase : Fault
 - EE003 : Guasto P1 Util : Ok
 + EE003 : Guasto P1 Util : Fault

7.6 KEYBOARD SETTINGS

Select



Alarm cnf

AlarmSnapshot 0

Lista allarmi :

Ordinamento 1 Ora

Ordinamento 2 Ora

Ordine decrescente Passive

Storico allarmi :

Reset

Press 3 sec



HMI settings

local connection

Confirm



Select



Confirm



Select



Execute

exit :



HMI settings

V9.08 B0024

Backlight color Blue

Backlight turn off time 0

Contrast 60

Brightness 100

Firmware Update No

Confirm



Select



Allarmi cnf

AlarmSnapshot 0

Lista allarmi :

Ordinamento 1 Ora

Ordinamento 2 Ora

Ordine decrescente Passive

Storico allarmi :

Reset

To exit :

Select



Confirm



HMI settings

local connection

7 - CONTROL

ALARMS - TAB 1

code	description	description	t.i.	module	input	t.a.
eE001	phase monitor	Phase monitor	DI	687 central	T13 DL1	A/M
EE003	pump 1 faulty	Pump 1 faulty	DI	687 central	T13 DL2	M
EE004	pump 2 faulty	Pump 2 faulty	DI	687 central	T4 D1	M
EE005	pump 3 faulty	Pump 3 faulty	DI	687 central	T13 DL2	M
ee010	master offline	Master Offline - Master Slave network enabled				A
ee011	unit 2 in alarm	Unit 2 in alarm - Master Slave network enabled				A
ee012	unit 2 offline	Unit 2 OffLine - Master Slave network enabled				A
ee013	unit 3 in alarm	Unit 3 in alarm - Master Slave network enabled				A
ee014	unit 3 offline	Unit 3 OffLine - Master Slave network enabled				A
ee015	unit 4 in alarm	Unit 4 in alarm - Master Slave network enabled				A
ee016	unit 4 offline	Unit 4 OffLine - Master Slave network enabled				A
ee017	unit 5 in alarm	Unit 5 in alarm - Master Slave network enabled				A
ee018	unit 5 offline	Unit 5 OffLine - Master Slave network enabled				A
ee019	unit 6 in alarm	Unit 6 in alarm - Master Slave network enabled				A
ee020	unit 6 offline	Unit 6 OffLine - Master Slave network enabled				A
ee021	unit 7 in alarm	Unit 7 in alarm - Master Slave network enabled				A
ee022	unit 7 offline	Unit 7 OffLine - Master Slave network enabled				A
EE023	Pump 1 overload	Pump 1 thermal protection	DI	965 hydronic	T1 X4	M
EE024	Pump 2 overload	Pump 2 thermal protection	DI	965 hydronic	T1 X5	M

The alarm code identifies the concerned circuit:

Es: ee 1 01 :TimeOutModCirc = circuit 1
 ee 2 01 :TimeOutModCirc = circuit 2

The number of refrigerant circuits depends on series and size of the unit.

t.i. input type:

DI digital input
 AI analogic input

module:

687 = main module
 985 = circuit module
 94U = thermostatic driver module

input:

connector number: T1, T2, T3...
 PIN code: X1, X2, Q13, DO1....

t.a. alarm type:

A automatic reset
 M manual reset
 A/M automatic reset , after N alarm → manual reset

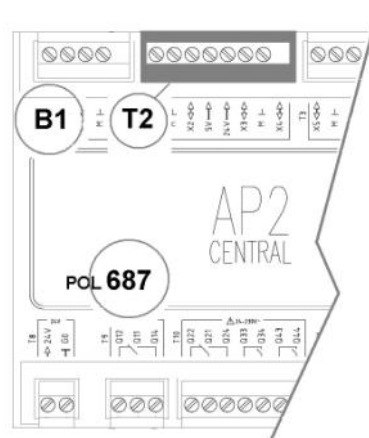

7 - CONTROL

ALARMS - TAB 2

code	description	description	t.i.	module	input	t.a.
EE025	Pump 3 overload	Pump 3 thermal protection	DI	965 hydronic	T1 X6	A
EE026	Inverter overload	Inverter overload	DI	965 hydronic	T5 DL1	A
ee027	water IN temp	Water inlet temperature probe faulty	AI	687 central	T1 B1	A
ee028	Water OUT temp	Water outlet temperature probe faulty	AI	687 central	T1 B2	A
ee029	External air temp	External air temperature probe faulty	AI	687 central	T1 B3	A
ee030	Demand Limit	Signal logoff or short circuit	AI	687 central	T2 X1	A
ee031	WaterReset	Signal logoff or short circuit	AI	687 central	T2 X2	A
ee032:	External Humidity probe	External Humidity probe faulty	AI	687 central	T2 X3	A
ee033:	Cabinet temperature	Cabinet temperature probe faulty	AI	687 central	T2 X4	A
ee034:	Timeout hydronic module	Logoff Hydronic module		peripheral bus		A
ee101:	Timeout circuit module	Logoff circuit 1 module		peripheral bus		A
ee102:	Timeout comm. Driver	Logoff driver 1 module		peripheral bus		A
ee103:	Timeout comm. Module rec	Logoff recovery module		peripheral bus		A
ee104:	EEV blocked	Driver 1 blocked		94U driver		A
EE106:	Comp 1 protections	Compressor 1 thermal protection	DI	985 circuit 1	T4 D1	M
EE107:	Comp 2 protections	Compressor 2 thermal protection	DI	985 circuit 1	T4 D2	M
EE108:	Comp 3 protections	Compressor 3 thermal protection	DI	985 circuit 1	T4 D3	M
EE118:	source side protection	Source side protection	DI	985 circuit 1	T9 DL2	M
ee122:	discharge temp. C1	Faulty probe - discharge temperature compressor 1	AI	985 circuit 1	T1 B1	A
ee123:	discharge temp. C2	Faulty probe - discharge temperature compressor 2	AI	985 circuit 1	T1 B2	A
ee124:	discharge temp. C3	Faulty probe - discharge temperature compressor 3	AI	985 circuit 1	T2 X2	A
ee125:	source1 temp.	Faulty probe - source 1 temperature	AI	985 circuit 1	T1 B3	A
ee126:	source2 temp.	Faulty probe - source 2 temperature	AI	985 circuit 1	T2 X1	A
ee127:	Suction temperature	Faulty probe - Suction temperature	AI	94U driver	T2 X2	A
ee128:	discharge pressure	Faulty probe - discharge pressure	AI	985 circuit 1	T2 X3	A
ee129:	suction pressure	Faulty probe - suction pressure	AI	94U driver	T1 X1	A
ee130:	Rec. Gas temperature	Faulty probe - Recovery gas temperature	AI	965 recovery	T1 X1	A
ee131:	Rec. Pressure	Faulty probe - Recovery gas pressure	AI	965 recovery	T2 X7	A
ee132:	Water In rec. Temp.	Faulty probe - Water recovery inlet	AI	965 recovery	T1 X2	A
ee133:	Water out rec. Temp.	Faulty probe - Water recovery outlet	AI	965 recovery	T1 X3	A
ee135:	Bsp 985 wrong	Bios wrong version		985 circuit 1		A
ff105:	min overheating	Low overheating C1				A
fF109:	Low pressure from DI	Low pressure from digital input	DI	985 circuit 1	T3 X7	A/M

7 - CONTROL

ALARMS - TAB 3

code	description	description	t.i.	module	input	t.a.
ff110:	Pre-low pressure cool	Pre-alarm - low pressure COOL mode				A
ff111:	Pre-low pressure heat	Pre-alarm - low pressure HEAT mode				A
fF112:	low pressure from AI	Low pressure from analogic input	AI	94U driver	T1 X1	A/M
fF113:	high pressure from DI	High pressure from digital input	DI	985 circuit 1	T3 X8	A/M
ff114:	pre-high pressure	Pre-alarm - high pressure				A
fF115:	high pressure from AI	High pressure from analogic input	AI	985 circuit 1	T2 X3	A/M
ff116:	pre-max compr ratio	Pre-alarm max. compression ratio (high pressure / low pressure)				A
fF117:	min compr. Ratio	Min. compression ratio (high pressure / low pressure)				A/M
FF119:	max compr. Ratio	Alarm max. compression ratio (high pressure / low pressure)				M
FF134:	VaccumCirc	Empty circuit	AI	94U driver	T1 X1	M
ii002:	water pressure	Low water pressure	DI	687 central	T5 DU1	A/M
ii006:	flow switch utility side	Flow switch utility side	DI	687 central	T3 X8	A/M
II007:	freeze alarm	Freeze alarm utility side				M
ii008:	pumps antifreeze alarm	Utility side pumps On for antifreeze alarm				A
II009:	inconsistent deltaT across the exchanger	COOL: Outlet temperature higher than inlet temperature HEAT: Inlet temperature higher than outlet temperature				A
ii120:	flow on source side	Flow switch source side	DI	985 circuit 1	T2 X4	A/M
II121:	freeze on source side	Freeze alarm source side				A

STATA

The stata code identifies the concerned circuit:

Es: **S 1** 100:CMP1 compressor1 starts = circuit 1
 S 2 100:CMP1 compressor1 starts = circuit 2

The number of refrigerant circuits depends on series and size of the unit.

Eg:

AI-687 T.IN H2Outil_B1 Inlet water temperature

AI analogic input
 687 main control module
 B1 PIN

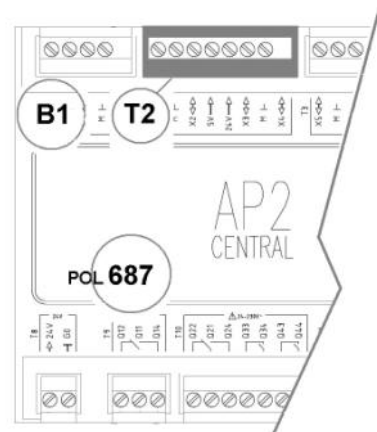

7 - CONTROL

GENERAL STATA E CENTRAL MODULE

code	description	description
AI-687	Temp.In H2O userside_B1	Inlet water temperature utility side
AI-687	Temp.Out H2O userside_B1	Outlet water temperature utility side
AI-687	Ext.Air temp_B3	External air temperature
AI-687	S.DemandLimit_X1	Demand limit signal
AI-687	S.WaterReset_X2	Water reset signal
AI-687	RHExt_X3	External humidity
AI-687	EI.CabinetTemp_X4	Cabinet temperature
AO-687	%FreeCooling_X5	% value external freecooling signal
DI-687	Sel.SetPoint_DU2	2nd setpoint status : 0=1°set 1=2°Set
DI-687	SystemPressure_DU1	System pressure probe status: 0=OK 1=Fault
DI-687	FlowUser_X8	Flow switch utility side status: 0=OK 1=Fault
DI-687	RemON-OFF_X7	Unit status: 0=OFF 1=On
DI-687	Heat/CoolRem_X6	Unit mode: 0=Heat 1=Cool
DI-687	PhaseMonitor_DL1	Phase monitor : 0=OK 1=Fault
DI-687	OvIP1Util_D2	Pump1 thermal protection utility side: 0=OK 1=Fault
DI-687	OvIP2Util_D1	Pump2 thermal protection utility side: 0=OK 1=Fault
DI-687	OvIP3Util_DL2	Pump3 thermal protection utility side: 0=OK 1=Fault
DO-687	EI.CabinetFAN_DO1	Cabinet fan : 0=Off 1=On
DO-687	EI.CabinetHEAT_DO2	Cabinet heating : 0=Off 1=On
DO-687	UnitMode_Q1	Unit mode digital output (N.O. open=Cool N.O. closed=Heat): 0=Cool 1=Heat
DO-687	Cumul.Alarm_Q2	Cumulative alarm (N.O. open=All OFF N.O. closed=All ON): 0=Off 1=On
DO-687	CmdP1User_Q3	Command pump 1 utility side : 0=Off 1=On
DO-687	CmdP2User_Q4	Command pump 2 utility side : 0=Off 1=On
DO-687	CmdP3User_Q5	Command pump 3 utility side : 0=Off 1=On
DO-687	OpenYV_FC_Q7	Free-cooling opening command closed FC = ON: 0=Off 1=On
DO-687	CloseYV_FC_Q8	Free-cooling closing command closed FC = OFF: 0=Off 1=On
DO-687	AntifreezeHeater_Q6	Antifreeze heater : 0=Off 1=On
S0001	StartsP1User	Starts pump1 utility side
S0002	StartsP2User	Starts pump2 utility side
S0003	StartsP3User	Starts pump3 utility side
S0004	Pump1 running hours	Hours pump1 utility side
S0005	Pump2 running hours	Hours pump2 utility side
S0006	Pump3 running hours	Hours pump3 utility side
S0007	Antifreeze heat.	Antifreeze heater 0=Off 1=On
S0008	pump in antifreeze alarm	Pump ON by antifreeze alarm: 0=Off 1=On
S0009	recovery	Recovery 0=Off 1=On
S0010	ActualSptText	Actual setpoint by external temperature
S0011	ActualSptWR	Actual setpoint by Water Reset
S0012	StatusFreeCooling	FreeCooling 0=Off 1=On
S0013	GenWarning	0=Off 1=On
S0014	GenBlock	0=Off 1=On
S0015	NCompOnUnit	Active compressors

7 - CONTROL

CIRCUIT 1 STATA - TAB1

code	description	description
AI-94U	SuctionTemp_X2	Suction temperature
AI-94U	SuctionPressureX1	Suction pressure
AI-985	DischargeTC1_B1	Compressor 1 discharge temperature
AI-985	DischargeTC2_B2	Compressor 2 discharge temperature
AI-985	DischargeTC3_X2	Compressor 3 discharge temperature
AI-985	SourceTemp1_B3	Source temperature (air source unit = Probe on source coil. Water source unit = Probe on source inlet)
AI-985	SourceTemp2_X1	Source temperature 2 (air source unit = Probe 2 on source coil. Water source unit = Probe 2 on source inlet)
AI-985	DischargePressure_X3	High pressure probe
AO-985	%Cmd Cmp_X5	Compressor modulating signal control
AO-985	%Cmd Source_X6	Source modulating signal control
DI-985	Source WaterFlow_X4	Source water flow (water source unit only) : 0=Fault 1=OK
DI-985	LP Pressure switch_X7	Low pressure switch : 0=Fault 1=OK
DI-985	Ovl Inverter_DL1	Inverter compressor overload : 0=Fault 1=OK
DI-985	HP Pressure switch_X8	High pressure switch : 0=Fault 1=OK
DI-985	Ovl Source_DL2	Source thermal protection : 0=Fault 1=OK
DI-985	Ovl Cmp1_D1	Thermal protection compressor 1: 0=Fault 1=OK
DI-985	Ovl Cmp2_D2	Thermal protection compressor 2: 0=Fault 1=OK
DI-985	Ovl Cmp3_D3	Thermal protection compressor 3: 0=Fault 1=OK
DI-985	Diff.PressureOilScrew_D2	Differential oil pressure (screw compressor only): 0=Fault 1=OK
DI-985	EnCircScrew_D3	Enabling circuit input (screw compressor only): 0=Fault 1=OK
DO-985	Cmd Cmp1_Q2	Compressor 1 command : 0=Off 1=On
DO-985	Cmd Cmp2_Q3	Compressor 2 command : 0=Off 1=On
DO-985	Cmd Cmp3_Q4	Compressor 3 command : 0=Off 1=On
DO-985	Cmd Source_Q1	Source command: 0=Off 1=On
DO-985	Cmd Inj.Cmp1_Q5	Compressor 1 liquid injection valve : 0=Off 1=On
DO-985	Cmd Inj.Cmp2_Q7	Compressor 2 liquid injection valve : 0=Off 1=On : 0=Off 1=On
DO-985	Cmd Inj.Cmp3_Q8	Compressor 3 liquid injection valve : 0=Off 1=On : 0=Off 1=On
DO-985	Cmd YV4 reversingValve_Q6	Reversing valve : 0=Off 1=On
DO-985	Cmd Digital_DO2	Pulsating valve PWM compressors : 0=Off 1=On
DO-985	Cmd KMLine_Q2	Line contactor (screw compressor only): 0=Off 1=On
DO-985	Cmd KMPW1_Q3	1st winding / Star contactor Q3:DO-985 (screw compressor only): 0=Off 1=On
DO-985	Cmd KMPW2_Q4	2nd winding / triangle contactor (screw compressor only) : 0=Off 1=On
DO-985	Cmd YV25%_Q7	Start stop valve YV25% (screw compressor only): 0=Off 1=On
DO-985	Cmd YV75%_Q8	Valve YV75%(CR3_Bitzer) (14_Refcomp) (screw compressor only): 0=Off 1=On
DO-985	Cmd YVUP_DO1	Increase power valve (CR4_Bitzer) (16_RefComp) (screw compressor only): 0=Off 1=On

7 - CONTROL

CIRCUIT 1 STATA - TAB 2

code	description	description
DO-985	Cmd YVDW_DO2	Decreasing power valve (CR2_Bitzer) (15_RefComp) (screw compressor only): 0=Off 1=On
S1100	CMP1 starts	Compressor 1 starts
S1101	CMP2 starts	Compressor 2 starts
S1102	CMP3 starts	Compressor 3 starts
S1103	StartsScrew	Screw compressor starts
S1104	Source starts	Source starts
S1105	Hours Comp.1	Hours Compressor 1
S1106	Hours Comp.2	Hours Compressor 2
S1107	Hours Comp.3	Hours Compressor 3
S1108	HoursScrew	Hours screw compressor
S1109	HoursSource	Hours Source
S1110	Total steps	Total steps engaged on the circuit
S1111	Comp.1 status	Compressor 1: 0=free 1=on 2=timing 3=Disabled
S1112	Comp.2 status	Compressor 2: 0=free 1=on 2=timing 3=Disabled
S1113	Comp.3 status	Compressor 3: 0=free 1=on 2=timing 3=Disabled
S1114	Current cap.	Current capacity engaged on the circuit
S1115	Requested cap.	Requested capacity on the circuit
S1116	Pressure ratio	Pressure ratio (1+Hp/1+LP)
S1117	FANPreAlarm	Max. fan pre-alarm 0=Off 1=On
S1118	Defrost delay	Actual value defrost counting (0= defrost starting)
S1119	Defrost status	Defrost status : 0=Defrost Off, 1=Defrost ON
S1120	HWErr	Hardware fault POL94U module : handling possible
S1121	BlckingHWErr	Hardware fault POL94U module handling impossible
S1122	FailSafeSta	Safe status : 0=Off 1=On
S1123	UPSNotAval	UPS faulty : 0=Off 1=On
S1124	CircWarning	Circuit warning
S1125	CircBlock	Circuit alarm
S1126	ThTDischarge	Estimated discharge temperature

7 - CONTROL

THERMOSTATIC C1 STATA

code	description	description
S1200	SHSpOp	Overheating SetPoint
S1201	AlCalSuctSprHtP	Actual Overheating SetPoint
S1202	ECVState	0 = Idle 1 = ECVAlarm 2 = FailSafe 3 = Referencing 4 = Positioning 5 = Positioned 6 = ECVWaiting 7 = FastClosing
S1203	EEV:SH_Limiter	Max. opening valve
S1204	EEV:LET_Limiter	Min. opening valve
S1205	EEVMode	0=Idle (motor off) 1=Init (valve closed) 2=Manual 3=Control
S1206	Prepos	Thermostatic requested positioning
S1207	ECVSetPos	% Opening valve if EEVMod = Manual
S1208	ECVMode	0 = Idle 1 = Init 2 = Position 3 = FastClose
S1209	SHPIDOut	% Output PID value
S1210	EEVStatus	0 - Closed (Ready) 1 - StartUpPositioning 2 - StartUpPositioned 3 - SuperHeat 4 - Prepositioning 5 - MET 6 - LET 7 - Closing 8 - PumpDown 9 - DangAlarm 10 - PumpDownStartUp 11 - ECVAlarm 12 - MinSHLmtr 13 - WaitValveClose 255 - Warning
S1211	SetPosSteps	Number of control steps that must reach the valve to adjust the superheat
S1212	SetPos%	Valve % opening command to adjust the superheat
S1213	Pol94xCommOK	Connection Status of the module POL94U : 0=NotOK 1=OK
S1214	ActPos%	Actual position valve EEV
S1215	ActPosSteps	Actual steps number valve EEV
S1216	ECVMode	0 = Idle 1 = Init 2 = Position 3 = FastClose.
S1217	ECVState	0 = Idle 1 = ECVAlarm 2 = FailSafe 3 = Referencing 4 = Positioning 5 = Positioned 6 = ECVWaiting 7 = FastClosing

RECOVERY CIRCUIT 1 STATA

code	description	description
AI-965	P.OutRec_X7	Pressure value recovery circuit
AI-965	T.InH2ORec_X2	Recovery inlet water temperature
AI-965	T.OutH2ORec_X3	Recovery outlet water temperature
AI-965	T.OutGasRec_X1	Recovery gas outlet temperature
AO-965	%CmdPmpRec_X8	% 0-10vcc signal value recovery variable pump
DI-965	EnableRec_X4	Enabling recovery input : 0=Fault 1=OK
DI-965	Ovl PmpRec_X5	Recovery thermal protection pump 0=Fault 1=OK
DI-965	FlowRec_X6	Flow recovery 0=Fault 1=OK
DI-965	SystemPress.Recovery_DL1	System pressure probe: 0=Fault 1=OK
DO-965	YV1Rec_DO1	Command valve YV1 0=Off 1=On
DO-965	YV2Rec_DO2	Command valve YV2 0=Off 1=On
DO-965	YV3Rec_Q1	Command valve YV3 0=Off 1=On
DO-965	YV4Rec_Q2	Command valve YV4 0=Off 1=On
DO-965	YV5Rec_Q3	Command valve YV5 0=Off 1=On
DO-965	PmpRec_Q4	Recovery pump command 0=Off 1=On

7 - CONTROL

STATI MASTER SLAVE

code	description	description
S0600	SetPoint Unit1	Value accessible from the display of the unit machine network master. Working setpoint master unit (Address 1 on periferibus)
S0601	SetPoint Unit2	Value accessible from the display of the unit machine network master. Working setpoint unit 2 (Address 2 on periferibus)
S0602	SetPoint Unit3	Value accessible from the display of the unit machine network master. Working setpoint unit 3 (Address 3 on periferibus)
S0603	SetPoint Unit4	Value accessible from the display of the unit machine network master. Working setpoint unit 4 (Address 4 on periferibus)
S0604	SetPoint Unit5	Value accessible from the display of the unit machine network master. Working setpoint unit 5 (Address 5 on periferibus)
S0605	SetPoint Unit6	Value accessible from the display of the unit machine network master. Working setpoint unit 6 (Address 6 on periferibus)
S0606:	SetPoint Unit7	Value accessible from the display of the unit machine network master. Working setpoint unit 7 (Address 7 on periferibus)
S0607:	StatusUnit1	Value accessible from the display of the unit machine network master. Status master unit 7 0=Off 1=Eco 2=On 3=PmpOn
S0608:	StatusUnit2	Value accessible from the display of the unit machine network master. Status unit 2 0=Off 1=Eco 2=On 3=PmpOn
S0609:	StatusUnit3	Value accessible from the display of the unit machine network master. Status unit 3 0=Off 1=Eco 2=On 3=PmpOn
S0610:	StatusUnit4	Value accessible from the display of the unit machine network master. Status unit 4 0=Off 1=Eco 2=On 3=PmpOn
S0611:	StatusUnit5	Value accessible from the display of the unit machine network master. Status unit 5 0=Off 1=Eco 2=On 3=PmpOn
S0612:	StatusUnit6	Value accessible from the display of the unit machine network master. Status unit 6 0=Off 1=Eco 2=On 3=PmpOn
S0613:	StatusUnit7	Value accessible from the display of the unit machine network master. Status unit 7 0=Off 1=Eco 2=On 3=PmpOn

7 - CONTROL

HYDRONIC MODULE STATA

code	description	description
AO-965	%CmdInverter_X7	% value inverter command signal
DI-965	OvIP1.Hid_X4	Pump 1 overload 1 : 0=OK 1=Fault
DI-965	OvIP2.Hid_X5	Pump 2 overload : 0=OK 1=Fault
DI-965	OvIP3.Hid_X6	Pump 3 overload : 0=OK 1=Fault
DI-965	OvInv.Hid_DL1	Inverter overload : 0=OK 1=Fault
DO-965	CmdP1.Hid_DO1	Pump 1 command : 0=Off 1=On
DO-965	CmdP1Inv.Hid_Q2	Pump 1 inverter command : 0=Off 1=On
DO-965	CmdP2.Hid_DO2	Pump 2 command : 0=Off 1=On
DO-965	CmdP2Inv.Hid_Q3	Pump 2 inverter command : 0=Off 1=On
DO-965	CmdP3.Hid_Q1	Pump 3 command : 0=Off 1=On
DO-965	ComdP3Inv.Hid_Q4	Pump 3 inverter command : 0=Off 1=On
DO-965	CmdInverter:X8	Hydronic inverter command: 0=Off 1=On
S0500	StartsP1Hidro	Pump 1 starts
S0501	StartsP2Hidro	Pump 2 starts
S0502	StartsP3Hidro	Pump 3 starts
S0503	HoursP1.Hid	Pump hours 1
S0504	HoursP2.Hid	Pump hours 2
S0505	HoursP3.Hid	Pump hours 3
S0506	HoursInverter.Hid	Hydroni module inverter hours

ENERGY METER STATA

S0720:	U12	L1 - L2 voltage
S0721:	U23	L2 - L3 voltage
S0722:	U31	L1 - L3 voltage
S0723:	Freq	Frequency
S0724:	IL1	L1 current
S0725:	IL2	L2 current
S0726:	IL3	L3 current
S0727:	Ptotale	Current active power
S0728:	Cosfi	Total power factor
S0729:	Energy	Active energy totalized
S0730:	THD-U12	Sum of harmonic components of voltage between L1 e L2
S0731:	THD-U23	Sum of harmonic components of voltage between L2 e L3
S0732:	THD-U31	Sum of harmonic components of voltage between L3 e L1

7 - CONTROL

P.C. CONNECTION

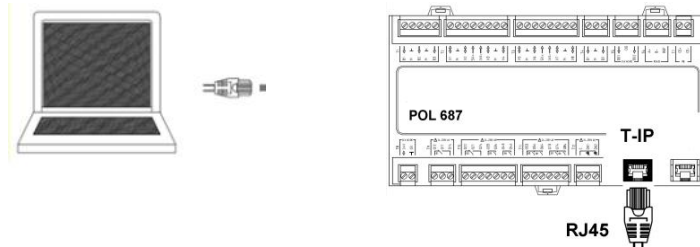

- 1 connect P.C. and main module with LAN cable
- 2 check in the taskbar that the connection is active
- 3 Open **Control panel** and select **Network and sharing center**
- 4 Select **Modify board setting**
- 5 Select **Local area connection (LAN)**
- 6 Select **Internet protocol version 4 (TCP) IPV4** and enter **Property**
- 7 Set the IP address **192.168.1.100**
- 8 Set Subnet mask as **255.255.255.0**
- 9 confirm (**OK**)
- 10 Enter **Start** (Windows button).
- 11 Write the command **cmd** and enter/do it
- 12 Write and run the command **Ping 192.168.1.42**
- 13 if will appear dawn an answer string, the connection is ok
- 14 enter the browser and the address **192.168.1.42**
- 15 Userid = **ADMIN**
- 16 Password = **SBTAdmin!**

8 - MAINTENANCE

CONTROL CHECK LIST

Controls effected onBy Of the Company.....

√		1	6	12
<input type="checkbox"/>	Presence of corrosions			●
<input type="checkbox"/>	Panel fixing			●
<input type="checkbox"/>	Fan fixing		●	
<input type="checkbox"/>	Coil cleaning		●	
<input type="checkbox"/>	Water filter cleaning		●	
<input type="checkbox"/>	Check the exchanger efficiency			●
<input type="checkbox"/>	Circulating pumps		●	
<input type="checkbox"/>	Check of the fixing and the insulation of the power lead		●	
<input type="checkbox"/>	Check of the earthing cable		●	
<input type="checkbox"/>	Electric panel cleaning			●
<input type="checkbox"/>	Capacity contactor status		●	
<input type="checkbox"/>	Termina closing, cable insulation integrity			●
<input type="checkbox"/>	Voltage and phase unbalancing (no load and on-load)		●	
<input type="checkbox"/>	Absorptions of the single electrical loads		●	
<input type="checkbox"/>	Test of the compressor carter resistances		●	
<input type="checkbox"/>	Leak control *			●
<input type="checkbox"/>	Survey of the refrigerant circuit operating parameters		●	
<input type="checkbox"/>	Protective device test : safety valves, pressure switches, thermostats, flow switches etc		●	
<input type="checkbox"/>	Control system test: setpoint, climatic compensations, capacity stepping, water / air flow-rate variations etc		●	
<input type="checkbox"/>	Control device test : alarm signalling, thermometers, probes, pressure gauges etc		●	

Notes / interventions recommended to the owner

* European regulation 303/2008

Refer to the local actuation regulations; in short and just as an indication the regulation order as follow.

Companies and technicians that effect interventions of installation, maintenance/repairs, leak control and recovery must be CERTIFIED as expected by the local regulations.

The leak control must be effected with annual renewal.

8 - MAINTENANCE

8.1 GENERAL

Maintenance must be done by authorized centres or by qualified personnel

The maintenance allows to:

- maintain the unit efficiency
- reduce the deterioration speed to whom every equipment is subject over time
- assemble information and data to understand the state of the unit efficiency and avoid possible damages

8.2 INSPECTIONS FREQUENCY

The inspections should be carried out at least:

- Every year for only the cooling units
- Every six months for the cooling and warming units

The frequency, however, depends on the use.

In the event of frequent use it is recommended to plan inspections at close intervals:

- frequent use (continuous or very intermittent use, near the operating limits, etc)
- critical use (service necessary).

8.3 UNIT BOOKLET

It's advisable to create a unit booklet to take notes of the unit interventions.

In this way it will be easier to adequately note the various interventions and aid any troubleshooting.

Report on the booklet:

- data
- type of intervention effected
- intervention description
- carried out measures etc.

TENSIONS

After switching off the power, wait at least 5 minutes before accessing to the electrical panel or any other electrical component.

Check with a multimeter that there are no residual tensions

8.4 STRUCTURE

Check the condition of the parts making up the structure.

Paint so as to eliminate or reduce oxidation at the points in the unit where this problem may occur.

Check that the panelling is fastened correctly.

Poor fastening may give rise to malfunctions and abnormal noise and vibration.

8.5 WATER FILTER

Check that no impurities prevent the correct passage of water.

8.6 ELECTRIC FANS

Check :

- the fans and the relative protection grids are well fixed
- The fan bearings (evident by noise and anomalous vibrations)
- the terminal protection covers are closed and the cable holders are properly positioned

8.7 COIL

Contact with the exchanger fins can cause cuts.

Wear protective gloves to perform the above described operations.

It is extremely important that the battery gives the maximum thermal exchange; therefore, its surface must be cleaned from dust and deposits. Remove all impurities from the surface.

Using an air pressure gun, clean the aluminum surface of the battery. Be careful to direct the air in the opposite direction of the fan air movement.

Hold the gun parallel to the fins to avoid damages. As an alternative, an aspirator can be used to suck impurities from the air input side.

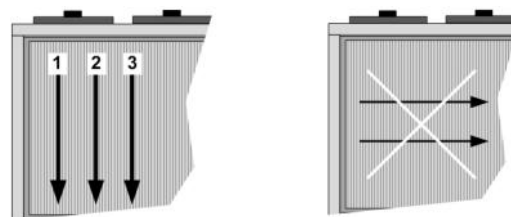

Verify that the aluminum fins are not bent or damaged. In the event of damages, contact the authorized assistance center and get the battery "ironed out" in order to restore the initial condition for an optimal air flow

8.8 WATER EXCHANGER

It is very important for the exchanger to be able to provide the maximum thermal exchange. Therefore, it is essential for the inner surfaces to be clean of dirt and incrustations.

Periodically check the difference between the temperature of the supply water and the condensation temperature. If the difference is greater than 8 °C – 10 °C it is advisable to clean the exchanger.

The clearing must be effected :

- With circulation opposite to the usual one
- With a speed at least 1,5 times higher than the nominal one
- With an appropriate product moderately acid (95% water + 5% phosphoric acid
- After the cleaning rinse with water to inhibit the detergent rests.

8 - MAINTENANCE

8.9 CIRCULATION PUMPS

Verify :

- no leaks
- Bearing status (anomalies are highlighted by abnormal noise and vibration)
- The closing of the terminals cover and the correct positioning of the cable glands.

8.10 PUT A REST

If a long period of inactivity is foreseen:

- Turn off the power to avoid electrical risks or damages by lightning strikes
- drain the water to avoid the risk of frost
- Protect from air exchangers and plant To prevent any oxidation and fouling

1. evacuate the system
2. evacuate the exchanger
Use all the cocks presents
3. Use compressed air to blow the exchanger
4. dry completely the exchanger by an hot air jet
for greater safety fill the exchanger with glycoled solution
5. protect the exchanger from the air
6. Remove the drain plugs to the pumps

Before starting a washing the plant.



It's recommended that the starting-up after the stopping period is performed by a qualified technician, especially after seasonal stops or seasonal switch.

When restarting, refer to what is indicated in the START-UP section.

Schedule technical assistance in advance to avoid hitches and to guarantee that the system can be used when required.

8.11 COMPRESSOR SUPPLY LINE SHUT-OFF VALVE

Only if shut-off valve is present .

Do not remove the seal.

Remove only by qualified technician.

Contact the manufacturer for informations

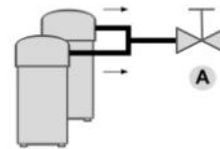

A shut-off valve

9 - DECOMMISSIONING

9.1 DISCONNECTING

Only authorised personnel must disconnect the unit.

- Avoid leak or spills into the environment .
- Before disconnecting the unit, the following must be recovered, if present:
 - refrigerant gas
 - Anti-freeze solutions in the hydraulic circuit
- Awaiting dismantling and disposal, the unit can also be stored outdoors, as bad weather and rapid changes in temperature will not cause damage to the environment, if electric, cooling and hydraulic circuits of the unit are integral and closed.

9.2 DISMANTLING AND DISPOSAL

THE UNIT MUST ALWAYS BE SENT TO AUTHORISED CENTRES FOR DISMANTLING AND DISPOSAL.

When dismantling the unit, the fan, the motor and the coil, if operating, may be recovered by the specialist centres for reuse.

All the materials must be recovered or disposed of in compliance with the corresponding national standards in force.

For further information on the decommissioning of the unit, contact the manufacturer.

9.3 CE RAEE CE DIRECTIVE

- The units covered by the legislation in question are marked with the symbol on the side.
- With the aim of protecting the environment, all of our units are produced in compliance with Directive EC on waste electrical and electronic equipment (WEEE).
- The potential effects on the environment and on human health due to the presence of hazardous substances are shown in the use and maintenance manual in the section on residual risks.
- Information in addition to that indicated below, if required, can be obtained from the manufacturer/distributor/importer, who are responsible for the collection/handling of waste originating from equipment covered by EC - WEEE. This information is also available from the retailer who sold this appliance or from the local authorities who handle waste.
-
- Directive EC - WEEE requires disposal and recycling of electrical and electronic equipment as described therein to be handled through appropriate collection, in suitable centres, separate from collection for the disposal of mixed urban waste.
- The user must not dispose of the unit at the end of its life

cycle as urban waste. It must instead be handed over to appropriate collection centres as set forth by current standards or as instructed by the distributor.

- If disposal takes place at the same time as delivery of a new electrical or electronic equipment for the same family, the product may be collected directly by the distributor.



10 - RESIDUAL RISKS

General

In this section the most common situations are signalled. As these cannot be controlled by the manufacturer these could be a source of risk situations for people or things

Danger zone

This is an area in which only an authorised operator may work.

The danger zone is the area inside the unit which is accessible only with the deliberate removal of protections or parts thereof

Handling

The handling operations, if implemented without all of the protection necessary and without due caution, may cause the fall or the tipping of the unit with the consequent damage, even serious, to persons, things or the unit itself.

Handle the unit following the instructions provided in the present manual regarding the packaging and in compliance with the local regulations in force.

Should the gas refrigerant leak please refer to the refrigerant "Safety sheet".

Installation

An incorrect installation of the unit could cause water leaks, condensate accumulation, leaking of the refrigerant, electric shock, bad functioning or damage to the unit itself.

Check that the installation has been implemented by qualified technical personnel only and that the instructions contained in the present manual and the local regulations in force have been adhered to.

The installation of the unit in a place where even infrequent leaks of inflammable gas and the accumulation of this gas in the area surrounding the area occur could cause explosions or fires.

Carefully check the positioning of the unit.

The installation of the unit in a place unsuited to support its weight and/or guarantee adequate anchorage may cause the fall or the tipping of the unit with the consequent damage to things, people or the unit itself.

Carefully check the positioning and the anchoring of the unit.

Easy access to the unit by children, unauthorised persons or animals may be the source of accidents, some serious.

Install the unit in areas which are only accessible to authorised person and/or provide protection against intrusion into the danger zone .

General risks

Smell of burning, smoke or other signals of serious anomalies may indicate a situation which could cause damage to people, things or the unit itself.

Electrically isolate the unit (yellow-red isolator).

Contact the authorised service centre to identify and resolve the problem at the source of the anomaly.

Accidental contact with exchange batteries, compressors, air delivery tubes or other components may cause injuries and/or burns.

Always wear suitable clothing including protective gloves to work inside the danger zone.

Maintenance and repair operations carried out by non-qualified personnel may cause damage to persons, things or the unit itself.

Always contact the qualified assistance centre.

Failing to close the unit panels or failure to check the correct tightening of all of the panelling fixing screws may cause damage to persons, things or the unit itself.

Periodically check that all of the panels are correctly closed and fixed.

If there is a fire the temperature of the refrigerant could reach values that increase the pressure to beyond the safety valve with the consequent possible projection of the refrigerant itself or explosion of the circuit parts that remain isolated by the closure of the tap.

Do not remain in the vicinity of the safety valve and never leave the refrigerating system taps closed.

Electric parts

An incomplete attachment line to the electric network or with incorrectly sized cables and/or unsuitable protective devices can cause electric shocks, intoxication, damage to the unit or fires.

Carry out all of the work on the electric system referring to the electric layout and the present manual ensuring the use of a system thereto dedicated.

An incorrect fixing of the electric components cover may favour the entry of dust, water etc inside and may consequently can electric shocks, damage to the unit or fires.

Always fix the unit cover properly.

When the metallic mass of the unit is under voltage and is not correctly connected to the earthing system it may be as source of electric shock and electrocution.

Always pay particular attention to the implementation of the earthing system connections.

Contact with parts under voltage accessible inside the unit after the removal of the guards can cause electric shocks, burns and electrocution.

Open and padlock the general isolator prior to removing the guards and signal work in progress with the appropriate shield.

Contact with parts that could be under voltage due to the start up of the unit may cause electric shocks, burns and electrocution.

When voltage is necessary for the circuit open the isolator on the attachment line of the unit itself, padlock it and display the appropriate warning shield.

Moving parts

Contact with the transmissions or with the fan aspiration can cause injuries.

Prior to entering the inside of the unit open the isolator situated on the connection line of the unit itself, padlock and display the suitable sign.

Contact with the fans can cause incurie.

Prior to removing the protective grill or the fans, open the isolator on the attachment line of the unit itself, padlock it and display the appropriate warning sign.

Refrigerant

The intervention of the safety valve and the consequent expulsion of the gas refrigerant may cause injuries and intoxication. Always wear suitable clothing including protective gloves and eyeglasses for operations inside the danger zone.

Should the gas refrigerant leak please refer to the refrigerant "Safety sheet".

Contact between open flames or heat sources with the refrigerant or the heating of the gas circuit under pressure (e.g. during welding operations) may cause explosions or fires.

Do not place any heat source inside the danger zone.

The maintenance or repair interventions which include welding must be carried out with the system off.

Hydraulic parts

Defects in tubing, the attachments or the cut-off parts may cause a leak or water projection with the consequent damages to people, things or shortcircuit the unit.

Excellence version (SC)

General technical data (SC)

Acoustic configuration: compressor soundproofing (SC)

Size			352	402	432	452	502	552	602	702	802
Cooling											
Cooling capacity	1	kW	96,0	109	121	129	141	152	175	196	217
Compressor power input	1	kW	27,4	31,6	35,4	36,2	40,3	44,1	50,9	56,0	63,2
Total power input	2	kW	30,2	34,4	38,3	40,3	44,5	48,3	55,0	61,4	68,6
Total recovery heating capacity	3	kW	119	139	151	161	176	190	215	242	269
Partial recovery heating capacity	3	kW	31,2	35,3	39,0	41,7	45,8	49,7	56,1	63,2	70,2
EER	1		3,17	3,18	3,15	3,21	3,17	3,16	3,18	3,18	3,17
Cooling capacity (EN14511:2013)	4	kW	95,6	109	120	129	140	152	174	195	216
Total power input (EN14511:2013)	4	kW	30,7	34,8	38,8	40,9	45,0	49,0	55,8	62,3	69,6
EER (EN 14511:2013)	4		3,12	3,13	3,10	3,15	3,12	3,10	3,12	3,13	3,11
ESEER	4		4,22	4,30	4,22	4,21	4,24	4,26	4,16	4,32	4,10
Compressor											
Type of compressors			SCROLL	SCROLL	SCROLL	SCROLL	SCROLL	SCROLL	SCROLL	SCROLL	SCROLL
No. of compressors		No	2	2	2	2	2	2	2	2	2
Rated power (C1)		HP	35	40	43	45	50	55	60	70	80
Std Capacity control steps		No	3	3	3	3	3	3	2	3	2
Oil charge (C1)		l	8,00	10,0	12,0	10,0	11,0	13,0	13,0	13,0	13,0
Refrigerant charge (C1)	5	kg	28	28	32	39	39	39	45	51	58
Refrigeration circuits		No	1	1	1	1	1	1	1	1	1
Internal exchanger											
Type of internal exchanger	6		PHE	PHE	PHE	PHE	PHE	PHE	PHE	PHE	PHE
Water flow rate (Utility Side)	1	l/s	4,60	5,20	5,80	6,20	6,70	7,30	8,40	9,30	10,4
Internal exchanger pressure drops	1	kPa	30,0	29,9	30,2	35,0	34,3	39,8	40,3	41,3	41,3
Water content		l	6,90	8,00	8,90	8,90	10,1	10,1	11,9	14,2	17,2
External Section Fans											
Type of fans	7		AX	AX	AX	AX	AX	AX	AX	AX	AX
Number of fans		No	2	2	2	3	3	3	3	4	4
Standard air flow		l/s	12327	12248	12182	18373	18373	18216	18102	24227	24069
Connections											
Water connections			2" 1/2	2" 1/2	2" 1/2	2" 1/2	2" 1/2	2" 1/2	2" 1/2	2" 1/2	2" 1/2
Power supply											
Standard power supply		V	400/3/50	400/3/50	400/3/50	400/3/50	400/3/50	400/3/50	400/3/50	400/3/50	400/3/50
Dimensions											
A - Length		mm	3075	3075	3075	4025	4025	4025	4025	5025	5025
B - Width		mm	1097	1097	1097	1097	1097	1097	1097	1097	1097
C - Height		mm	1805	1805	1805	1805	1805	1805	1805	1805	1805
Standard unit weights											
Shipping weight		kg	889	925	1015	1198	1224	1246	1290	1483	1527
Operating weight		kg	896	933	1024	1207	1234	1256	1302	1497	1544

1. Data referred to the following conditions: Internal exchanger water temperature = 12/7 °C. External exchanger inlet air temperature = 35 °C
2. The Total Power Input value does not take into account the part related to the pumps and required to overcome the pressure drops for the circulation of the solution inside the exchangers
3. Option. Recovery exchanger water = 40/45 °C

4. Data calculated in compliance with Standard EN 14511:2013 referred to the following conditions: Internal exchanger water temperature = 12/7 °C. External exchanger intake air temperature = 35 °C
5. Indicative values for standard units with possible +/-10% variation. The actual data are indicated on the label of the unit.
6. PHE = plates
7. AX = axial fan

Operating range - Cooling (SC)

Acoustic configuration: compressor soundproofing (SC)

Size			352	402	432	452	502	552	602	702	802
External exchanger											
Max inlet air temperature	1	°C	47	46	46	47	47	46	46	47	46
Max inlet air temperature	2	°C	50	50	50	50	50	50	50	50	50
Min. inlet air temperature	3	°C	-10	-10	-10	-10	-10	-10	-10	-10	-10
Min. inlet air temperature	4	°C	-7,0	-7,0	-7,0	-7,0	-7,0	-7,0	-7,0	-7,0	-7,0
Min. inlet air temperature	5	°C	-2,0	-2,0	-2,0	-2,0	-2,0	-2,0	-2,0	-2,0	-2,0
Min. inlet air temperature	6	°C	11	11	11	11	11	11	11	11	11
Internal exchanger											
Max inlet water temperature		°C	24	24	24	24	24	24	24	24	24
Min. outlet water temperature	7	°C	5,0	5,0	5,0	5,0	5,0	5,0	5,0	5,0	5,0
Min. outlet water temperature	8	°C	-7,0	-7,0	-7,0	-7,0	-7,0	-7,0	-7,0	-7,0	-7,0

Data referred to the following conditions:
 - internal exchanger water = 12/7°C
 - air at rest

Caution: Air conditions which are at rest are defined as the absence of air flowing towards the unit. Weak winds can induce air to flow through the exchanger and air-levels which can cause a reduction in the operating range. In the presence of predominant winds it is necessary to use suitable windbreak barriers.

N.B. To ensure the correct maintenance (no operation) with outdoor air temperatures less than -10°C, the Standard unit (no FREE-COOLING configuration) must be equipped with the "Electrical panel anti-freeze protection" option and continue to be supplied with power. The hydraulic circuit must be filled with an adequate percentage of anti-

freeze. In these conditions, the minimum outdoor air temperature which is permitted depends on the model of the "Electrical panel anti-freeze protection" option which has been chosen, up to a limit value of -39°C. The operating mode can also be extended up to an outdoor air temperature of -25°C, but only in the FREE-COOLING configuration which is complete with an "Electrical panel anti-freeze protection" option of an adequate size. The operating mode can be further extended to external air temperatures of 39°C. Only in the full FREE-COOLING configuration of the 'Device to reduce consumption of external section fans operating at variable speed (phase cut)' and 'Electrical panel antifreeze protection' of an adequate size. In the Standard unit (no FREE-COOLING configuration) with an empty hydraulic circuit and without a power supply, correct maintenance (not operating) is possible up to a outdoor air temperature of -20°C.

1. Max. inlet air temperature - Unit at full load
2. Max. inlet air temperature - Unit at part load
3. Min. inlet air temperature - Unit at full load and outdoor air at rest
4. Min. inlet air temperature - Unit at part load and outdoor air at rest

5. Minimum input air temperature - Stepped unit and air speed at 0.5 m/s
6. Minimum input air temperature - Stepped unit and air speed at 1 m/s
7. Standard unit without Low liquid temperature device and air entering the external exchanger at 35°C
8. Unit with Low liquid temperature device and air entering the external exchanger at 35°C. Fluid treated with 40% ethylene glycol.

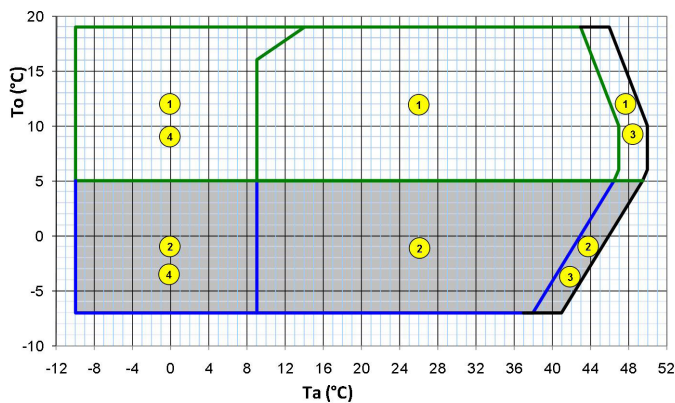

Graph referred to size 352
 The detail of each size is shown in tabular data.

Ta (°C) = external exchanger inlet air temperature (dry bulb).
 To (°C) = internal exchanger outlet water temperature

1. Standard unit: (no "Liquid low temperature" configuration)
2. Unit in "Low liquid temperature" configuration (40% ethylene glycol).
3. capacity-controlled unit (automatic capacity control)
4. Unit at full load: (automatic modulation of the air flow rate)

Sound levels (SC)

Acoustic configuration: compressor soundproofing (SC)

Size	Sound power level (dB)								Sound power level	Sound pressure level
	Octave band (Hz)									
	63	125	250	500	1000	2000	4000	8000	dB(A)	dB(A)
352	90	88	87	84	78	74	66	59	85	67
402	90	87	86	84	79	75	67	59	85	67
432	90	88	87	85	80	77	68	59	86	68
452	91	89	87	85	81	75	68	60	86	68
502	91	89	88	86	81	76	68	60	87	68
552	92	89	89	86	82	77	69	61	88	69
602	91	89	88	86	83	77	69	60	88	69
702	93	91	90	88	84	78	70	62	89	70
802	93	91	90	88	84	78	70	62	89	70

Sound levels refer to full load units, in test nominal conditions. The sound pressure level refers to 1 m. from the unit outer surface operating in open field. Measures according to UNI EN ISO 9614-2 regulations, with respect to the EUROVENT 8/1 certification.

Data referred to the following conditions:
 internal exchanger water = 12/7°C
 outdoor air temperature 35°C

Internal exchanger pressure drops

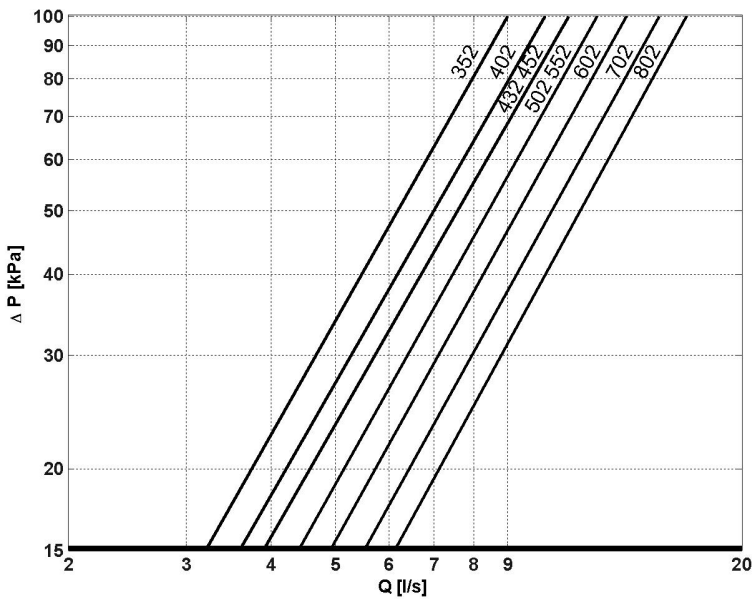

The pressure drops on the water side are calculated by considering an average water temperature at 7°C

Q = Water flow rate (l/s)
 DP = Pressure drop [kPa]

The water flow rate must be calculated with the following formula

$$Q \text{ [l/s]} = \text{kWf} / (4,186 \times \text{DT})$$

kWf = Cooling capacity in kW
 DT = Temperature difference between inlet / outlet water



To the internal exchanger pressure drops must be added the pressure drops of the mechanical steel mesh strainer that must be placed on the water input line. It is a device compulsory for the correct unit operation, and it is available as Clivet option. (See the HYDRONIC ASSEMBLY ACCESSORIES). If the mechanical strainer is selected and installed by the Customer, it is forbidden the use of filters with the mesh pitch higher than 1,6 mm, because they can cause a bad unit operation and also its serious damaging.

Admissible water flow rates

Min. (Qmin) and max. (Qmax) water flow-rates admissibles for the correct unit operation.

Size		352	402	432	452	502	552	602	702	802
Qmin	[l/s]	3,2	3,6	3,9	3,9	4,4	4,4	4,9	5,5	6,1
Qmax	[l/s]	9,0	10,2	11,1	11,1	12,2	12,2	13,5	15,1	16,6

Excellence version (EN)

General technical data (EN)

Acoustic Treatment: extremely low noise (EN)

Size			352	402	432	452	502	552	602	702	802
Cooling											
Cooling capacity	1	kW	91,5	104	116	125	134	145	165	185	207
Compressor power input	1	kW	28,5	32,9	37,1	37,7	42,1	46,1	53,4	58,5	66,2
Total power input	2	kW	30,1	34,5	38,7	39,9	44,3	48,3	55,6	61,4	69,1
Total recovery heating capacity	3	kW	119	139	151	161	176	190	215	242	269
Partial recovery heating capacity	3	kW	30,0	34,2	38,2	40,6	44,2	48,0	55,1	60,8	68,8
EER	1		3,04	3,01	2,99	3,13	3,03	3,01	2,96	3,01	3,00
Cooling capacity (EN14511:2013)	4	kW	91,0	103	115	124	134	145	164	184	206
Total power input (EN14511:2013)	4	kW	30,6	35,2	39,3	40,6	44,9	48,9	56,4	62,0	69,9
EER (EN 14511:2013)	4		2,97	2,94	2,93	3,06	2,98	2,96	2,91	2,97	2,95
ESEER	4		4,08	4,22	4,15	4,14	4,12	4,10	4,09	4,15	3,98
Compressor											
Type of compressors			SCROLL	SCROLL	SCROLL	SCROLL	SCROLL	SCROLL	SCROLL	SCROLL	SCROLL
No. of compressors		No	2	2	2	2	2	2	2	2	2
Rated power (C1)		HP	35	40	43	45	50	55	60	70	80
Std Capacity control steps		No	3	3	3	3	3	3	2	3	2
Oil charge (C1)		l	8,00	10,0	12,0	10,0	11,0	13,0	13,0	13,0	13,0
Refrigerant charge (C1)	5	kg	28,3	28,3	31,9	39,5	39,5	39,5	44,6	51,3	57,9
Refrigeration circuits		No	1	1	1	1	1	1	1	1	1
Internal exchanger											
Type of internal exchanger	6		PHE	PHE	PHE	PHE	PHE	PHE	PHE	PHE	PHE
Water flow rate (Utility Side)	1	l/s	4,40	5,00	5,50	6,00	6,40	6,90	7,90	8,80	9,90
Internal exchanger pressure drops	1	kPa	26,8	26,9	28,0	32,1	30,8	35,1	37,3	36,3	38,1
Water content		l	6.90	8.00	8.90	8.90	10.1	10.1	11.9	14.2	17.2
External Section Fans											
Type of fans	7		AX	AX	AX	AX	AX	AX	AX	AX	AX
Number of fans		No	2	2	2	3	3	3	3	4	4
Standard air flow		l/s	9636	9571	9517	14358	14358	14253	14138	18925	18798
Connections											
Water connections			2" 1/2	2" 1/2	2" 1/2	2" 1/2	2" 1/2	2" 1/2	2" 1/2	2" 1/2	2" 1/2
Power supply											
Standard power supply		V	400/3/50	400/3/50	400/3/50	400/3/50	400/3/50	400/3/50	400/3/50	400/3/50	400/3/50
Dimensions											
A - Length		mm	3075	3075	3075	4025	4025	4025	4025	5025	5025
B - Width		mm	1097	1097	1097	1097	1097	1097	1097	1097	1097
C - Height		mm	1805	1805	1805	1805	1805	1805	1805	1805	1805
Standard unit weights											
Shipping weight		kg	889	925	1015	1198	1224	1246	1290	1483	1527
Operating weight		kg	896	933	1024	1207	1234	1256	1302	1497	1544

1. Data referred to the following conditions: internal exchanger water = 12/7 °C external exchanger inlet air 35°C
2. The Total Power Input value does not take into account the part related to the pumps and required to overcome the pressure drops for the circulation of the solution inside the exchangers
3. Option. Recovery exchanger water = 40/45°C

4. Data calculated in compliance with Standard EN 14511:2013 referred to the following conditions: Internal exchanger water temperature = 12/7°C. External exchanger intake air temperature = 35°C
5. indicative values for standard units with possible +/-10% variation. The actual data are indicated on the label of the unit.
6. PHE = plates
7. AX = axial fan

Operating range - Cooling (EN)

Acoustic Treatment: extremely low noise (EN)

Size			352	402	432	452	502	552	602	702	802
External exchanger											
Max inlet air temperature	1	°C	46	45	44	46	46	45	44	46	45
Max inlet air temperature	2	°C	47	46	46	47	47	46	46	47	46
Max inlet air temperature	3	°C	50	50	50	50	50	50	50	50	50
Min. inlet air temperature	4	°C	-10	-10	-10	-10	-10	-10	-10	-10	-10
Min. inlet air temperature	5	°C	-7,0	-7,0	-7,0	-7,0	-7,0	-7,0	-7,0	-7,0	-7,0
Min. inlet air temperature	6	°C	-2,0	-2,0	-2,0	-2,0	-2,0	-2,0	-2,0	-2,0	-2,0
Min. inlet air temperature	7	°C	11	11	11	11	11	11	11	11	11
Internal exchanger											
Max inlet water temperature		°C	24	24	24	24	24	24	24	24	24
Min. outlet water temperature	8	°C	5,0	5,0	5,0	5,0	5,0	5,0	5,0	5,0	5,0
Min. outlet water temperature	9	°C	-7,0	-7,0	-7,0	-7,0	-7,0	-7,0	-7,0	-7,0	-7,0

Data referred to the following conditions:
 internal exchanger water = 12/7°C
 air at rest

Caution: Air conditions which are at rest are defined as the absence of air flowing towards the unit. Weak winds can induce air to flow through the exchanger and air-levels which can cause a reduction in the operating range. In the presence of predominant winds it is necessary to use suitable windbreak barriers.
 N.B. To ensure the correct maintenance (no operation) with outdoor air temperatures less than -10°C, the Standard unit (no FREE-COOLING configuration) must be equipped with the "Electrical panel anti-freeze protection" option and continue to be supplied with power. The hydraulic circuit must be filled with an adequate percentage of anti-freeze. In these conditions, the minimum outdoor air temperature which is permitted depends on the model of the "Electrical panel anti-freeze protection" option which has been chosen, up to a limit value of -39°C.

The operating mode can also be extended up to an outdoor air temperature of -25°C, but only in the FREE-COOLING configuration which is complete with an "Electrical panel anti-freeze protection" option of an adequate size. The operating mode can be further extended to external air temperatures of 39°C. Only in the full FREE-COOLING configuration of the 'Device to reduce consumption of external section fans operating at variable speed (phase cut)' and 'Electrical panel antifreeze protection' of an adequate size.
 In the Standard unit (no FREE-COOLING configuration) with an empty hydraulic circuit and without a power supply, correct maintenance (not operating) is possible up to an outdoor air temperature of -20°C.

1. Max. inlet air temperature - Unit at full load
2. Input air maximum temperature - Unit operating at full load with fans automatically forced at maximum speed (the sound levels in this particular operating condition are the same as the standard acoustic configuration SC)
3. Max. inlet air temperature - Unit at part load
4. Min. inlet air temperature - Unit at full load and outdoor air at rest

5. Min. inlet air temperature - Unit at part load and outdoor air at rest
6. Minimum input air temperature - Stepped unit and air speed at 0.5 m/s.
7. Minimum input air temperature - Stepped unit and air speed at 1 m/s
8. Standard unit without Low liquid temperature device and air entering the external exchanger at 35°C
9. Unit with Low liquid temperature device and air entering the external exchanger at 35°C. Fluid treated with 40% ethylene glycol.

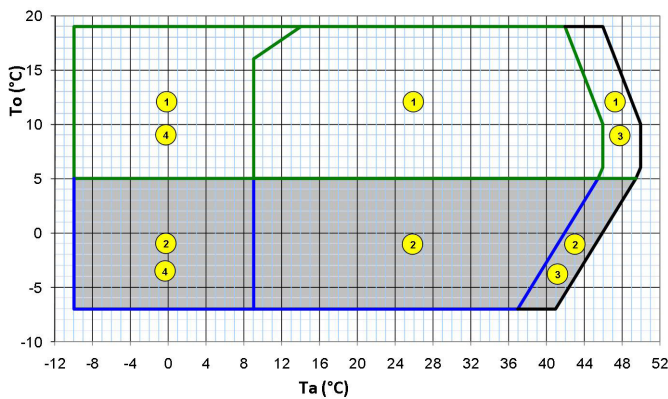

Graph referred to size 352
 The detail of each size is shown in tabular date.

Ta (°C) = external exchanger inlet air temperature (dry bulb).
 To (°C) = internal exchanger outlet water temperature

1. Standard unit: (no "Liquid low temperature" configuration)
2. Unit in "Low liquid temperature" configuration (40% ethylene glycol).
3. capacity-controlled unit (automatic capacity control)
4. Unit at full load: (automatic modulation of the air flow rate)

Sound levels (EN)

Acoustic Treatment: extremely low noise (EN)

Size	Sound power level (dB)								Sound power level	Sound pressure level
	Octave band (Hz)									
	63	125	250	500	1000	2000	4000	8000	dB(A)	dB(A)
352	82	84	84	80	71	68	60	55	81	63
402	82	83	84	80	74	70	62	57	81	63
432	82	83	86	82	75	71	62	57	83	65
452	85	85	86	83	76	70	63	58	83	65
502	84	85	87	83	76	71	63	57	84	66
552	84	85	87	83	78	72	64	59	84	66
602	84	85	87	84	78	72	64	58	85	66
702	86	86	88	85	79	73	65	59	86	67
802	86	86	89	85	80	73	66	60	86	67

Sound levels refer to full load units, in test nominal conditions. The sound pressure level refers to 1 m. from the unit outer surface operating in open field. Measures according to UNI EN ISO 9614-2 regulations, with respect to the EUROVENT 8/1 certification.

Data referred to the following conditions:
 internal exchanger water = 12/7°C
 outdoor air temperature 35°C

The indicated sound levels are only valid within the operating field of the unit in the "Supersilenced EN" configuration; with fresh air temperatures which are higher and in any case within the operating field of the "Soundproofed Compressors SC" configuration bearing in mind the sound levels of the unit in the "Soundproofed Compressors SC" configuration.

Internal exchanger pressure drops

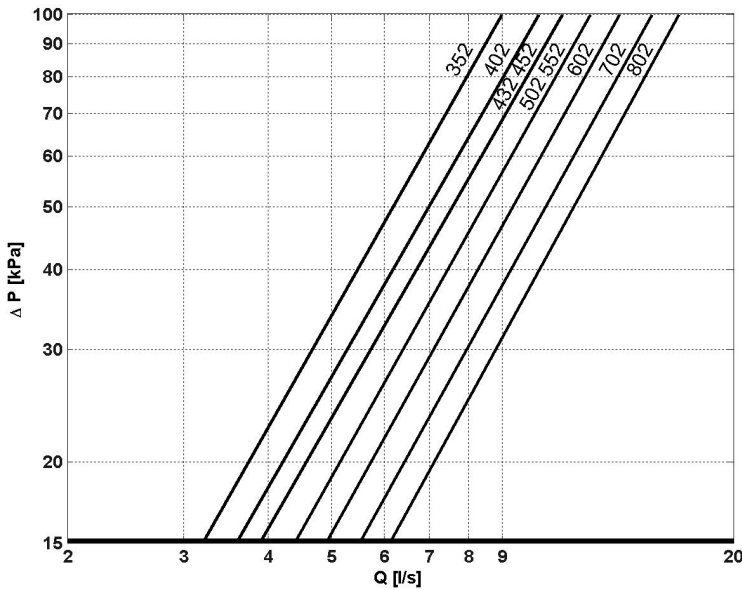

The pressure drops on the water side are calculated by considering an average water temperature at 7°C

Q = water flow rate (l/s)
 DP = pressure drop [kPa]

The water flow rate must be calculated with the following formula

$$Q \text{ [l/s]} = \frac{kWf}{4,186 \times DT}$$

kWf = Cooling capacity in kW
 DT = Temperature difference between inlet / outlet water



To the internal exchanger pressure drops must be added the pressure drops of the mechanical steel mesh strainer that must be placed on the water input line. It is a device compulsory for the correct unit operation, and it is available as Clivet option. (See the HYDRONIC ASSEMBLY ACCESSORIES). If the mechanical strainer is selected and installed by the Customer, it is forbidden the use of filters with the mesh pitch higher than 1,6 mm, because they can cause a bad unit operation and also its serious damaging.

Admissible water flow rates

Min. (Qmin) and max. (Qmax) water flow-rates admissibles for the correct unit operation.

Size		352	402	432	452	502	552	602	702	802
Qmin	[l/s]	3,2	3,6	3,9	3,9	4,4	4,4	4,9	5,5	6,1
Qmax	[l/s]	9,0	10,2	11,1	11,1	12,2	12,2	13,5	15,1	16,6

Premium version (SC)

General technical data (SC)

Acoustic configuration: compressor soundproofing (SC)

Size			352	402	432	452	502	552	602	702	802
Cooling											
Cooling capacity	1	kW	90,3	101	111	120	131	144	160	185	204
Compressor power input	1	kW	28,8	33,8	38,0	40,3	43,9	49,1	56,8	61,1	70,3
Total power input	2	kW	32,1	37,1	41,3	43,7	47,4	52,6	60,1	66,0	75,1
Total recovery heating capacity	3	kW	114	129	144	155	169	186	208	238	263
Partial recovery heating capacity	3	kW	30,0	33,9	37,7	40,5	43,6	47,9	54,5	60,9	68,4
EER	1		2,81	2,73	2,69	2,75	2,75	2,73	2,66	2,81	2,71
Cooling capacity (EN14511:2013)	4	kW	89,8	101	111	119	130	143	159	185	203
Total power input (EN14511:2013)	4	kW	32,6	37,7	42,0	44,2	48,0	53,2	61,0	66,9	75,9
EER (EN 14511:2013)	4		2,75	2,67	2,64	2,70	2,71	2,69	2,61	2,76	2,67
ESEER	4		3,91	3,95	3,90	4,03	4,02	3,99	3,90	3,99	3,79
Compressor											
Type of compressors			SCROLL	SCROLL	SCROLL	SCROLL	SCROLL	SCROLL	SCROLL	SCROLL	SCROLL
No. of compressors		No	2	2	2	2	2	2	2	2	2
Rated power (C1)		HP	35	40	43	45	50	55	60	70	80
Std Capacity control steps		No	3	3	3	3	3	3	2	3	2
Oil charge (C1)		l	8,00	10,0	12,0	10,0	11,0	13,0	13,0	13,0	13,0
Refrigerant charge (C1)	5	kg	18	18	22	24	27	27	32	39	39
Refrigeration circuits		No	1	1	1	1	1	1	1	1	1
Internal exchanger											
Type of internal exchanger	6		PHE	PHE	PHE	PHE	PHE	PHE	PHE	PHE	PHE
Water flow rate (Utility Side)	1	l/s	4,30	4,80	5,30	5,70	6,20	6,90	7,60	8,90	9,70
Internal exchanger pressure drops	1	kPa	47,2	47,1	47,6	45,2	41,1	41,1	43,1	44,7	44,1
Water content		l	4,80	5,50	6,10	6,90	8,00	8,90	10,1	11,9	14,2
External Section Fans											
Type of fans	7		AX	AX	AX	AX	AX	AX	AX	AX	AX
Number of fans		No	2	2	2	2	2	2	2	3	3
Standard air flow		l/s	12474	12474	12394	12119	11871	11871	12268	18536	18536
Connections											
Water connections			2" 1/2	2" 1/2	2" 1/2	2" 1/2	2" 1/2	2" 1/2	2" 1/2	2" 1/2	2" 1/2
Power supply											
Standard power supply		V	400/3/50	400/3/50	400/3/50	400/3/50	400/3/50	400/3/50	400/3/50	400/3/50	400/3/50
Dimensions											
A - Length		mm	2710	2710	2710	2710	2710	2710	3075	4025	4025
B - Width		mm	1097	1097	1097	1097	1097	1097	1097	1097	1097
C - Height		mm	1805	1805	1805	1805	1805	1805	1805	1805	1805
Standard unit weights											
Shipping weight		kg	773	796	885	917	955	975	1077	1283	1310
Operating weight		kg	778	802	892	924	963	984	1087	1295	1324

1. Data referred to the following conditions: internal exchanger water = 12/7 °C external exchanger inlet air 35°C
2. data referred to the following conditions: internal exchanger water = 12/7 °C. external exchanger inlet water 35°C
3. The Total Power Input value does not take into account the part related to the pumps and required to overcome the pressure drops for the circulation of the solution inside the exchangers
4. Option. Recovery exchanger water = 40/45°C

5. Data calculated in compliance with Standard EN 14511:2013 referred to the following conditions: Internal exchanger water temperature = 12/7°C. External exchanger intake air temperature = 35°C
6. indicative values for standard units with possible +/-10% variation. The actual data are indicated on the label of the unit.
7. PHE = plates
8. AX = axial fan

Operating range - Cooling (SC)

Acoustic configuration: compressor soundproofing (SC)

Size			352	402	432	452	502	552	602	702	802
External exchanger											
Max inlet air temperature	1	°C	45	44	43	44	44	43	42	44	43
Max inlet air temperature	2	°C	50	50	50	50	50	50	50	50	50
Min. inlet air temperature	3	°C	-10	-10	-10	-10	-10	-10	-10	-10	-10
Min. inlet air temperature	4	°C	-7,0	-7,0	-7,0	-7,0	-7,0	-7,0	-7,0	-7,0	-7,0
Min. inlet air temperature	5	°C	-2,0	-2,0	-2,0	-2,0	-2,0	-2,0	-2,0	-2,0	-2,0
Min. inlet air temperature	6	°C	11	11	11	11	11	11	11	11	11
Internal exchanger											
Max inlet water temperature		°C	24	24	24	24	24	24	24	24	24
Min. outlet water temperature	7	°C	5.0	5.0	5.0	5.0	5.0	5.0	5.0	5.0	5.0
Min. outlet water temperature	8	°C	-7.0	-7.0	-7.0	-7.0	-7.0	-7.0	-7.0	-7.0	-7.0

Data referred to the following conditions:
 internal exchanger water = 12/7°C
 air at rest

Caution: Air conditions which are at rest are defined as the absence of air flowing towards the unit. Weak winds can induce air to flow through the exchanger and air-levels which can cause a reduction in the operating range. In the presence of predominant winds it is necessary to use suitable windbreak barriers.

N.B. To ensure the correct maintenance (no operation) with outdoor air temperatures less than -10°C, the Standard unit (no FREE-COOLING configuration) must be equipped with the "Electrical panel anti-freeze protection" option and continue to be supplied with power. The hydraulic circuit must be filled with an adequate percentage of anti-freeze. In these conditions, the minimum outdoor air temperature which is permitted depends on the model of the "Electrical panel anti-freeze protection" option which has been chosen, up to a limit value of -39°C.

The operating mode can also be extended up to an outdoor air temperature of -25°C, but only in the FREE-COOLING configuration which is complete with an "Electrical panel anti-freeze protection" option of an adequate size. The operating mode can also be extended up to an external air temperature of -39°C, but only in the FREE-COOLING configuration which is complete with the "Electrical panel anti-freeze protection" option of an adequate size. In the Standard unit (no FREE-COOLING configuration) with an empty hydraulic circuit and without a power supply, correct maintenance (not operating) is possible up to a outdoor air temperature of -20°C.

1. Max. inlet air temperature - Unit at full load
2. Max. inlet air temperature - Unit at part load
3. Min. inlet air temperature - Unit at full load and outdoor air at rest
4. Min. inlet air temperature - Unit at part load and outdoor air at rest

5. Minimum input air temperature - Stepped unit and air speed at 0.5 m/s.
6. Minimum input air temperature - Stepped unit and air speed at 1 m/s
7. Standard unit without Low liquid temperature device and air entering the external exchanger at 35°C
8. Unit with Low liquid temperature device and air entering the external exchanger at 35°C. Fluid treated with 40% ethylene glycol.

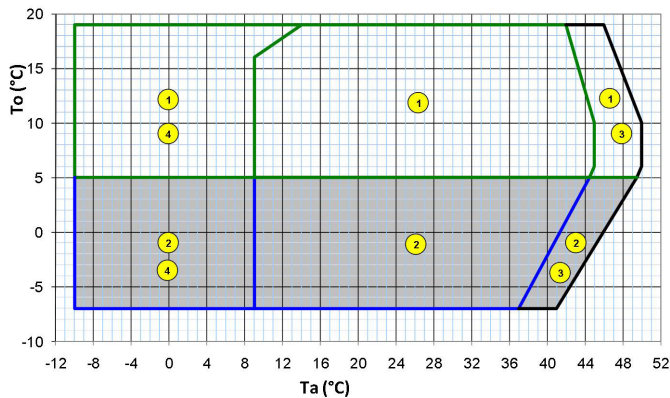

Graph referred to size 352
 The detail of each size is shown in tabular data.

Ta (°C) = external exchanger inlet air temperature (dry bulb).
 To (°C) = internal exchanger outlet water temperature

1. Standard unit: (no "Liquid low temperature" configuration)
2. Unit in "Low liquid temperature" configuration (40% ethylene glycol).
3. capacity-controlled unit (automatic capacity control)
4. Unit at full load: (automatic modulation of the air flow rate)

Sound levels (SC)

Acoustic configuration: compressor soundproofing (SC)

Size	Sound power level (dB)								Sound power level	Sound pressure level
	Octave band (Hz)									
	63	125	250	500	1000	2000	4000	8000	dB(A)	dB(A)
352	90	88	86	84	78	74	66	58	85	67
402	89	87	86	83	79	75	67	59	85	67
432	89	87	86	84	79	75	67	58	85	67
452	89	87	86	84	80	74	67	58	85	67
502	89	86	86	84	80	75	67	57	85	68
552	89	87	86	85	81	76	68	59	86	68
602	89	87	86	85	81	76	68	58	86	68
702	91	89	88	87	83	77	69	60	88	69
802	91	89	88	86	83	77	69	60	88	69

Sound levels refer to full load units, in test nominal conditions. The sound pressure level refers to 1 m. from the unit outer surface operating in open field. Measures according to UNI EN ISO 9614-2 regulations, with respect to the EUROVENT 8/1 certification.

Data referred to the following conditions:
 internal exchanger water = 12/7°C
 outdoor air temperature 35°C

Internal exchanger pressure drops

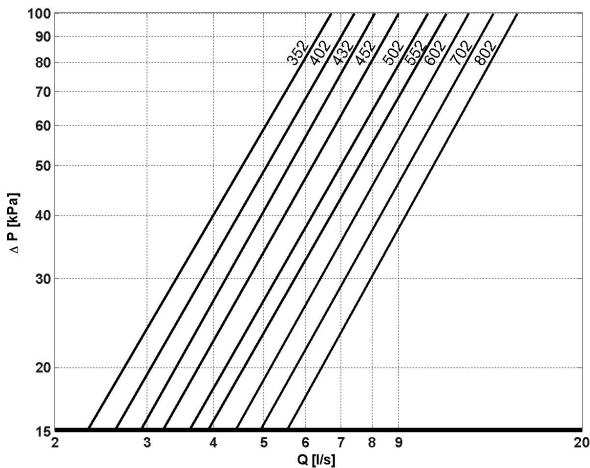

The pressure drops on the water side are calculated by considering an average water temperature at 7°

Q = water flow rate (l/s)
 DP = pressure drop [kPa]

The water flow rate must be calculated with the following formula

$$Q [l/s] = kWf / (4,186 \times DT)$$

kWf = Cooling capacity in kW
 DT = Temperature difference between inlet / outlet water



To the internal exchanger pressure drops must be added the pressure drops of the mechanical steel mesh strainer that must be placed on the water input line. It is a device compulsory for the correct unit operation, and it is available as Clivet option. (See the HYDRONIC ASSEMBLY ACCESSORIES). If the mechanical strainer is selected and installed by the Customer, it is forbidden the use of filters with the mesh pitch higher than 1,6 mm, because they can cause a bad unit operation and also its serious damaging.

Admissible water flow rates

Min. (Qmin) and max. (Qmax) water flow-rates admissible for the correct unit operation.

Size		352	402	432	452	502	552	602	702	802
Qmin	[l/s]	2,3	2,6	2,9	3,2	3,6	3,9	4,4	4,9	5,5
Qmax	[l/s]	6,6	7,4	8,1	9,0	10,2	11,1	12,2	13,5	15,1

Premium version (EN)

General technical data (EN)

Acoustic Treatment: extremely low noise (EN)

Size			352	402	432	452	502	552	602	702	802
Cooling											
Cooling capacity	1	kW	87,0	95,9	105	115	126	136	153	178	193
Compressor power input	1	kW	29,9	35,3	39,9	42,1	45,7	51,6	59,8	64,3	74,4
Total power input	2	kW	32,4	37,8	42,4	44,6	48,2	54,1	62,3	67,8	77,9
Total recovery heating capacity	3	kW	114	129	144	155	169	186	208	238	263
Partial recovery heating capacity	3	kW	28,6	32,7	37,0	39,6	42,8	47,8	54,6	59,2	68,6
EER	1		2,69	2,54	2,48	2,58	2,62	2,51	2,45	2,62	2,48
Cooling capacity (EN14511:2013)	4	kW	86,5	95,3	105	114	125	135	152	177	192
Total power input (EN14511:2013)	4	kW	32,9	38,4	43,1	45,2	48,9	54,8	63,0	68,8	78,8
EER (EN 14511:2013)	4		2,63	2,48	2,43	2,53	2,56	2,47	2,41	2,57	2,44
ESEER	4		3,58	3,75	3,74	3,94	3,92	3,89	3,77	3,80	3,66
Compressor											
Type of compressors			SCROLL	SCROLL	SCROLL	SCROLL	SCROLL	SCROLL	SCROLL	SCROLL	SCROLL
No. of compressors		No	2	2	2	2	2	2	2	2	2
Rated power (C1)		HP	35	40	43	45	50	55	60	70	80
Std Capacity control steps		No	3	3	3	3	3	3	2	3	2
Oil charge (C1)		l	8,00	10,0	12,0	10,0	11,0	13,0	13,0	13,0	13,0
Refrigerant charge (C1)	5	kg	18	18	22	24	27	27	32	39	39
Refrigeration circuits		No	1	1	1	1	1	1	1	1	1
Internal exchanger											
Type of internal exchanger	6		PHE	PHE	PHE	PHE	PHE	PHE	PHE	PHE	PHE
Water flow rate (Utility Side)	1	l/s	4,20	4,60	5,00	5,50	6,00	6,50	7,30	8,50	9,20
Internal exchanger pressure drops	1	kPa	40,7	41,7	43,9	41,2	37,2	38,5	41,2	39,5	42,5
Water content		l	4,80	5,50	6,10	6,90	8,00	8,90	10,1	11,9	14,2
External Section Fans											
Type of fans	7		AX	AX	AX	AX	AX	AX	AX	AX	AX
Number of fans		No	2	2	2	2	2	2	2	3	3
Standard air flow		l/s	10025	10025	10014	9986	9937	9937	10001	15015	15015
Connections											
Water connections			2" 1/2	2" 1/2	2" 1/2	2" 1/2	2" 1/2	2" 1/2	2" 1/2	2" 1/2	2" 1/2
Power supply											
Standard power supply		V	400/3/50	400/3/50	400/3/50	400/3/50	400/3/50	400/3/50	400/3/50	400/3/50	400/3/50
Dimensions											
A - Length		mm	2710	2710	2710	2710	2710	2710	3075	4025	4025
B - Width		mm	1097	1097	1097	1097	1097	1097	1097	1097	1097
C - Height		mm	1805	1805	1805	1805	1805	1805	1805	1805	1805
Standard unit weights											
Shipping weight		kg	773	796	885	917	955	975	1077	1283	1310
Operating weight		kg	778	802	892	924	963	984	1087	1295	1324

1. Data referred to the following conditions: internal exchanger water = 12/7 °C external exchanger inlet air 35°C
2. The Total Power Input value does not take into account the part related to the pumps and required to overcome the pressure drops for the circulation of the solution inside the exchangers
3. Option. Recovery exchanger water = 40/45°C

4. Data calculated in compliance with Standard EN 14511:2013 referred to the following conditions: Internal exchanger water temperature = 12/7°C. External exchanger intake air temperature = 35°C
5. indicative values for standard units with possible +/-10% variation. The actual data are indicated on the label of the unit.
6. PHE = plates
7. AX = axial fan

Operating range - Cooling (EN)

Acoustic Treatment: extremely low noise (EN)

Size			352	402	432	452	502	552	602	702	802
External exchanger											
Max inlet air temperature	1	°C	43	41	40	41	41	40	40	41	40
Max inlet air temperature	2	°C	45	44	43	44	44	43	42	44	43
Max inlet air temperature	3	°C	50	50	50	50	50	50	50	50	50
Min. inlet air temperature	4	°C	-10	-10	-10	-10	-10	-10	-10	-10	-10
Min. inlet air temperature	5	°C	-7,0	-7,0	-7,0	-7,0	-7,0	-7,0	-7,0	-7,0	-7,0
Min. inlet air temperature	6	°C	-2,0	-2,0	-2,0	-2,0	-2,0	-2,0	-2,0	-2,0	-2,0
Min. inlet air temperature	7	°C	11	11	11	11	11	11	11	11	11
Internal exchanger											
Max inlet water temperature		°C	24	24	24	24	24	24	24	24	24
Min. outlet water temperature	8	°C	5.0	5.0	5.0	5.0	5.0	5.0	5.0	5.0	5.0
Min. outlet water temperature	9	°C	-7,0	-7,0	-7,0	-7,0	-7,0	-7,0	-7,0	-7,0	-7,0

Data referred to the following conditions:
 internal exchanger water = 12/7°C
 air at rest

Caution: Air conditions which are at rest are defined as the absence of air flowing towards the unit. Weak winds can induce air to flow through the exchanger and air-levels which can cause a reduction in the operating range. In the presence of predominant winds it is necessary to use suitable windbreak barriers.
 N.B. To ensure the correct maintenance (no operation) with outdoor air temperatures less than -10°C, the Standard unit (no FREE-COOLING configuration) must be equipped with the "Electrical panel anti-freeze protection" option and continue to be supplied with power. The hydraulic circuit must be filled with an adequate percentage of anti-freeze. In these conditions, the minimum outdoor air temperature which is permitted depends on the model of the "Electrical panel anti-freeze protection" option which has been chosen, up to a limit value of -39°C.

The operating mode can also be extended up to an outdoor air temperature of -25°C, but only in the FREE-COOLING configuration which is complete with an "Electrical panel anti-freeze protection" option of an adequate size.
 The operating mode can be further extended to external air temperatures of 39°C. Only in the full FREE-COOLING configuration of the 'Device to reduce consumption of external section fans operating at variable speed (phase cut)' and 'Electrical panel antifreeze protection' of an adequate size.
 In the Standard unit (no FREE-COOLING configuration) with an empty hydraulic circuit and without a power supply, correct maintenance (not operating) is possible up to a outdoor air temperature of -20°C.

1. Max. inlet air temperature - Unit at full load
2. Input air maximum temperature - Unit operating at full load with fans automatically forced at maximum speed (the sound levels in this particular operating condition are the same as the standard acoustic configuration SC)
3. Max. inlet air temperature - Unit at part load
4. Min. inlet air temperature - Unit at full load and outdoor air at rest

5. Min. inlet air temperature - Unit at part load and outdoor air at rest
6. Minimum input air temperature - Stepped unit and air speed at 0.5 m/s.
7. Minimum input air temperature - Stepped unit and air speed at 1 m/s
8. Standard unit without Low liquid temperature device and air entering the external exchanger at 35°C
9. Unit with Low liquid temperature device and air entering the external exchanger at 35°C. Fluid treated with 40% ethylene glycol.

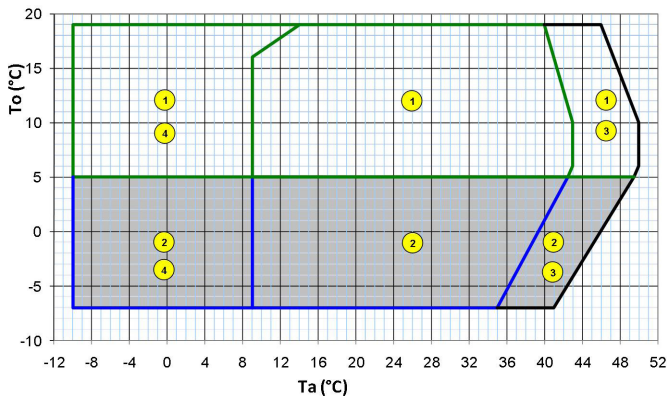

Graph referred to size 352
 The detail of each size is shown in tabular date.

Ta (°C) = external exchanger inlet air temperature (dry bulb).
 To (°C) = internal exchanger outlet water temperature

1. Standard unit:(no "Liquid low temperature" configuration)
2. Unit in "Low liquid temperature" configuration (40% ethylene glycol).
3. capacity-controlled unit (automatic capacity control)
4. Unit at full load: (automatic modulation of the air flow rate)

Sound levels (EN)

Acoustic Treatment: extremely low noise (EN)

Size	Sound power level (dB)								Sound power level	Sound pressure level
	Octave band (Hz)									
	63	125	250	500	1000	2000	4000	8000	dB(A)	dB(A)
352	83	84	85	80	72	69	60	55	81	63
402	82	83	84	80	74	70	62	57	81	63
432	82	83	86	81	75	71	62	56	82	65
452	83	83	85	82	76	70	63	57	83	65
502	81	83	86	82	75	70	62	55	83	65
552	82	83	87	83	77	72	64	58	84	66
602	82	83	86	83	78	71	64	57	84	66
702	85	85	88	85	79	73	65	59	86	67
802	84	85	88	85	79	73	65	59	86	67

Sound levels refer to full load units, in test nominal conditions. The sound pressure level refers to 1 m. from the unit outer surface operating in open field. Measures according to UNI EN ISO 9614-2 regulations, with respect to the EUROVENT 8/1 certification.

Data referred to the following conditions:
 internal exchanger water = 12/7°C
 outdoor air temperature 35°C

The indicated sound levels are only valid within the operating field of the unit in the "Supersilenced EN" configuration; with fresh air temperatures which are higher and in any case within the operating field of the "Soundproofed Compressors SC" configuration bearing in mind the sound levels of the unit in the "Soundproofed Compressors SC" configuration.

Internal exchanger pressure drops

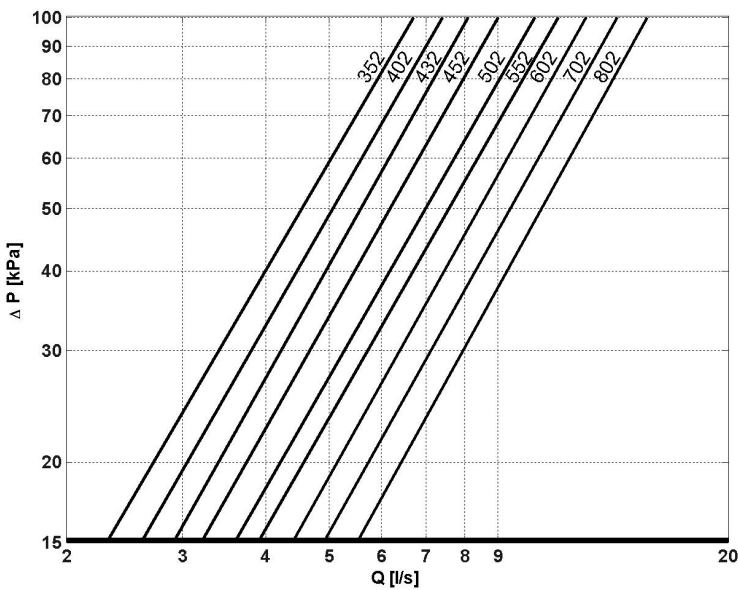

The pressure drops on the water side are calculated by considering an average water temperature at 7°

Q = water flow rate (l/s)
 DP = pressure drop (kPa)

The water flow rate must be calculated with the following formula

$$Q [l/s] = kWf / (4,186 \times DT)$$

kWf = Cooling capacity in kW
 DT = Temperature difference between inlet / outlet water



To the internal exchanger pressure drops must be added the pressure drops of the mechanical steel mesh strainer that must be placed on the water input line. It is a device compulsory for the correct unit operation, and it is available as Clivet option. (See the HYDRONIC ASSEMBLY ACCESSORIES). If the mechanical strainer is selected and installed by the Customer, it is forbidden the use of filters with the mesh pitch higher than 1,6 mm, because they can cause a bad unit operation and also its serious damaging.

Admissible water flow rates

Min. (Qmin) and max. (Qmax) water flow-rates admissibles for the correct unit operation.

Size	352	402	432	452	502	552	602	702	802
Qmin [l/s]	2,3	2,6	2,9	3,2	3,6	3,9	4,4	4,9	5,5
Qmax [l/s]	6,6	7,4	8,1	9,0	10,2	11,1	12,2	13,5	15,1

Dimensional drawings: Excellence version

WSAT-XEE 352-402-432

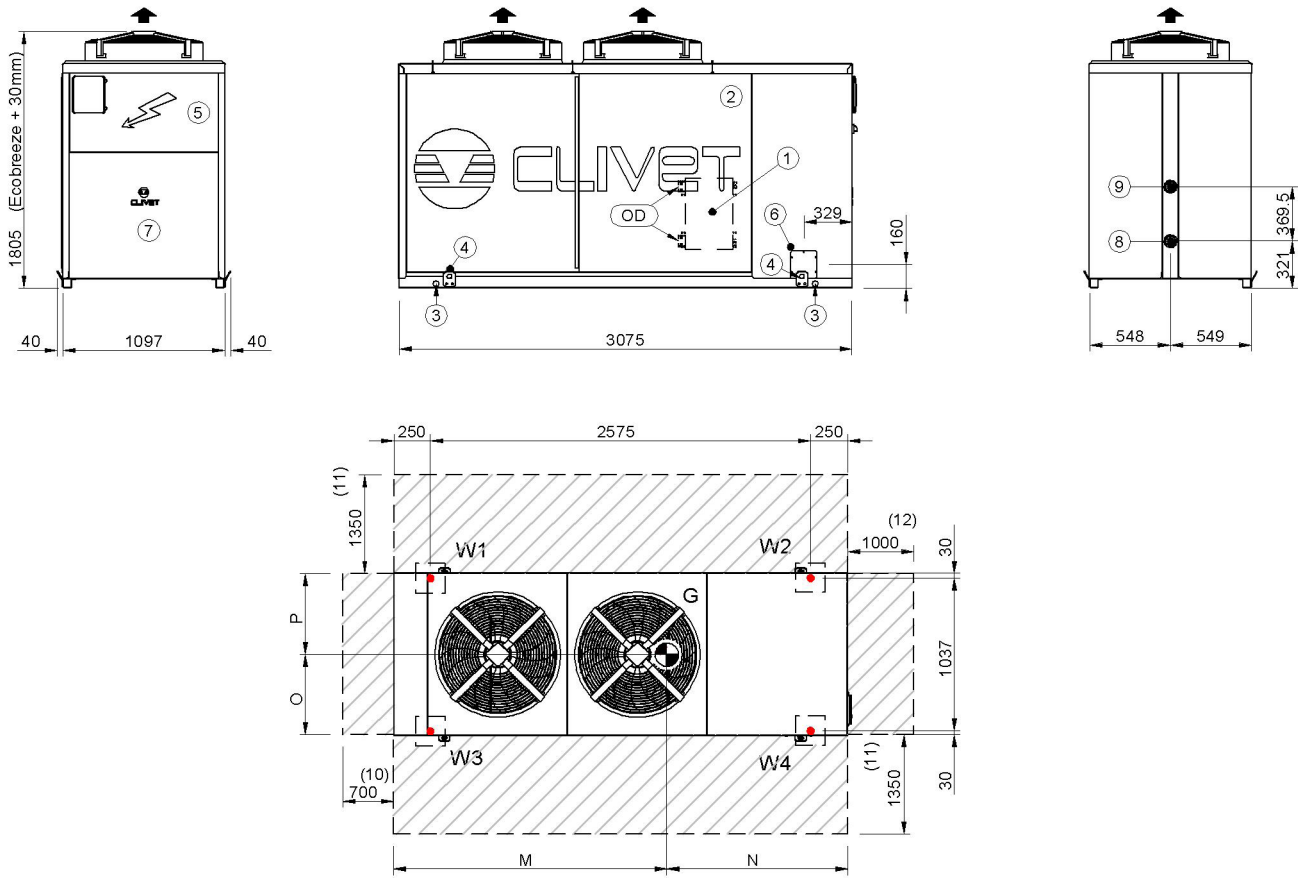

- 1. Internal exchanger (evaporator)
- 2. External exchanger (condenser)
- 3. Unit fixing holes
- 4. Lifting brackets (removable, if required, after the unit positioning)
- 5. Electrical panel
- 6. Power input
- 7. Soundproofed cabin
- 8. Internal exchanger water outlet. The heights of the connections may change if there are optional components: pump, storage tank, free-cooling, partial or total recovery.
- 9. Internal exchanger water inlet. The heights of the connections may change if there are optional components: pump, storage tank, free-cooling, partial or total recovery.
- 10. Minimum Safe Clearance
- 11. Minimum Clearance for a Proper Air flow to the Condenser
- 12. Minimum Clearance Electrical Panel Side
- (G) Centre of gravity

		SC-EXC			EN-EXC		
Size		352	402	432	352	402	432
M	mm	1933	1946	2011	1933	1946	2011
N	mm	1142	1129	1064	1142	1129	1064
O	mm	579	581	590	579	581	590
P	mm	518	516	507	518	516	507
OD	mm	76	76	76	76	76	76
Length	mm	3075	3075	3075	3075	3075	3075
Depth	mm	1097	1097	1097	1097	1097	1097
Height	mm	1805	1805	1805	1805	1805	1805
W1 Supporting Point	kg	149	153	156	149	153	156
W2 Supporting Point	kg	325	342	396	325	342	396
W3 Supporting Point	kg	161	165	168	161	165	168
W4 Supporting Point	kg	261	272	304	261	272	304
Shipping weight	kg	889	925	1015	889	925	1015
Operating weight	kg	896	933	1024	896	933	1024

The presence of optional accessories may result in a substantial variation of the weights shown in the table.

WSAT-XEE 452-502-552-602

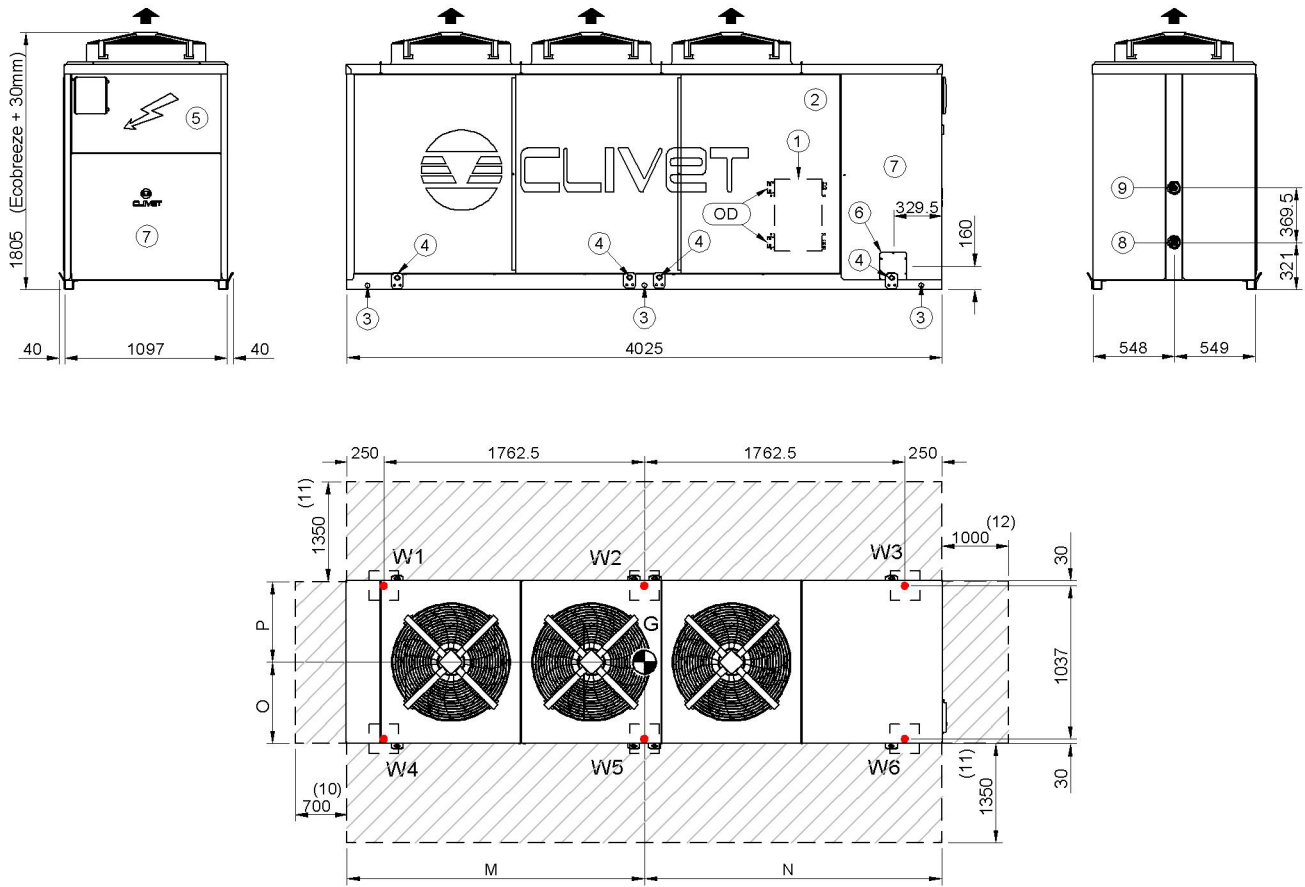

- 1. Internal exchanger (evaporator)
- 2. External exchanger (condenser)
- 3. Unit fixing holes
- 4. Lifting brackets (removable, if required, after positioning the unit)
- 5. Electrical panel
- 6. Power input
- 7. Soundproofed cabin
- 8. Internal exchanger water outlet. The heights of the connections may change if there are optional components: pump, storage tank, free-cooling, partial or total recovery.
- 9. Internal exchanger water inlet. The heights of the connections may change if there are optional components: pump, storage tank, free-cooling, partial or total recovery.
- 10. Minimum Safe Clearance
- 11. Minimum Clearance for a Proper Air flow to the Condenser
- 12. Minimum Clearance Electrical Panel Side
- (G) Centre of gravity

		SC-EXC				EN-EXC			
Size		452	502	552	602	452	502	552	602
M	mm	2553	2576	2574	2590	2553	2576	2574	2590
N	mm	1472	1449	1451	1435	1472	1449	1451	1435
O	mm	564	565	565	566	564	565	565	566
P	mm	533	532	532	531	533	532	532	531
OD	mm	76	76	76	76	76	76	76	76
Length	mm	4025	4025	4025	4025	4025	4025	4025	4025
Depth	mm	1097	1097	1097	1097	1097	1097	1097	1097
Height	mm	1805	1805	1805	1805	1805	1805	1805	1805
W1 Supporting Point	kg	80	80	82	84	80	80	82	84
W2 Supporting Point	kg	254	257	261	267	254	257	261	267
W3 Supporting Point	kg	287	301	306	323	287	301	306	323
W4 Supporting Point	kg	85	85	87	89	85	85	87	89
W5 Supporting Point	kg	253	255	259	265	253	255	259	265
W6 Supporting Point	kg	247	258	262	275	247	258	262	275
Shipping weight	kg	1198	1224	1246	1290	1198	1224	1246	1290
Operating weight	kg	1207	1234	1256	1302	1207	1234	1256	1302

The presence of optional accessories may result in a substantial variation of the weights shown in the table.

WSAT-XEE 702-802

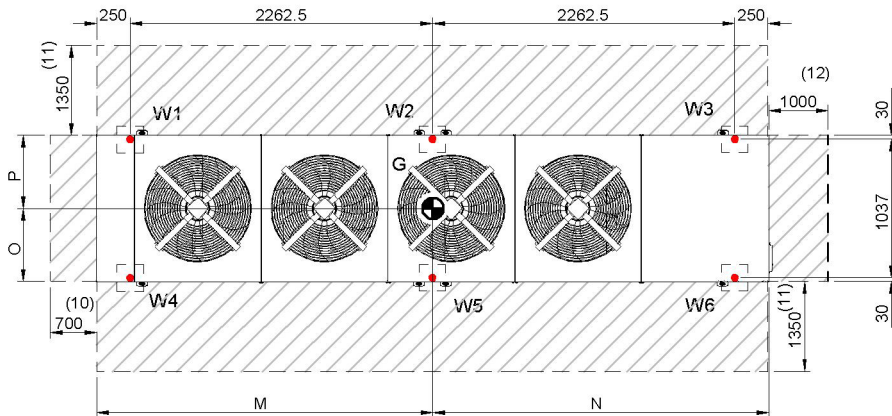
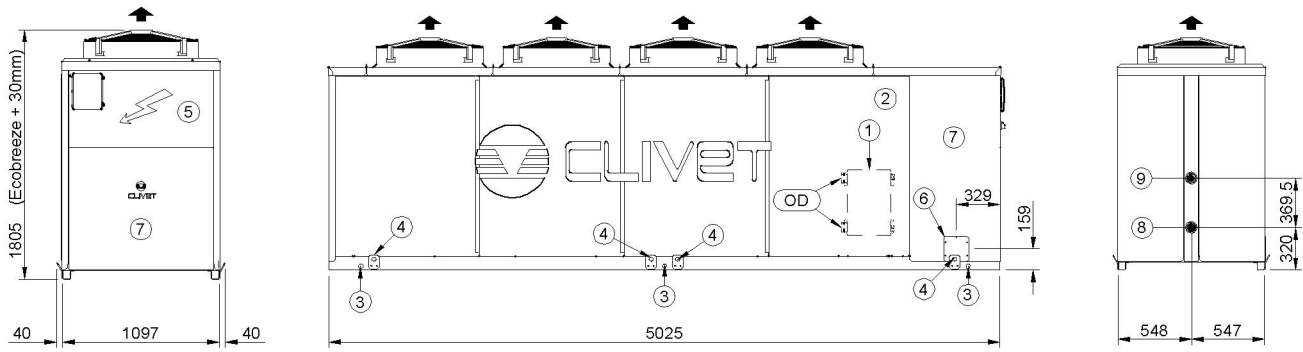

1. Internal exchanger (evaporator)
2. External exchanger (condenser)
3. Unit fixing holes
4. Lifting brackets (removable, if required, after positioning the unit)
5. Electrical panel
6. Power input
7. Soundproofed cabin
8. Internal exchanger water outlet. The heights of the connections may change if
9. Internal exchanger water inlet. The heights of the connections may change if there are optional components: pump, storage tank, free-cooling, partial or total recovery.
10. Minimum Safe Clearance
11. Minimum Clearance for a Proper Air flow to the Condenser
12. Minimum Clearance Electrical Panel Side
- (G) Centre of gravity

Size		SC-EXC		EN-EXC	
		702	802	702	802
M	mm	3216	3227	3216	3227
N	mm	1809	1798	1809	1798
O	mm	564	565	564	565
P	mm	533	532	533	532
OD	mm	76	76	76	76
Length	mm	5025	5025	5025	5025
Depth	mm	1097	1097	1097	1097
Height	mm	1805	1805	1805	1805
W1 Supporting Point	kg	114	115	114	115
W2 Supporting Point	kg	284	292	284	292
W3 Supporting Point	kg	374	389	374	389
W4 Supporting Point	kg	108	109	108	109
W5 Supporting Point	kg	306	315	306	315
W6 Supporting Point	kg	312	323	312	323
Shipping weight	kg	1483	1527	1483	1527
Operating weight	kg	1497	1544	1497	1544

The presence of optional accessories may result in a substantial variation of the weights shown in the table.

Dimensional drawings: Premium version

WSAT-XEE 352-402-432-452-502-552

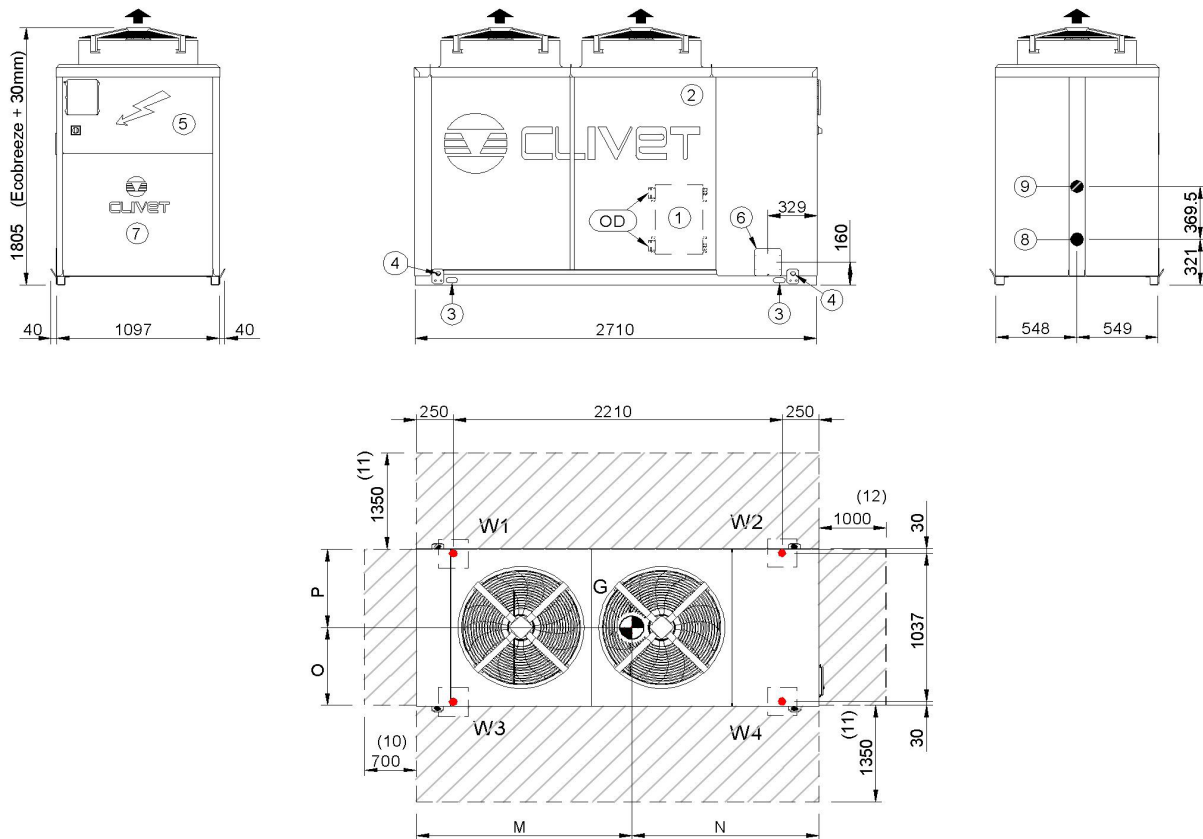

1. Internal exchanger (evaporator)
2. External exchanger (condenser)
3. Unit fixing holes
4. Lifting brackets (removable, if required, after positioning the unit)
5. Electrical panel
6. Power input
7. Soundproofed cabin
8. Internal exchanger water outlet. The heights of the connections may change if there are optional components: pump, storage tank, free-cooling, partial or total recovery.
9. Internal exchanger water inlet. The heights of the connections may change if there are optional components: pump, storage tank, free-cooling, partial or total recovery.
10. Minimum Safe Clearance
11. Minimum Clearance for a Proper Air flow to the Condenser
12. Minimum Clearance Electrical Panel Side
- (G) Centre of gravity

		SC-PRM						EN-PRM					
Size		352	402	432	452	502	552	352	402	432	452	502	552
M	mm	1637	1658	1724	1699	1704	1714	1637	1658	1724	1699	1704	1714
N	mm	1073	1052	986	1011	1006	996	1073	1052	986	1011	1006	996
O	mm	584	587	596	594	596	596	584	587	596	594	596	596
P	mm	513	510	501	503	501	501	513	510	501	503	501	501
OD	mm	76	76	76	76	76	76	76	76	76	76	76	76
Length	mm	2710	2710	2710	2710	2710	2710	2710	2710	2710	2710	2710	2710
Depth	mm	1097	1097	1097	1097	1097	1097	1097	1097	1097	1097	1097	1097
Height	mm	1805	1805	1805	1805	1805	1805	1805	1805	1805	1805	1805	1805
W1 Supporting Point	kg	138	138	141	152	158	159	138	138	141	152	158	159
W2 Supporting Point	kg	277	291	344	350	367	377	277	291	344	350	367	377
W3 Supporting Point	kg	152	153	155	166	172	173	152	153	155	166	172	173
W4 Supporting Point	kg	211	219	250	256	267	274	211	219	250	256	267	274
Shipping weight	kg	773	796	885	917	955	975	773	796	885	917	955	975
Operating weight	kg	778	802	892	924	963	984	778	802	892	924	963	984

The presence of optional accessories may result in a substantial variation of the weights shown in the table.

WSAT-XEE 602

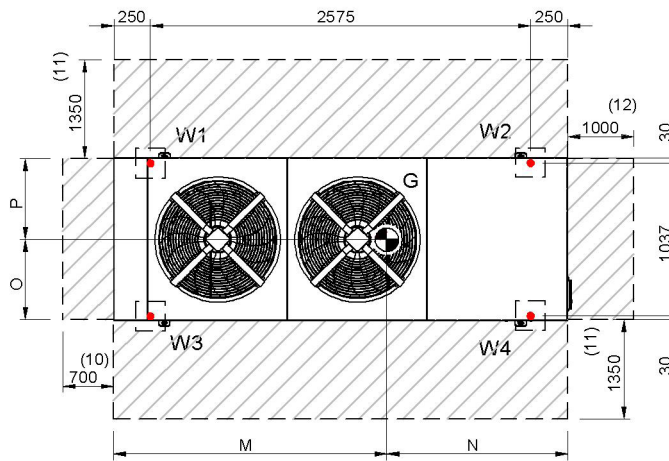
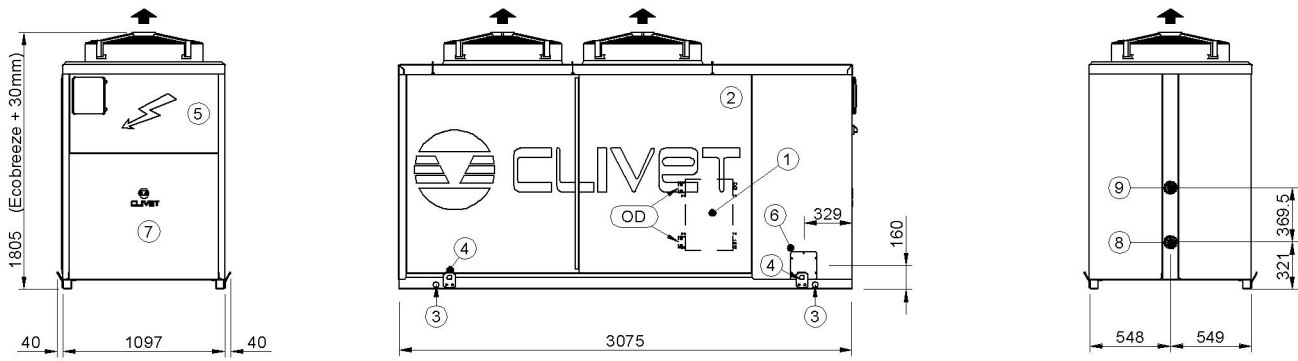

- 1. Internal exchanger (evaporator)
- 2. External exchanger (condenser)
- 3. Unit fixing holes
- 4. Lifting brackets (removable, if required, after positioning the unit)
- 5. Electrical panel
- 6. Power input
- 7. Soundproofed cabin
- 8. Internal exchanger water outlet. The heights of the connections may change if
- 9. Internal exchanger water inlet. The heights of the connections may change if there are optional components: pump, storage tank, free-cooling, partial or total recovery.
- 10. Minimum Safe Clearance
- 11. Minimum Clearance for a Proper Air flow to the Condenser
- 12. Minimum Clearance Electrical Panel Side
- (G) Centre of gravity

		SC-PRM	EN-PRM
Size		602	602
M	mm	2052	2052
N	mm	1023	1023
O	mm	595	595
P	mm	502	502
OD	mm	76	76
Length	mm	3075	3075
Depth	mm	1097	1097
Height	mm	1805	1805
W1 Supporting Point	kg	157	157
W2 Supporting Point	kg	434	434
W3 Supporting Point	kg	169	169
W4 Supporting Point	kg	326	326
W5 Supporting Point	kg	0.0	0.0
W6 Supporting Point	kg	0.0	0.0
Shipping weight	kg	1077	1077
Operating weight	kg	1087	1087

The presence of optional accessories may result in a substantial variation of the weights shown in the table.

WSAT-XEE 702-802

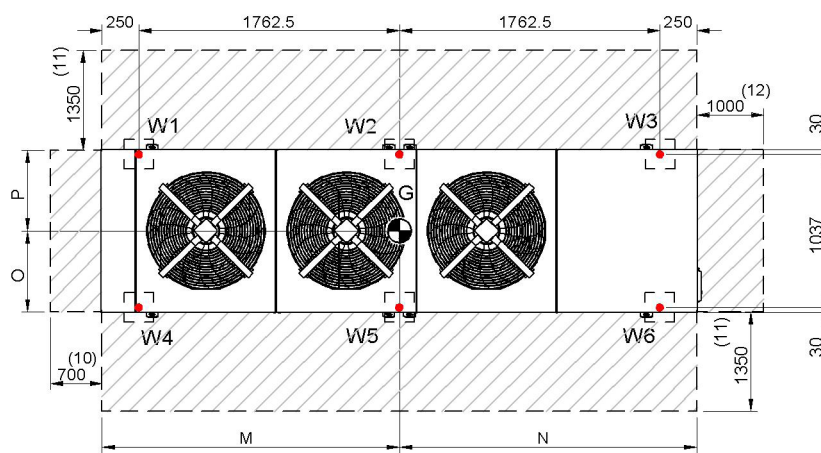
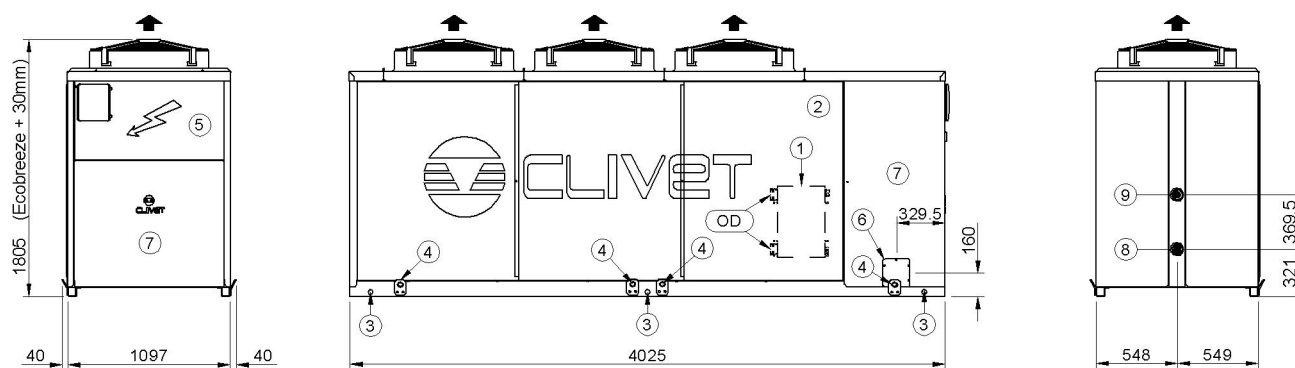

1. Internal exchanger (evaporator)
2. External exchanger (condenser)
3. Unit fixing holes
4. Lifting brackets (removable, if required, after positioning the unit)
5. Electrical panel
6. Power input
7. Soundproofed cabin
8. Internal exchanger water outlet. The heights of the connections may change if
9. Internal exchanger water inlet. The heights of the connections may change if there are optional components: pump, storage tank, free-cooling, partial or total recovery.
10. Minimum Safe Clearance
11. Minimum Clearance for a Proper Air flow to the Condenser
12. Minimum Clearance Electrical Panel Side
- (G) Centre of gravity

Size		SC-PRM		EN-PRM	
		702	802	702	802
M	mm	2626	2643	2626	2643
N	mm	1399	1382	1399	1382
O	mm	567	567	567	567
P	mm	530	530	530	530
OD	mm	76	76	76	76
Length	mm	4025	4025	4025	4025
Depth	mm	1097	1097	1097	1097
Height	mm	1805	1805	1805	1805
W1 Supporting Point	kg	79	79	79	79
W2 Supporting Point	kg	260	264	260	264
W3 Supporting Point	kg	332	344	332	344
W4 Supporting Point	kg	84	84	84	84
W5 Supporting Point	kg	258	262	258	262
W6 Supporting Point	kg	282	292	282	292
Shipping weight	kg	1283	1310	1283	1310
Operating weight	kg	1295	1324	1295	1324

The presence of optional accessories may result in a substantial variation of the weights shown in the table.

Page intentionally left blank

Page intentionally left blank



CLIVET SPA

Via Camp Lonc 25, Z.I. Villapaiera - 32032 Feltre (BL) - Italy
Tel. + 39 0439 3131 - Fax + 39 0439 313300 - info@clivet.it

CLIVET UK LTD (Sales)

4 Kingdom Close, Segensworth East - Fareham, Hampshire - PO15 5TJ - United Kingdom
Tel. + 44 (0) 1489 572238 - Fax + 44 (0) 1489 573033 - info@clivet-uk.co.uk

CLIVET AIRCON LTD (Service and Maintenance Division)

Units F5&F6 Railway Triangle Ind Est, Walton Road - Portsmouth, Hampshire - PO6 1TG - United Kingdom
Tel. +44 (0) 2392 381235 - Fax. +44 (0) 2392 381243 - info@clivetaircon.co.uk

CLIVET ESPAÑA COMERCIAL S.L. (Sales)

Calle Gurb, 17 1º 1ª - 08500 Vic, Barcelona - España
Tel: +34 93 8606248 - Fax +34 93 8855392 - info@clivetcomercial.com

CLIVET ESPAÑA S.A.U. (Service and Maintenance Division)

Calle Real de Burgos Nº 12 - 28860 Paracuellos del Jarama, Madrid - España
Tel. +34 91 6658280 - Fax +34 91 6657806 - info@clivet.es

CLIVET GmbH

Hummelsbütteler Steindamm 84, 22851 Norderstedt - Germany
Tel. + 49 (0) 40 32 59 57-0 - Fax + 49 (0) 40 32 59 57-194 - info.de@clivet.com

CLIVET RUSSIA

Elektrozavodskaya st. 24, office 509 - 107023, Moscow, Russia
Tel. + 74956462009 - Fax + 74956462009 - info.ru@clivet.com

CLIVET MIDEAST FZCO

Dubai Silicon Oasis (DSO), High Bay Complex, Ind Unit No. 3, PO BOX 342009, Dubai, UAE
Tel. + 9714 3208499 - Fax + 9714 3208216 - info@clivet.ae

CLIVET AIRCONDITIONING SYSTEMS PRIVATE LIMITED

4BA, Gundecha Onclave - Kherani Road, Saki Naka, Andheri (East) - Mumbai 400 072 - India
Tel. +91 22 6193 7000 - Fax +91 22 6193 7001 - info.in@clivet.com