

Centrifugal Fan Condensing Unit

INDEX

	Page
SAFETY CONSIDERATIONS	1
INSTALLATION	1
Step 1 — Check Equipment and Jobsite ...	1
• UNPACKAGE UNIT	1
• INSPECT EQUIPMENT	2
• COMPLETE OR CONSIDER SYSTEM REQUIREMENTS	2
Step 2 — Unit Support	2
• FLOORS AND FLOOR JOISTS	2
• TO SUSPEND UNIT	2
Step 3 — Make Ductwork Connections ...	2
• CONNECT SUPPLY AIR DUCTWORK	2
Step 4 — Provide for Unit Condensate Disposal	3
• BASEPAN DRAIN	3
Step 5 — Make Electrical Connections ...	3
• BRING LINE POWER LEADS INTO UNIT	3
• CONNECT CONTROL POWER WIRING	3
Step 6 — Make Piping Connections	4
• CONNECT REFRIGERANT LINES	4
START-UP	5
SERVICE	6

SAFETY CONSIDERATIONS

Installation and servicing of air conditioning equipment can be hazardous due to system pressure and electrical components. Only trained and qualified service personnel should install, repair or service air conditioning equipment.

Untrained personnel can perform basic maintenance functions of cleaning coils and filters and replacing filters. All other operations should be performed by trained service personnel. When working on air conditioning equipment, observe precautions in the literature, tags and labels attached to the unit and other safety precautions that may apply.

Follow all safety codes. Wear safety glasses and work gloves. Use quenching cloth for unbrazing operations.

WARNING: Before performing service or maintenance operations on unit, turn off main power switch to unit. Electrical shock could cause personal injury.

INSTALLATION

General — Install the 38JB condensate unit indoors. Provide access for cleaning and servicing as shown in Fig. 1. Use field-supplied condenser air filters for proper unit operation.

Step 1 — Check Equipment and Jobsite

UNPACKAGE UNIT — Move to final location. Use care as unit is heavy and awkward to handle. Carefully remove from carton so as not to damage unit.

Table 1 — Physical Data

UNIT 38JB	016	024
OPERATING WEIGHT (lb)	1060	1370
REFRIGERANT Charge (lb)	13	9*
COMPRESSOR(S) Oil, PP33-2 (pt), See Note	10	10 (ea)
CONDENSER AIR FANS	Centrifugal, Belt Drive	
Motor, Hp...Rpm	5 1750	
Motor Frame (NEMA)	213T	
Motor Pulley Pitch Diameter Range (in.)	5 5-6 5	
Fan Pulley Pitch Diameter (in)	7 8	
Belt; No —Designation	1-B57	
Belt Pitch Length (in)	57	
Fan Factory Setting (Rpm)	1370	
Fan Range (Rpm)	1220-1460	
Max Allowable Fan Speed (Rpm)	1600‡	
Speed change per 1/2 turn of movable motor pulley flange	30	
Movable pulley factory setting full turns open	1-1/2	
Max allowable full turns from closed position	4	
PRESSURESTAT	Factory Settings; psig	
High Cutout	375 ± 5	428 ± 4
Low Cutout	29 ± 5	29 ± 2
Low Cut-in	39 ± 3	39 ± 3

*Each system

†One on 016; 2 on 024

‡Not attainable with factory-supplied pulley

NOTE Approved vendors and designations —

Sun Oil Company

Texaco, Inc

E I DuPont Company

Suniso 3GS

Capella BI

DuPont Synthetic Refrigeration Oil

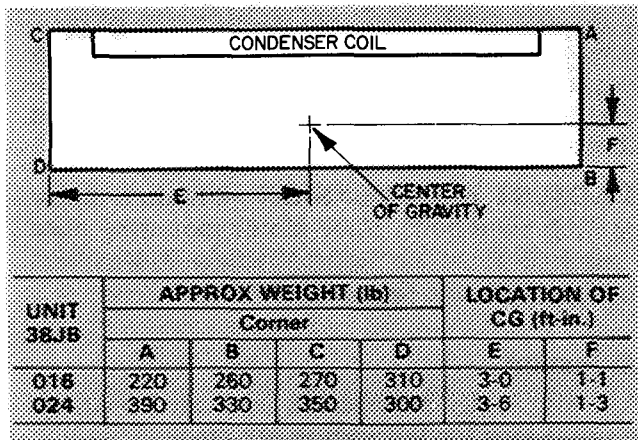

Fig. 2 — Weight Distribution

vapor barrier. If ducts are not insulated, install dampers in wall openings to prevent cold air from entering ducts and unit. Insulate inside of duct within 12 in. (minimum) of unit. Also insulate bottom of unit (basepan) to prevent condensation from forming on unit if unit is installed off the floor.

Install louvers in wall openings to prevent rain from entering ducts and unit. Arrange louvers or other air deflection baffles to prevent recirculation of outdoor airflow thru condenser.

If condenser air inlet filters are not used, provide an access door in condenser air inlet duct for coil cleaning.

Step 4 — Provide for Unit Condensate Disposal

BASEPAN DRAIN — Trap 1/2-in. diameter drain in unit basepan for proper condensate disposal, see Fig. 3. Refer to Carrier System Design Manual, Part 3 for additional trap design details.

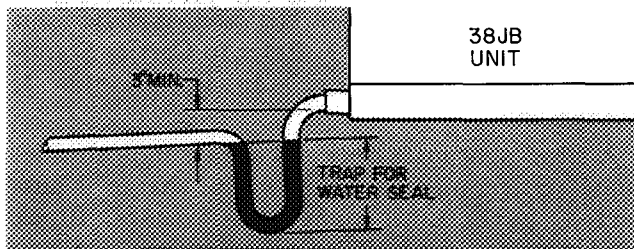

Fig. 3 — Trap for Drain

Step 5 — Make Electrical Connections

WARNING: To prevent electrical shock or equipment damage, make sure disconnects are open before electrical connections are made. If this action is not taken, personal injury may occur.

Field wiring must comply with local and national fire, safety and electrical codes. Voltage to unit must be within 2% of voltage and 10% of current as indicated on nameplate. See Table 2.

Contact local power company for correction of improper line voltage.

Operation of unit on improper line voltage constitutes abuse and is not covered by Carrier warranty.

BRING LINE POWER LEADS INTO UNIT — Install airtight conduit connectors in side panel knockouts. Route all wires thru connectors to terminal blocks in control box. Refer to Fig. 4 and unit label diagram. Use copper, copper-clad aluminum, or aluminum wire from power supply. If aluminum wire is used, coat wire ends with a corrosive inhibiting flux. Install unit ground.

CONNECT CONTROL POWER WIRING — See Fig. 4. Make field power wire connections to terminal board (TB1).

Connect field-supplied thermostat to terminal board (TB2). Terminals C and G are provided for field-supplied indoor fan relay connections. Operate thermostat and indoor fan relay on 24 volts.

The 38JB016 has a third terminal board (TB3) for 115-volt liquid line solenoid valve connections. Use 7/8-in. diameter knockout. See Fig. 1 for wiring liquid line solenoid valve into control box.

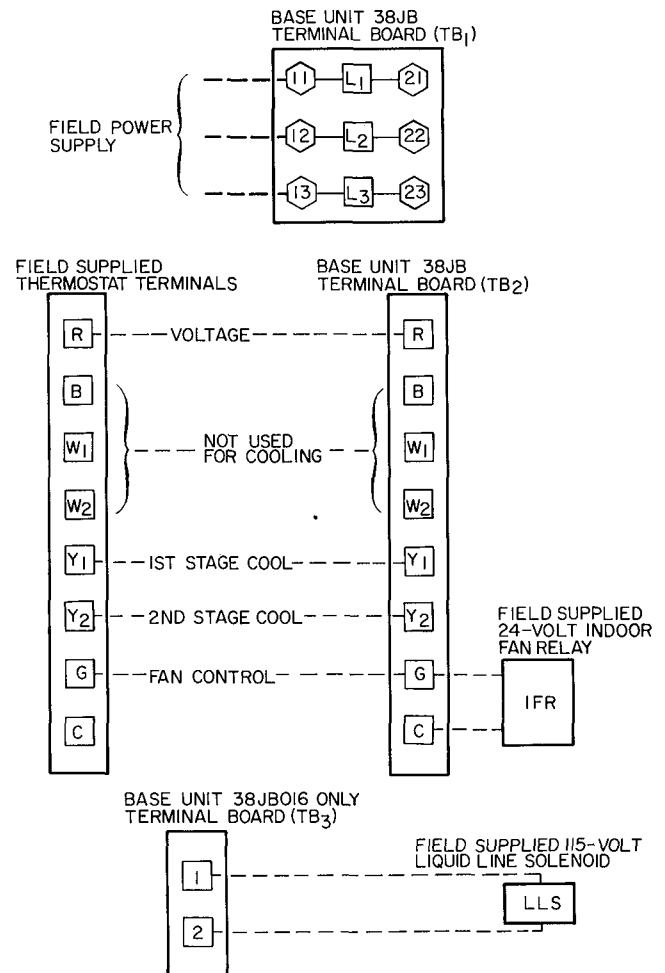

Fig. 4 — Electrical Connections

Table 2 — Electrical Data (60-Hz, 3-Ph)

UNIT		VOLTS*			COMPRESSOR		FAN		UNIT POWER SUPPLY†	
38JB	Model	Nameplate	Min	Max	RLA	LRA	FLA	Kw	MCA	Max Fuse Amps
016	520	208-230	187	254	64.0	266	16.2	3.73	97.5	150
	610	460	414	508	28.6	120	7.1	3.73	43.4	70
	110	575	518	632	23.6	96	5.6	3.73	35.6	50
024	520	208-230	187	254	44.3	170	16.2	3.73	117.0	150
	610	460	414	508	20.0	77	7.1	3.73	52.6	70
	110	575	518	632	15.7	62	5.6	3.73	41.5	50

FLA — Full Load Amps (fan motor)
 Kw — Total Kilowatts
 LRA — Locked Rotor Amps
 MCA — Minimum Circuit Amps Complies with NEC, Section 430-24
 RLA — Rated Load Amps (compressor)

*Units are suitable for use on electrical systems where voltage supplied to the unit terminal block is not below minimum or above maximum

†Fuse only
 NOTES

1. Control circuit breaker size is 3.2 amps for all units
2. Unit 38JB024 has 2 compressors; RLA and LRA values apply for each

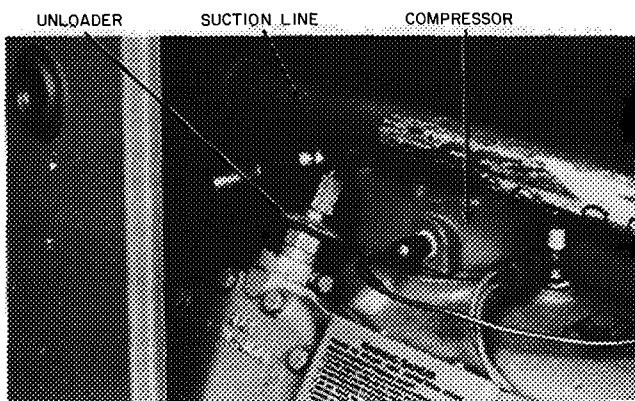

38JB016

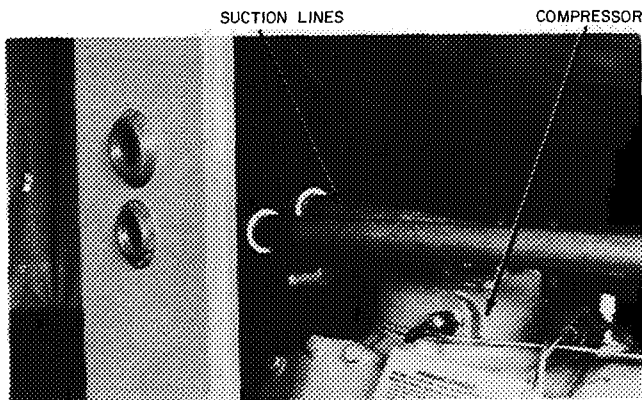

38JB024

Fig. 5 — Piping Connections

Step 6 — Make Piping Connections

Connect condensing unit to a fan coil unit using field-supplied refrigerant grade tubing. Do not use damaged or contaminated tubing. Evacuate and purge field-supplied tubing.

The 38JB is shipped with a holding charge in the condensing coil and compressor. When using head pressure dampers, connect line to head pressure-

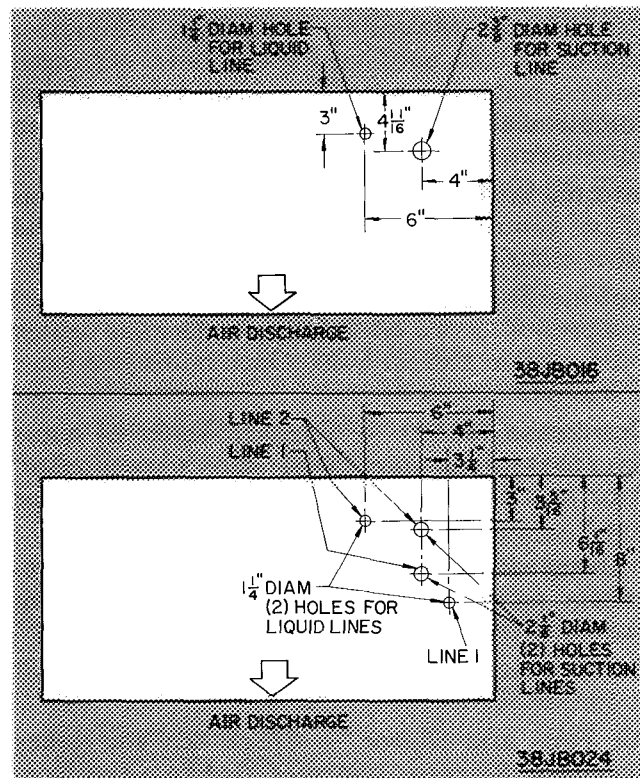

Fig. 6 — Liquid and Suction Line Locations in Top Panel

actuated piston operator prior to pumping system down. Evacuate remainder of system before charging.

CONNECT REFRIGERANT LINES — See Fig. 5. When suction lines are piped thru the front or top of the 38JB016, one 1-3/8 in. 90° elbow is required; two 1-1/8 in. 90° elbows are required on the 38JB024. See Fig. 6 for hole locations.

When liquid lines are piped thru the front of unit elbows are not required. When liquid lines are piped thru top of unit, two 5/8-in. 90° elbows are required. See Fig. 1 and Fig. 6 for line locations.

NOTE: Shorten 38JB024 compressor no. 2 liquid line by 5 inches. Compressor refrigeration systems on the 38JB024 cannot be interconnected.

For piping instructions, refer to the Carrier System Design Manual. Refer to Refrigerant Charge and Carrier's Standard Service Techniques, Chapter 1, Refrigerants, when charging unit.

START-UP

Make sure unit has been installed in accordance with installation instructions and all applicable codes. Check the following items before starting unit.

Compressor Mounting — Loosen compressor hold-down bolts until sidewise movement of flanged washers under bolt heads is possible. Do not loosen completely. Bolts are self-locking and retain adjustment.

Internal Wiring — Check all electrical connections in unit control box, compressor terminal boxes and other electrical components. Tighten as required.

Refrigerant Shutoff Valves — Open (backseat) compressor service valves fully. Replace and tighten valve caps to prevent leaks. Open liquid line valve in a similar manner.

Crankcase Heater — Energize heater 24 hours prior to start-up to prevent loss of oil in compressor. Area near heater element should be warm to the touch.

Heater is automatically energized when compressor is stopped and de-energized when compressor is operating.

Compressor Oil Sight Glass should be 1/2 full of oil. See Service; Lubrication.

Air Fans and Motor — Check belt and pulley alignment. Refer to Condenser Air Fan Adjustment as required.

Cooling — To start unit, turn on main power supply. See Crankcase Heater above. Set thermostat to COOL, AUTO, and desired temperature. Wait approximately 5 minutes for compressor to start. See Time Guard® Circuit. Check cooling effect at air supply grilles, fan speeds, refrigerant sight-glass conditions and operation of all controls and safety devices.

Accessory Head Pressure Control — A head pressure-actuated piston operator, connected to a damper, regulates airflow thru the condenser. At 170 F psig discharge pressure, damper starts to open. Damper is fully open (horizontal position) at 250 psig.

Pressure Switches (high and low) cut out at settings shown in Table 1.

Time Guard® Circuit provides a delay before starting compressor after shutdown. At start-up, timer delays compressor for 12 seconds after thermostat closes. On compressor shutdown, timer recycles for 5-1/2 minutes. During this period, compressor cannot restart. On 38JB024, timers are set for a 12-second delay between start-up of compressor no. 1 and compressor no. 2.

Winter Start — Timer overrides low-pressure switch for 2-1/2 minutes. During start-up at low ambient conditions, this permits system suction pressure to reach normal operating level. On a sustained low-pressure condition, the timer circuit shuts down until low-pressure switch resets.

Capacity Control — Two-step thermostat assembly cycles each of 2 compressors on 38JB024. On 38JB016, first stage of thermostat cycles compressor; second stage of the thermostat can be used to operate a field-supplied liquid line solenoid for 2-stage operation. Compressor capacity control unloader responds to suction pressure changes.

Compressor Capacity Control Unloader (Fig. 7) is suction-pressure actuated and controls 2 cylinders. Unloader is factory set to unload at 60 psig and load at 75 psig but may be field adjusted as follows:

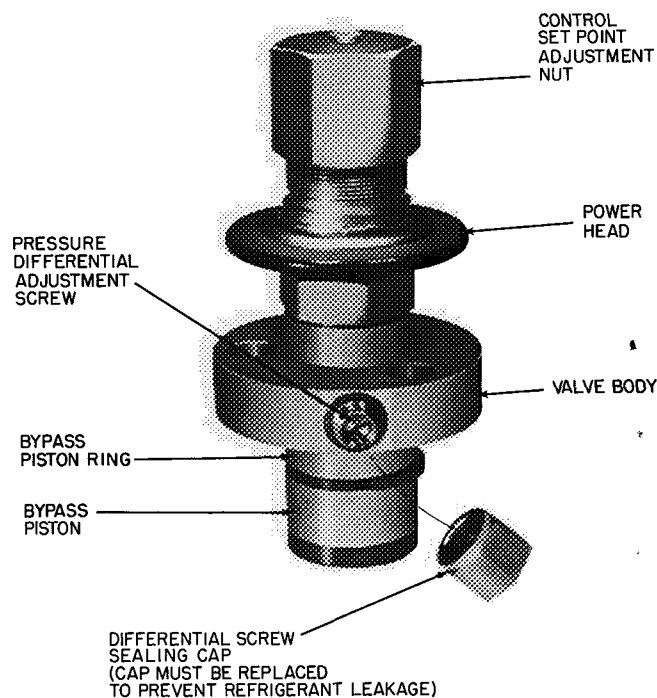

Fig. 7 — Compressor Capacity Control Unloader

CONTROL SET POINT (cylinder load point) is adjustable from 0 to 85 psig. To adjust, turn control set point adjustment clockwise to its bottom stop. In this position, load point is 85 psig. Turn adjustment counterclockwise to desired load point.

Every full turn counterclockwise decreases load point by 7.5 psig.

PRESSURE DIFFERENTIAL (difference between cylinder load and unload points) is adjustable from 6 to 22 psig. To adjust, turn pressure differential adjustment counterclockwise to its back stop position. In this position, differential is 6 psig. Turn adjustment clockwise to desired pressure differential. Every full turn clockwise increases differential by 1.5 psig.

SERVICE

Turn off main power before servicing unit.

Condenser Coil — Remove dirt and debris from coil as required. Clean with a stiff brush, vacuum cleaner or compressed air.

Condenser Air Fan Adjustment — Speed (see Table 1) and alignment is factory set, adjust as follows:

TO CHANGE FAN SPEED:

1. Loosen fan belt by loosening fan motor mounting plate bolts.
2. Loosen pulley movable flange setscrews (Fig. 8).
3. Screw movable flange toward fixed flange to increase speed and away from fixed flange to decrease speed.

Increasing fan speed increases load on motor. Do not exceed maximum fan speeds (Table 1).

4. Tighten movable flange setscrews at nearest flat surface of pulley hub.

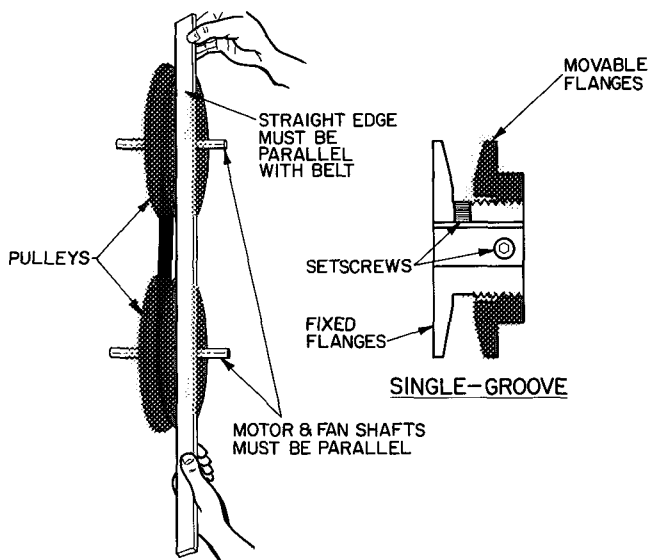

Fig. 8 — Pulley Adjustment

TO ALIGN FAN AND MOTOR PULLEYS — Loosen fan pulley setscrews and slide fan pulley along fan shaft. Make angular alignment by loosening motor from mounting plate. Check alignment with a straight edge (Fig. 8).

TO ADJUST BELT TENSION — Loosen motor mounting plate bolts. Slide motor mounting plate as required to attain approximately 3/4-in. belt deflection with one finger.

Lubrication

FAN MOTORS have sealed lubricated bearings. No provisions for lubrication are made.

FAN SHAFT BEARINGS have been factory greased. After first 6 months of unit operation, regrease twice a year, preferably prior to each heating and cooling season. Add grease slowly with shaft revolving until grease rapidly oozes from pressure relief hole in grease fitting.

COMPRESSOR has its own oil supply. Loss of oil due to a leak in the system should be the only reason for adding oil after the system has been in operation. Sight glass should be 1/2 full of oil.

To Add or Remove Compressor Oil

1. Pump down compressor to 2 psig and close suction and discharge service valves. Vent remaining pressure in compressor to atmosphere.
2. Add oil thru oil filler connection.
3. To remove oil, remove compressor crankcase oil drain plug.

Refer to Standard Service Techniques Manual, Chapter 1, or 06D Compressor Service Instructions for complete instructions on checking, adding or removing compressor oil.

Refrigerant Charge — The approximate unit charge is listed in Table 1. Refer to Carrier Standard Service Techniques Manual, Chapter 1, Refrigerants.

A clear sight glass does not always indicate adequate refrigerant charge. If a low charge is suspected, purge until sight glass flashes. Block condenser coil air inlets to maintain 300 ± 5 psig discharge pressure. Charge slowly until sight glass clears, then add an additional charge as specified in the instructions for the evaporator unit.

If low-pressure switch is jumpered for charging, remove jumper.

For replacement items use Carrier Specified Parts.

Manufacturer reserves the right to discontinue, or change at any time, specifications or designs without notice and without incurring obligations.

Book	1
Tab	3a

Form 38JB-3SI Supersedes 38JB-1SI

Printed in U S A

9-80

PC 111

Catalog No 533-889