



# 30RA 040-240 "B" Air-Cooled Liquid Chillers with Integrated Hydronic Module

Nominal cooling capacity 39-245 kW

50 Hz

PRO-DIALOG *PLUS*

AQUASNAP



Carrier is participating in the Eurovent Certification Programme. Products are as listed in the Eurovent Directory of Certified Products.

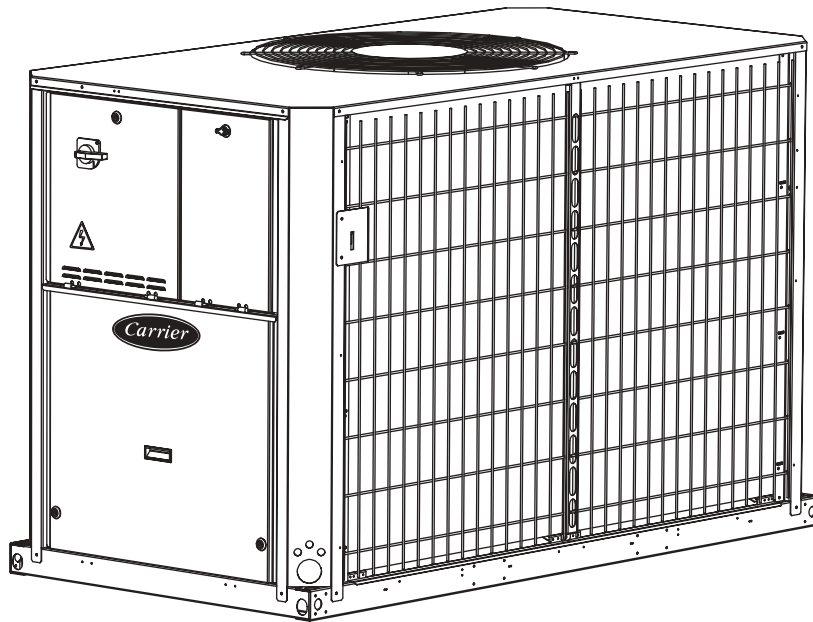

For the operation of the control please refer to the Pro-Dialog *PLUS* Control manual for the 30RA/RH - RY/RYP "B" series



## Installation, operation and maintenance instructions



Quality Management System Approval

**The drawings in this document are for illustrative purposes only and is not part of any offer for sale or contract.**

# CONTENTS

<b>1 - INTRODUCTION</b> .....	<b>4</b>
1.1 - Installation safety considerations .....	4
1.2 - Equipment and components under pressure .....	4
1.3 - Maintenance safety considerations .....	5
1.4 - Repair safety considerations .....	5
<b>2 - PRELIMINARY CHECKS</b> .....	<b>7</b>
2.1 - Check equipment received .....	7
2.2 - Moving and siting the unit .....	7
<b>3 - DIMENSIONS/CLEARANCES</b> .....	<b>9</b>
<b>4 - PHYSICAL DATA</b> .....	<b>11</b>
<b>5 - ELECTRICAL DATA</b> .....	<b>11</b>
<b>6 - APPLICATION DATA</b> .....	<b>14</b>
6.1 - Unit operating range .....	14
6.2 - Evaporator water flow rates .....	14
6.3 - Minimum water flow rate .....	14
6.4 - Maximum evaporator water flow rate .....	14
6.5 - Water loop volume .....	14
6.6 - Unit operating range at full and part load .....	15
6.7 - Pressure drop in the plate heat exchangers .....	15
<b>7 - ELECTRICAL CONNECTION</b> .....	<b>16</b>
7.1 - Control box .....	16
7.2 - Power supply .....	17
7.3 - Voltage phase imbalance (%) .....	17
<b>8 - RECOMMENDED WIRE SECTIONS</b> .....	<b>18</b>
8.1 - Field control wiring .....	18
<b>9 - WATER CONNECTIONS</b> .....	<b>19</b>
9.1 - Operating precautions and recommendations .....	19
9.2 - Hydronic connections .....	20
9.3 - Frost protection .....	20
<b>10 - NOMINAL SYSTEM WATER FLOW CONTROL</b> .....	<b>22</b>
10.1 - Water flow control procedure .....	22
10.2 - Pump pressure/flow rate curves .....	24
10.3 - Available static system pressure .....	25
<b>11 - START-UP</b> .....	<b>26</b>
11.1 - Preliminary checks .....	26
11.2 - Actual start-up .....	26
11.3 - Operation of two units in master/slave mode .....	26
<b>12 - MAINTENANCE</b> .....	<b>27</b>
12.1 - General maintenance of the refrigerant circuit .....	27
12.2 - Refrigerant charge .....	27
12.3 - Electrical maintenance .....	28
12.4 - Condenser coil .....	29
<b>13 - AQUASNAP MAINTENANCE PROGRAM</b> .....	<b>30</b>
13.1 - Maintenance schedule .....	30
13.2 - Description of the maintenance operations .....	30
<b>14 - START-UP CHECKLIST FOR 30RA LIQUID CHILLERS (USE FOR JOB FILE)</b> .....	<b>32</b>

## 1 - INTRODUCTION

Prior to the initial start-up of the 30RA units, the people involved in the on-site installation, start-up, operation, and maintenance of this unit should be thoroughly familiar with these instructions and the specific project data for the installation site.

The 30RA liquid chillers are designed to provide a very high level of safety during installation, start-up, operation and maintenance. They will provide safe and reliable service when operated within their application range.

This manual provides the necessary information to familiarize yourself with the control system before performing start-up procedures. The procedures in this manual are arranged in the sequence required for machine installation, start-up, operation and maintenance.

Be sure you understand and follow the procedures and safety precautions contained in the instructions supplied with the machine, as well as those listed in this guide.

Earthquake resistance has not been verified for these units.

### 1.1 - Installation safety considerations

This machine must be installed in a location that is not accessible to the public and protected against access by non-authorized people.

After the unit has been received, when it is ready to be installed or reinstalled, and before it is started up, it must be inspected for damage. Check that the refrigerant circuit(s) is (are) intact. Ensure especially that no components or pipes have shifted (e.g. following a shock). If in doubt, carry out a leak tightness check and verify with the manufacturer that the circuit integrity has not been impaired. If damage is detected upon receipt, immediately file a claim with the shipping company.

***Do not remove the skid or the packaging until the unit is in its final position. These units can be moved with a fork lift truck, as long as the forks are positioned in the right place and direction on the unit.***

***The units can also be lifted with slings, using only the designated lifting points marked at the four corners at the unit base.***

***These units are not designed to be lifted from above. Use slings with the correct capacity, and always follow the lifting instructions on the certified drawings supplied with the unit.***

***Safety is only guaranteed, if these instructions are carefully followed. If this is not the case, there is a risk of material deterioration and injuries to personnel.***

***Never cover any safety devices.***

***This applies to the globe valve in the water circuit and the globe valve(s) in the refrigerant circuit(s).***

***Ensure that the valves are correctly installed, before operating the unit.***

***In certain cases the globe stops are installed on ball valves. These valves are factory-supplied lead-sealed in the open position. This system permits isolating and removing the globe stop for checking and replacing. The globe stops are designed and installed to ensure protection against fire risk. Removing the globe stops is only permitted if the fire risk is fully controlled and the responsibility of the user.***

***All factory-installed globe valves are lead-sealed to prevent any calibration change. If the globe valves are installed on a reversing valve (change-over), this is equipped with a globe valve on each of the two outlets. Only one of the two globe valves is in operation, the other one is isolated. Never leave the reversing valve in the intermediate position, i.e. with both ways open (locate the control element in the stop position). If a globe stop is removed for checking or replacement please ensure that there is always an active globe stop on each of the reversing valves installed in the unit.***

***Provide a drain in the discharge circuit, close to each valve, to avoid an accumulation of condensate or rain water.***

***The safety valves must be connected to discharge pipes. These pipes must be installed in a way that ensures that people and property are not exposed to refrigerant leaks. These fluids may be diffused in the air, but far away from any building air intake, or they must be discharged in a quantity that is appropriate for a suitably absorbing environment.***

***Periodic check of the globe valves: See paragraph "Maintenance safety considerations".***

***Accumulation of refrigerant in an enclosed space can displace oxygen and cause asphyxiation or explosions.***

***Inhalation of high concentrations of vapour is harmful and may cause heart irregularities, unconsciousness, or death. Vapour is heavier than air and reduces the amount of oxygen available for breathing. These products cause eye and skin irritation. Decomposition products are hazardous.***

### 1.2 - Equipment and components under pressure

These products incorporate equipment or components under pressure, manufactured by Carrier or other manufacturers. We recommend that you consult your appropriate national trade association or the owner of the equipment or components under pressure (declaration, re-qualification, retesting, etc.). The characteristics of this equipment/these components are given on the nameplate or in the required documentation, supplied with the products.

Do not introduce high static and dynamic pressure compared with the existing operating pressures - either service or test pressures in the refrigerant circuit or in the heat transfer circuit, especially:

- limiting the elevation of the condensers or evaporators
- taking the circulating pumps into consideration.

### 1.3 - Maintenance safety considerations

Engineers working on the electric or refrigeration components must be authorized and fully qualified to do so (electricians trained and qualified in accordance with IEC 60364 Classification BA4).

All refrigerant circuit repairs must be carried out by a trained person, fully qualified to work on these units. He must have been trained and be familiar with the equipment and the installation, and he must wear the necessary protective items (gloves, glasses, protective clothes, safety shoes).

Soldering and welding: Component, piping and connection soldering and welding operations must be carried out using the correct procedures and by qualified operators. Pressurised containers must not be subjected to shocks, nor to large temperature variations during maintenance and repair operations.

***Never work on a unit that is still energized.***

***Never work on any of the electrical components, until the general power supply to the unit has been cut using the disconnect switch in the control box.***

***If any maintenance operations are carried out on the unit, lock the power supply circuit in the open position ahead of the machine.***

***If the work is interrupted, always ensure that all circuits are still deenergized before resuming the work.***

***ATTENTION: Even if the unit has been switched off, the power circuit remains energized, unless the unit or circuit disconnect switch is open. Refer to the wiring diagram for further details. Attach appropriate safety labels.***

***Operating checks: During the life-time of the system, inspection and tests must be carried out in accordance with national regulations.***

***The information on operating inspections given in annex C of standard EN378-2 can be used if no similar criteria exist in the national regulations.***

***Safety device checks (annex C6 – EN378-2): The safety devices must be checked on site once a year for safety devices (high-pressure switches), and every five years for external overpressure devices (safety globe valves).***

***Contact Carrier Service for a detailed explanation of the high-pressure switch test method.***

***If the machine operates in a corrosive environment, inspect the protection devices more frequently.***

***Regularly carry out leak tests and immediately repair any leaks.***

### 1.4 - Repair safety considerations

All installation parts must be maintained by the personnel in charge, in order to avoid material deterioration and injuries to people. Faults and leaks must be repaired immediately. The authorized technician must have the responsibility to repair the fault immediately. Each time repairs have been carried out to the unit, the operation of the safety devices must be re-checked.

If a leak occurs or if the refrigerant becomes polluted (e.g. by a short circuit in a motor) remove the complete charge using a recovery unit and store the refrigerant in mobile containers (careful in case the refrigerant decomposes due to high temperature increases, as the decomposition products are dangerous).

If a leak occurs, evacuate all refrigerant, repair the leak detected and recharge the circuit with the total R407C charge, as indicated on the unit name plate. Never top up the charge. Only charge liquid refrigerant R407C at the liquid line.

***The 30RA 040 to 240 units use R407C refrigerant. These units are essentially sold in Europe, and their operating range is limited to an outside air temperature of approximately 45°C.***

***Always ensure you are using the correct refrigerant type before recharging the unit.***

***Charging any refrigerant other than the original charge type (R407C) will impair machine operation and can even lead to a destruction of the compressors. The compressors operating with R407C are charged with a synthetic polyolester oil.***

***R407C units have a hermetic refrigerant circuit and the original charge needs not be topped up, as R407C is a zeotropic refrigerant.***

***Do not use oxygen to purge lines or to pressurize a machine for any purpose. Oxygen gas reacts violently with oil, grease, and other common substances.***

***Never exceed the specified maximum operating pressures. Verify the allowable maximum high- and low-side test pressures by checking the instructions in this manual and the pressures given on the unit name plate.***

***Do not use air for leak testing. Use only refrigerant or dry nitrogen.***

***Do not unweld or flame-cut the refrigerant lines or any refrigerant circuit component until all refrigerant (liquid and vapour) has been removed from chiller. Traces of vapour should be displaced with dry air nitrogen. Refrigerant in contact with an open flame produces toxic gases.***

***The necessary protection equipment must be available, and appropriate fire extinguishers for the system and the refrigerant type used must be within easy reach.***

***Do not siphon refrigerant.***

*Avoid spilling liquid refrigerant on skin or splashing it into the eyes. Use safety goggles. Wash any spills from the skin with soap and water. If liquid refrigerant enters the eyes, immediately and abundantly flush the eyes with water and consult a doctor.*

*Never apply an open flame or live steam to a refrigerant container. Dangerous overpressure can result. If it is necessary to heat refrigerant, use only warm water.*

*During refrigerant removal and storage operations follow applicable regulations. These regulations, permitting conditioning and recovery of halogenated hydrocarbons under optimum quality conditions for the products and optimum safety conditions for people, property and the environment are described in standard NFE 29795.*

*Any refrigerant transfer and recovery operations must be carried out using a transfer unit. A 3/8" SAE connector on the manual liquid line valve is supplied with all units for connection to the transfer station. The units must never be modified to add refrigerant and oil charging, removal and purging devices. All these devices are provided with the units. Please refer to the certified dimensional drawings for the units.*

*Do not re-use disposable (non-returnable) cylinders or attempt to refill them. It is dangerous and illegal. When cylinders are empty, evacuate the remaining gas pressure, and move the cylinders to a place designated for their recovery. Do not incinerate.*

*Do not attempt to remove refrigerant circuit components or fittings, while the machine is under pressure or while it is running. Be sure pressure is at 0 kPa before removing components or opening a circuit.*

*Any manipulation (opening or closing) of a shut-off valve must be carried out by a qualified and authorised engineer. These procedures must be carried out with the unit shut-down.*

*NOTE: The unit must never be left shut down with the liquid line valve closed, as liquid refrigerant can be trapped between this valve and the expansion device. (This valve is situated on the liquid line before the filter drier box.)*

*Do not attempt to repair or recondition any safety devices when corrosion or build-up of foreign material (rust, dirt, scale, etc.) is found within the valve body or mechanism. If necessary, replace the device. Do not install safety valves in series or backwards.*

#### **CAUTION**

*Do not step on refrigerant lines. The lines can break under the weight and release refrigerant, causing personal injury.*

*No part of the unit must use feet, racks or supports during operation. Periodically monitor and repair or if necessary replace any component or piping that shows signs of damage.*

*Do not climb on a machine. Use a platform, or staging to work at higher levels.*

*Use mechanical lifting equipment (crane, hoist, etc.) to lift or move heavy components such as compressors or plate heat exchangers. For lighter components, use lifting equipment when there is a risk of slipping or losing your balance.*

*Use only original replacement parts for any repair or component replacement. Consult the list of replacement parts that corresponds to the specification of the original equipment.*

*Do not drain water circuits containing industrial brines, without informing the technical service department at the installation site or a competent body first.*

*Close the entering and leaving water shutoff valves and purge the unit hydronic circuit, before working on the components installed on the circuit (screen filter, pump, water flow switch, etc.).*

*Periodically inspect all valves, fittings and pipes of the refrigerant and hydronic circuits to ensure that they do not show any corrosion or any signs of leaks.*

## 2 - PRELIMINARY CHECKS

### 2.1 - Check equipment received

- Inspect the unit for damage or missing parts. If damage is detected, or if shipment is incomplete, immediately file a claim with the shipping company.
- Confirm that the unit received is the one ordered. Compare the name plate data with the order.
- The unit name plate must include the following information:
  - Version number
  - Model number
  - CE marking
  - Serial number
  - Year of manufacture and test date
  - Refrigerant used and refrigerant class
  - Refrigerant charge per circuit
  - Containment fluid to be used
  - PS: Min./max. allowable pressure (high and low pressure side)
  - TS: Min./max. allowable temperature (high and low pressure side)
  - Globe valve cut-out pressure
  - Pressure switch cut-out pressure
  - Unit leak test pressure
  - Voltage, frequency, number of phases
  - Maximum current drawn
  - Maximum power input
  - Unit net weight

	High pressure		Low pressure	
	Min.	Max.	Min.	Max.
PS (bar)	-0.9	32	-0.9	25
TS (°C)	-20	72	-20	62
Pressure switch cut-out pressure (bar)	29		-	
Valve cut-out pressure (bar)	32		25	
Test pressure, unit leak test (bar)	15			

- Confirm that all accessories ordered for on-site installation have been delivered, and are complete and undamaged.
- The unit must be checked periodically during its whole operating life to ensure that no shocks (handling accessories, tools etc.) have damaged it. If necessary, the damaged parts must be repaired or replaced. See also chapter "Maintenance".

## 2.2 - Moving and siting the unit

### 2.2.1 - Moving

*See chapter "Installation safety considerations"*

### 2.2.2 - Siting the unit

*Always refer to the chapter "Dimensions and clearances" to confirm that there is adequate space for all connections and service operations. For the centre of gravity coordinates, the position of the unit mounting holes, and the weight distribution points, refer to the certified dimensional drawing supplied with the unit.*

**CAUTION:** *Only use slings at the designated lifting points which are marked on the unit.*

Before siting the unit check that:

- the permitted loading at the site is adequate or that appropriate strengthening measures have been taken.
- the surface is horizontal, flat and intact.
- there is adequate space above the unit for air flow.
- there are adequate support points and that they are in the right places.
- the location is not subject to flooding.
- where heavy snowfall is likely and long periods of sub-zero temperatures are normal, provision has been made to prevent snow accumulating by raising the unit above the height of drifts normally experienced.

Baffles may be necessary to deflect strong winds and to prevent snow from blowing directly into the unit. They must not restrict air flow into the unit.

**CAUTION:** *Before lifting the unit, check that all casing panels are securely fixed in place. Lift and set down the unit with great care. Tilting and jarring can damage the unit and impair unit operation.*

The 30RA units can be hoisted with rigging. Coils should always be protected against crushing while a unit is being moved. Use struts or spreader bars to spread the slings above the unit. Do not tilt a unit more than 15°.

**WARNING:** *Never push or lever on any of the enclosure panels of the unit. Only the base of the unit frame is designed to withstand such stresses.*

## Checks before system start-up

Before the start-up of the refrigeration system, the complete installation, including the refrigeration system must be verified against the installation drawings, dimensional drawings, system piping and instrumentation diagrams and the wiring diagrams.

During the installation test national regulations must be followed. If no national regulation exists, paragraph 9-5 of standard EN 378-2 can be used as a guide.

External visual installation checks:

- Compare the complete installation with the refrigeration system and power circuit diagrams.
- Check that all components comply with the design specifications.
- Check that all safety documents and equipments that are required by current European standards are present.
- Verify that all safety and environmental protection devices and arrangements are in place and comply with the current European standard.
- Verify that all document for pressure containers, certificates, name plates, files, instruction manuals that are required documents required by the current European standards are present.
- Verify the free passage of access and safety routes.
- Check that ventilation in the plant room is adequate.
- Check that refrigerant detectors are present.
- Verify the instructions and directives to prevent the deliberate removal of refrigerant gases that are harmful to the environment.
- Verify the installation of connections.
- Verify the supports and fixing elements (materials, routing and connection).
- Verify the quality of welds and other joints.
- Check the protection against mechanical damage.
- Check the protection against heat.
- Check the protection of moving parts.
- Verify the accessibility for maintenance or repair and to check the piping.
- Verify the status of the valves.
- Verify the quality of the thermal insulation and of the vapour barriers.



### 3 - DIMENSIONS/CLEARANCES

#### 30RA 040-080

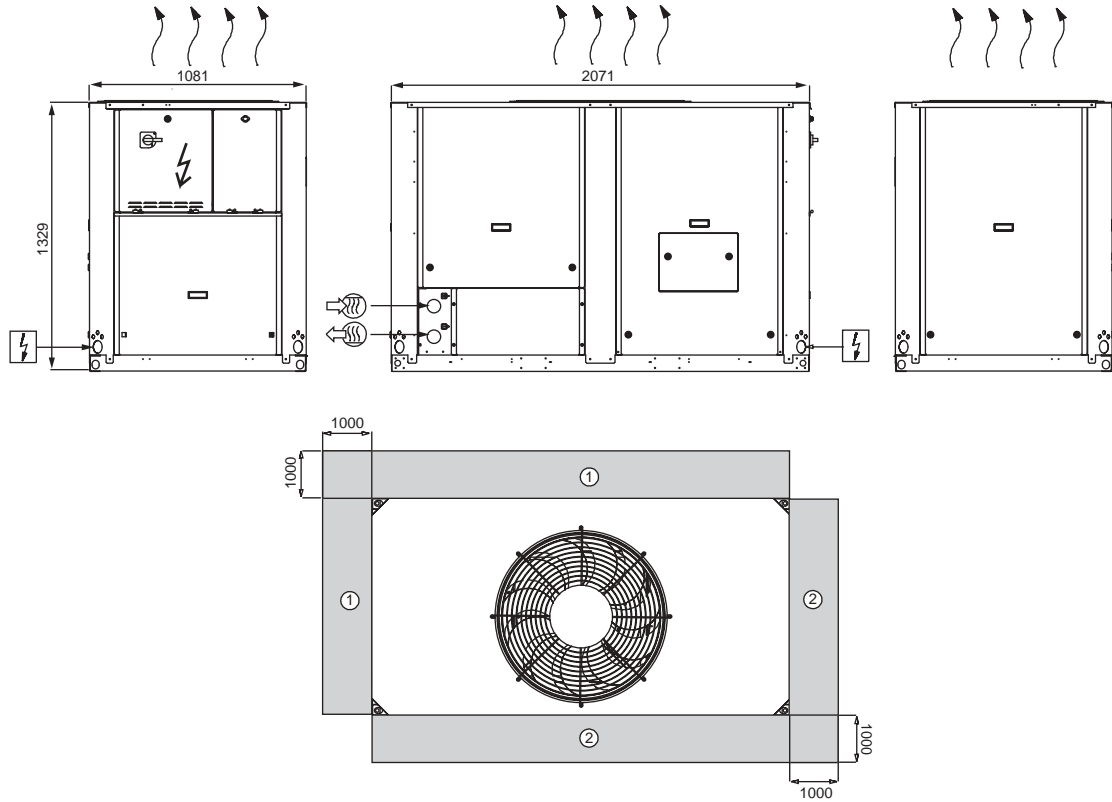



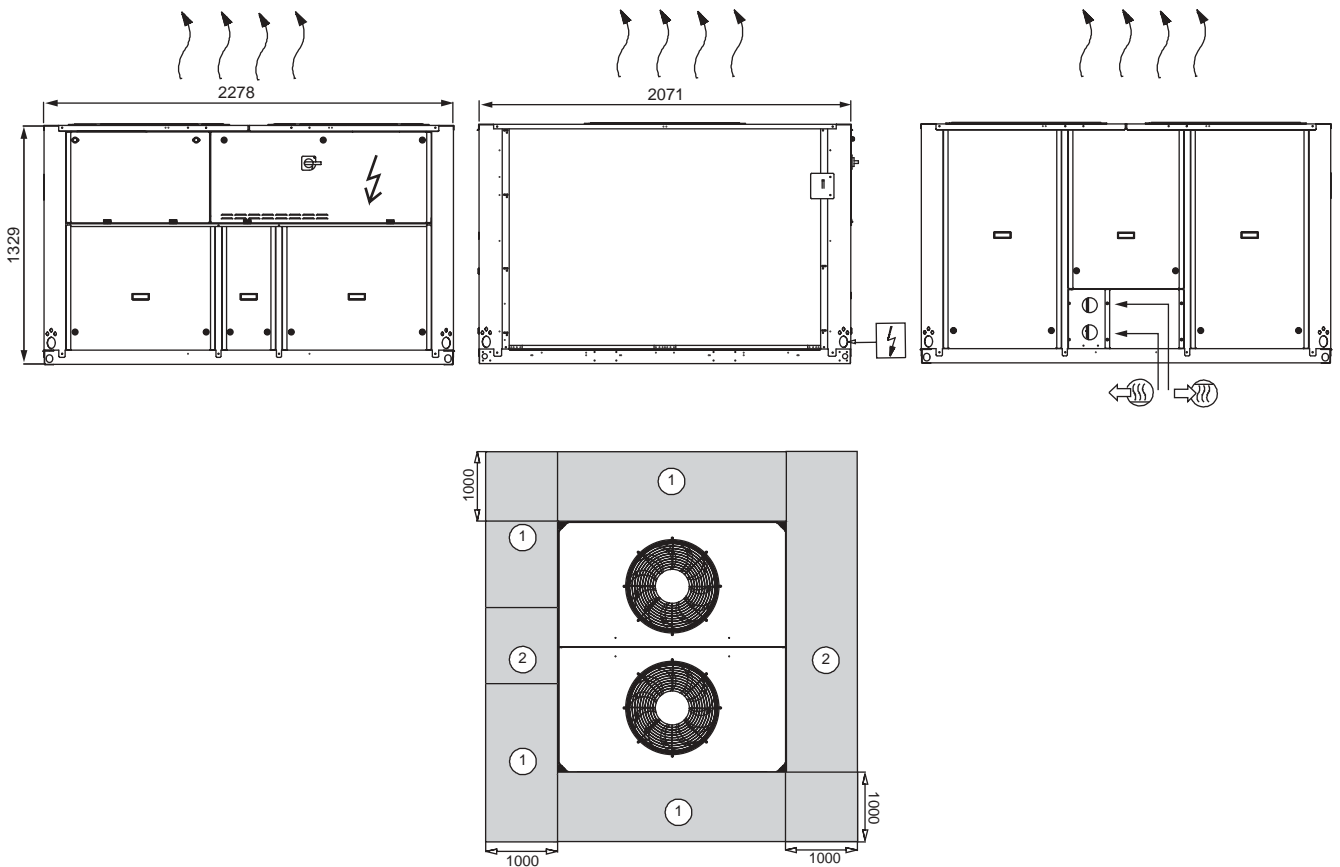

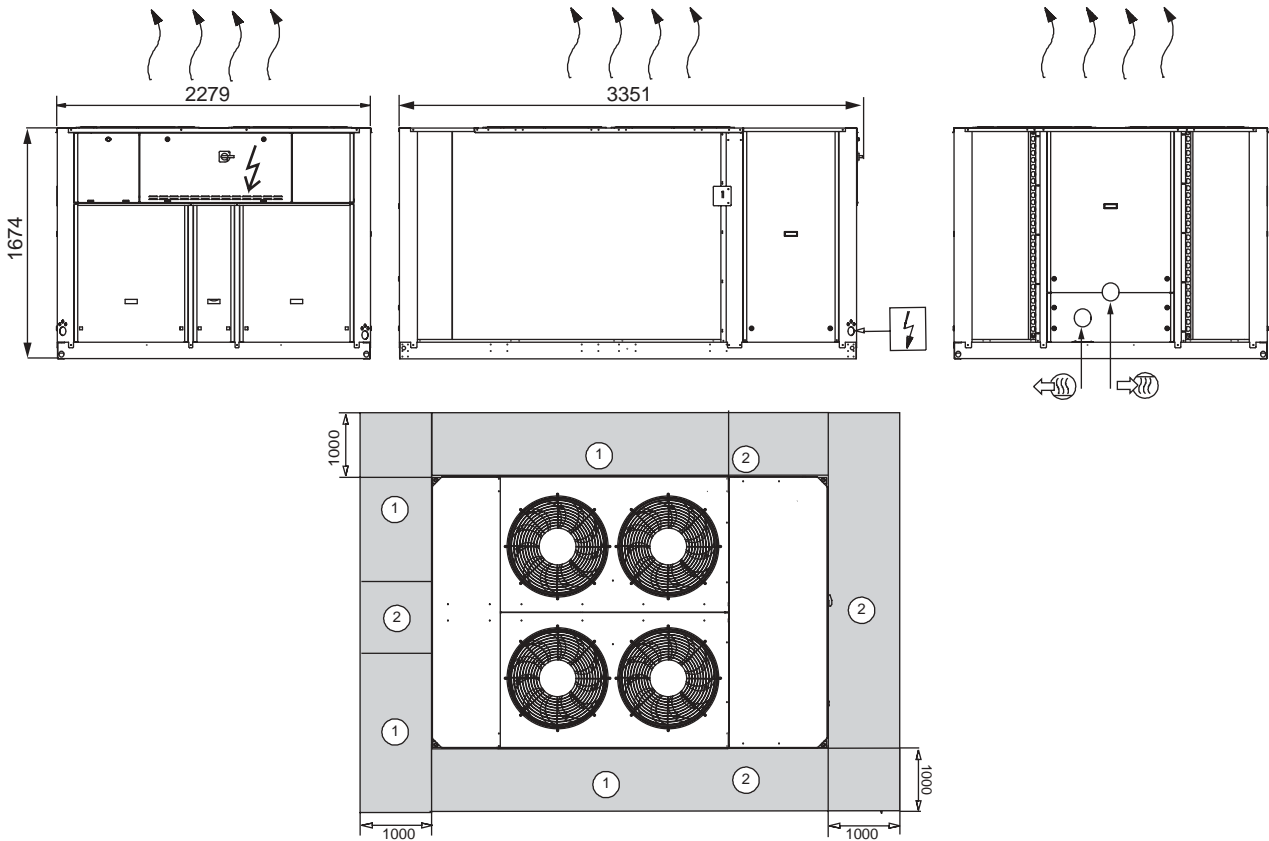

#### 30RA 090-160





**Legend:**  
All dimensions are given in mm

-  Control box
-  Water inlet
-  Water outlet
-  Required clearances for air flow
-  Recommended clearances for maintenance
-  Air outlet, do not obstruct
-  Power cable entry

**NOTE:**

- A Non-certified drawings.**  
Refer to the certified dimensional drawings supplied with the unit or available on request, when designing an installation.
- For the location of fixing points, weight distribution and coordinates of the centre of gravity refer to the certified dimensional drawings.**
- B In multiple-chiller installations (maximum four units), the side clearance between the units should be increased from 1000 to 2000 mm.**
- C The height of the solid surface must not exceed 2 m.**

**Multiple chiller installation**

**NOTE: If the walls are higher than 2 m, contact the factory.**

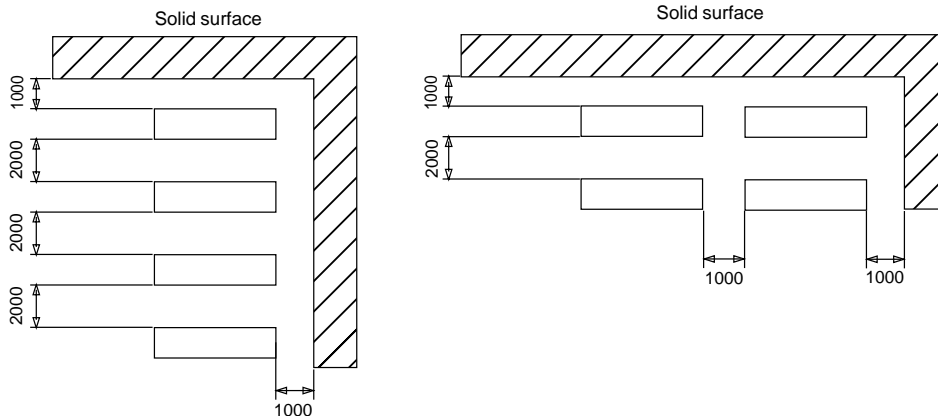

## 4 - PHYSICAL DATA

30RA		040	050	060	070	080	090	100	120	140	160	200	240
<b>Nominal cooling capacity*</b>	kW	39.4	49.0	57.0	67.0	79.0	89.0	97.0	115.0	135.0	157.0	202.0	245.0
<b>Operating weight with hydronic module</b>	kg												
Single pump		526	584	597	611	631	1093	1106	1205	1212	1248	2133	2305
Dual pump		606	664	677	691	708	1170	1183	1305	1312	1348	2221	2393
Operating weight without hydronic module		502	560	573	587	605	1062	1075	1167	1174	1210	1986	2158
<b>Refrigerant charge</b>	kg	R407C											
Circuit A		10	13	15	12.5	18	10	10	15	12.5	18	21	28
Circuit B		-	-	-	-	-	13	14	15	12.5	18	28	28
<b>Compressors</b>		Hermetic scroll compressor, 48.3 r/s											
Quantity, circuit A		1	2	2	2	2	1	1	2	2	2	2	3
Quantity, circuit B		-	-	-	-	-	2	2	2	2	2	3	3
No. of capacity steps		1	2	2	2	2	3	3	4	4	4	5	6
Minimum capacity	%	100	46	42	50	50	25	25	21	25	25	20	16.6
<b>Control type</b>		PRO-DIALOG Plus											
<b>Condensers</b>		Grooved copper tubes, aluminium fins											
<b>Fans</b>		Axial Flying Bird fans with rotating shroud											
Quantity		1	1	1	1	1	2	2	2	2	2	4	4
Total air flow (high speed)	l/s	3945	3780	4220	5150	5800	7725	8165	8840	10300	11600	17343	20908
Speed (high/low speed)	r/s	11.5/5.8	11.5/5.8	11.5/5.8	15.6/7.8	15.6/7.8	11.5/5.8	11.5/5.8	11.5/5.8	15.6/7.8	15.6/7.8	11.5/5.8	15.6/7.8
<b>Evaporator</b>		Direct-expansion welded plate heat exchanger											
Water volume	l	3.6	4.6	5.9	6.5	7.6	7.2	8.2	9.8	11.4	13.0	22.0	26.0
Max. water-side operating pressure	kPa												
Option without hydronic module		1000	1000	1000	1000	1000	1000	1000	1000	1000	1000	1000	1000
Unit with hydronic module		300	300	300	300	300	300	300	300	300	300	400	400
<b>Hydronic module</b>													
Pump (single centrifugal, 48.3 r/s)		Monocell composite pump											Monocell pump
Quantity		1	1	1	1	1	1	1	1	1	1	1	1
Expansion tank volume	l	12	12	12	12	12	35	35	35	35	35	50	50
Expansion tank pressure**	kPa	100	100	100	100	100	150	150	150	150	150	150	150
<b>Water connections</b>		Victaulic (connection sleeves supplied)											Threaded male gas connections
(with and without hydronic module)													
Diameter	in	2	2	2	2	2	2	2	2-1/2	2-1/2	2-1/2	3	3
Outside tube diameter	mm	60.3	60.3	60.3	60.3	60.3	60.3	60.3	76.1	76.1	76.1	88.9	88.9

\* Nominal conditions: evaporator entering/leaving water temperature 12°C/7°C, outdoor air temperature 35°C.

\*\* When delivered, the pre-inflation of the tank keeps the plated membrane in the upper part of the tank. To permit changing the water volume, change the inflation pressure to a pressure that is close to the static head of the system (see below), fill the system with water (purging the air) to a pressure value that is 10 to 20 kPa higher than the pressure in the tank.

Static head, m/Pressure, bar/Pressure, kPa

5 - 0,5 - 50 / 10 - 1 - 100 / 15 - 1,5 - 150 / 20 - 2 - 200 / 25 - 2,5 - 250

## 5 - ELECTRICAL DATA

30RA (without hydronic module)		040	050	060	070	080	090	100	120	140	160	200	240
<b>Power circuit</b>													
Nominal power supply	V-ph-Hz	400-3-50											
Voltage range	V	360-440											
<b>Control circuit supply</b>		The control circuit is supplied via the unit-mounted transformer											
<b>Maximum unit power input*</b>	kW	20.3	24.6	30.1	35.2	39.9	44.1	49.6	60.5	70.6	79.6	104.2	124.9
<b>Nominal unit current draw**</b>	A	27.9	34.7	41.1	47.0	54.3	62.7	69.1	82.3	94.1	108.6	140.2	168.7
<b>Maximum unit current draw at 360 V***</b>	A	36.9	45.6	54.9	62.7	72.4	82.6	91.9	109.8	125.4	144.8	185.4	222.9
<b>Maximum unit current draw at 400 V****</b>	A	33.6	41.4	49.7	56.9	65.6	75.1	83.4	99.5	113.9	131.3	168.6	202.8
<b>Maximum start-up current</b>													
Standard unit†	A	158.4	151.0	168.9	176.1	190.4	199.8	208.1	218.6	233.0	256.1	293.4	327.6
With electronic starter control‡	A	99.0	101	113	120	128	-	-	-	-	-	-	-

**Short-circuit stability and protection** See table on the next page

\* Power input of the compressor(s) + fan(s) at maximum unit operating conditions: entering/leaving water temperature = 15°C/10°C, maximum condensing temperature of 67.8°C, and 400 V nominal voltage (values given on the unit name plate).

\*\* Nominal unit current draw at nominal conditions: evaporator entering/leaving water temperature 12°C/7°C, outdoor air temperature 35°C. The current values are given at 400 V nominal voltage.

\*\*\* Maximum unit operating current at maximum unit power input and 360 V.

\*\*\*\* Maximum unit operating current at maximum unit power input and 400 V (values given on the unit name plate).

† Maximum instantaneous starting current at 400 V nominal voltage and with compressor in across-the-line start (maximum operating current of the smallest compressors + fan current + locked rotor current of the largest compressor).

‡ Maximum instantaneous starting current at 400 V nominal voltage and with compressor with electronic starter (maximum operating current of the smallest compressor(s) + fan current + reduced start-up current of the largest compressor).

Hydronic module		040	050	060	070	080	090	100	120	140	160	200	240
<b>Single pump</b>													
Shaft power	kW	0.75	0.75	0.75	0.75	1.1	1.1	1.1	1.85	1.85	1.85	5.5	5.5
Power input*	kW	1.1	1.1	1.1	1.1	1.4	1.4	1.4	2.5	2.5	2.5	6.6	6.6
Maximum current draw at 400 V**	A	2.1	2.1	2.1	2.1	3.1	3.1	3.1	5.0	5.0	5.0	10.9	10.9
<b>Dual pump</b>													
Shaft power	kW	2.2	2.2	2.2	2.2	2.2	2.2	2.2	3.0	3.0	3.0	5.5	5.5
Power input*	kW	2.7	2.7	2.7	2.7	2.7	2.7	2.7	4.0	4.0	4.0	6.6	6.6
Maximum current draw at 400 V**	A	4.7	4.7	4.7	4.7	4.7	4.7	4.7	6.6	6.6	6.6	10.9	10.9

**Note:** The water pump power input values are given for guidance only.

\* To obtain the maximum power input for a unit with hydronic module add the maximum unit power input from the top table to the pump power input (\*) from the table above.

\*\* To obtain the maximum unit operating current draw for a unit with hydronic module add the maximum unit current draw from the top table to the pump current draw from the table above.

## Compressor usage and electrical data

Reference code	COMPRESSOR				30RA											
	I Nom	I Max	LRA*	Circuit	040	050	060	070	080	090	100	120	140	160	200	240
DQ 12 CA 001EE	14.0	19.1	130	A B		A1										
DQ 12 CA 002EE	16.2	22.1	130	A B		A2	A1						A1 B1			
DQ 12 CA 031EE	21.9	28.3	145	A B			A2	A1+A2					A2 B2	A1+A2 B1+B2		
DQ 12 CA 036EE	24.5	32.8	155	A B	A1				A1+A2	A1	A1			A1+A2 B1+B2	A1+A2 B1+B2+B3	A1+A2+A3 B1+B2+B3

### Legend:

I Nom Nominal current draw at Eurovent conditions (see definition of conditions under nominal unit current draw), A

I Max Maximum operating current at 360 V, A

LRA Locked rotor current, A

\* With option 25 (electronic starter) the LRA value is reduced by 40%; the maximum start-up time per compressor is <0.8 seconds.

## Short-circuit stability and protection

30RA	Short-term short-circuit stability (1s) Without fuse rms value/peak kA*	With fuse rms value kA **	Other fuses rms value kA***	Other protection type I <sup>2</sup> t (A <sup>2</sup> s)/peak limit kA****
040-080	5/7.5	80A gL:50	100A gL:30 125A gL:25 160A gL:6	19200/12
090-160	8/15	160A gL:100	200A gL:35	155000/20
200	8/15	200A gL:100	224A gL:40 250A gL:35	280000/20
240	8/15	250A gL:50	N/A	550000/25

\* This value corresponds to the switch/disconnect capacity, to the power distribution bus bar system capacity (if used) and to the protection circuit capacity in the standard unit.

\*\* If the short-circuit current is higher, the unit can be protected by the fuse shown for the specific level.

The fuses (not supplied for Carrier units) are as recommended, to be installed upstream of the unit.

For unit sizes 040 to 160 a fused disconnect switch, equipped with fuses, can be installed in place of the standard unit switch. This should be done on site; please contact the local service department or a qualified electrician. Alternatively please order the special version from the factory by contacting your local Carrier dealer.

For unit sizes 200 and 240 the installation requires drilling a hole into the control box, changing of the front door, and adapting the bus bar to be able to install the new fused disconnect switch which is larger than the one used for the standard units. To order this special version from the factory, contact your local Carrier office.

List of recommended components with Siemens reference details:

30RA	Fused disconnect	Contact protection	Control handle	NH Fuses	New protection level with fused disconnect switch, rms value, kA**
040-080	80 A: 3KL7114-3AA00	3KX71-32-1AA00	Use from disconnect switch of the standard unit	80 A 00gL: 3NA3 824 (3 off)	100
090-160	160 A: 3KL7123-3DA00	3KX71-32-2AA00		160 A 00gL: 3NA3 836 (3 off)	50
200-240	200 A: 3KL7131-3AA00	3KX71-32-3AA00 + 3KX71-31-3AA00 + 3KX71-31-3AB00	3KX7112-4AA00	200 A 1gL: 3NA3 140 (3 off) 224 A 1gL: 3NA3 142 (3 off) 250 A 1gL: 3NA3 144 (3 off)	200 A gL: 50 224 A gL: 50 250 A gL: 50
	224 A + 250 A: 3KL7132-3AA00				
240	315 A: 3KL7141-3AA00 400 A: 3KL7142-3AA00	3KX71-32-4AA00 + 3KX71-31-4AA00 + 3KX71-31-4AB00	3KX7112-4AA00	315 A 2gL: 3NA3 252 (3 off) 400 A 2gL: 3NA3 260 (3 off)	315 A gL: 40 400 A gL: 30

\*\*\* Shows the new protection values with higher-capacity fuses than those specified in the previous column. If such fuses are part of the electrical installation upstream of the unit, this is sufficient as anti-short circuit protection to the specified level, without additional protection.

\*\*\*\* If a protection device, other than the recommended fuses above, is used for the installation to ensure that no additional protection is required, the protection device must have the specified thermal limit (I<sup>2</sup>t) and limit effect characteristics for the short-circuit current. If the protection device does not have the specified characteristics, one of the specified protection fuses from the previous columns must be installed.

## Electrical data notes 30RA:

- 30RA 040-240 units have a single power connection point located at the main switch.
- The control box includes the following standard features:
  - a main disconnect switch, starter and motor protection devices for each compressor, the fan and the pump
  - the control devices
- **Field connections:**  
All connections to the system and the electrical installations must be in full accordance with all applicable local codes.
- The Carrier 30RA units are designed and built to ensure conformance with these codes. The recommendations of European standard EN 60204-1 (machine safety - electrical machine components - part 1: general regulations - corresponds to IEC 60204-1) are specifically taken into account, when designing the electrical equipment.

### NOTES:

- Generally the recommendations of IEC 60364 are accepted as compliance with the requirements of the installation directives. Conformance with EN 60204 is the best means of ensuring compliance with the Machines Directive § 1.5.1.
  - Annex B of EN 60204-1 describes the electrical characteristics used for the operation of the machines.
1. The operating environment for the 30RA units is specified below:
    - a. Environment\* - Environment as classified in EN 60721 (corresponds to IEC 60721):
      - outdoor installation\*
      - ambient temperature range: -10°C to +45°C, class 4K3\*

- altitude:  $\leq 2000$  m
  - presence of hard solids, class 4S2 (no significant dust present)
  - presence of corrosive and polluting substances, class 4C2 (negligible)
  - vibration and shock, class 4M2
- b. Competence of personnel, class BA4\* (trained personnel - IEC 60364)
2. Power supply frequency variation:  $\pm 2$  Hz.
  3. The neutral (N) conductor must not be connected directly to the unit (if necessary use a transformer).
  4. Overcurrent protection of the power supply conductors is not provided with the unit.
  5. The factory-installed disconnect switch(es)/circuit breaker(s) is (are) of a type suitable for power interruption in accordance with EN 60947.
  6. The units are designed for connection to TN networks (IEC 60364). For IT networks the earth connection must not be at the network earth. Provide a local earth, consult competent local organisations to complete the electrical installation.

**Caution: If particular aspects of an actual installation do not conform to the conditions described above, or if there are other conditions which should be considered, always contact your local Carrier representative.**

- \* The required protection level for this class is IP43BW (according to reference document IEC 60529). All 30RA units are protected to IP44CW and fulfil this protection condition.

## 6 - APPLICATION DATA

### 6.1 - Unit operating range

Evaporator	Minimum °C	Maximum °C
Water entering temp. (at start-up)	7.8 *	30
Water leaving temp. (in operation)	5 **	15
Water entering temp. (at shut down)	-	55
Condenser		
Entering air temp.	-10***	46***

- Do not exceed the maximum operating temperature.  
 \* For a system requiring operation below 7,8°C, contact Carrier SA.  
 \*\* For a system requiring operation below 5°C, anti-freeze must be added to the unit.  
 \*\*\* Maximum outside temperature: For transport and storage of the 30RA units the minimum and maximum allowable temperatures are -20°C and +55°C. It is recommended that these temperatures are used for transport by container.

### 6.2 - Evaporator water flow rates

30RA	Evaporator water flow			
	Min. flow rate l/s	Max. flow rate* Single pump l/s	Dual pump l/s	Max. flow rate** l/s
040	1.1	3.5	4.4	3.7
050	1.1	4	5.2	4.6
060	1.4	4.4	6	5.8
070	1.5	4.6	6.4	6.4
080	1.7	5.5	6.8	7.3
090	2.7	5.6	6.9	7.6
100	3	5.8	7.4	8.8
120	3.6	8.5	10.5	10.8
140	4.2	8.8	11.4	12.7
160	4.8	9.1	11.9	14.4
200	5.6	15.3	15.3	19.1
240	6.8	23.4	23.4	24.2

- Legend**  
 \* Maximum flow rate at an available pressure of 50 kPa (unit with hydronic module).  
 \*\* Maximum flow rate at a pressure drop of 100 kPa in the plate heat exchanger (unit without hydronic module).

### 6.3 - Minimum water flow rate

If the installation flow rate is below the minimum flow rate, recirculation of the evaporator water flow may take place, leading to the risk of excessive fouling.

### 6.4 - Maximum evaporator water flow rate

This is limited by the permitted evaporator pressure drop. Also, a minimum evaporator  $\Delta T$  of 2.8 K must be guaranteed, which corresponds to a water flow rate of 0.9 l/s per kW.

### 6.5 - Water loop volume

#### 6.5.1 - Minimum water loop volume

The minimum water loop volume, in litres, is given by the following formula:  
 Volume = CAP (kW) x N\* = litres, where CAP is the nominal cooling capacity at nominal operating conditions.

Application	N*
<b>Air conditioning</b>	
30RA 040	3.5
30RA 050 to 240	2.5
<b>Industrial process cooling</b>	
30RA 040 to 240	(See note)

**NOTE: For industrial process cooling applications, where high stability of the water temperature levels must be achieved, the values above must be increased.**

This volume is required to obtain temperature stability and precision.

To achieve this volume, it may be necessary to add a storage tank to the circuit. This tank should be equipped with baffles to allow mixing of the fluid (water or brine). Please refer to the examples below.

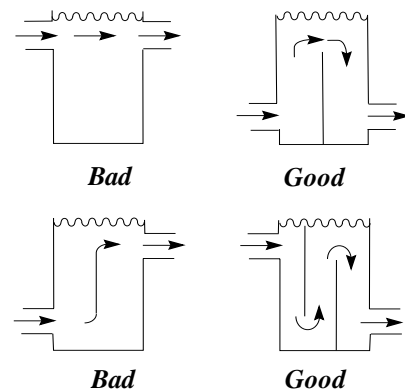

#### 6.5.2 - Maximum water loop volume

Units with hydronic module incorporate an expansion tank that limits the water loop volume. The table below gives the maximum loop volume for pure water or ethylene glycol with various concentrations.

	30RA 040-080 (in litres)	30RA 090-160 (in litres)	30RA 200-240 (in litres)
<b>Pure water</b>	600	1500	2000
<b>EG 10%</b>	450	1200	1600
<b>EG 20%</b>	400	1000	1400
<b>EG 35%</b>	300	800	1000

EG: Ethylene glycol

## 6.6 - Unit operating range at full and part load

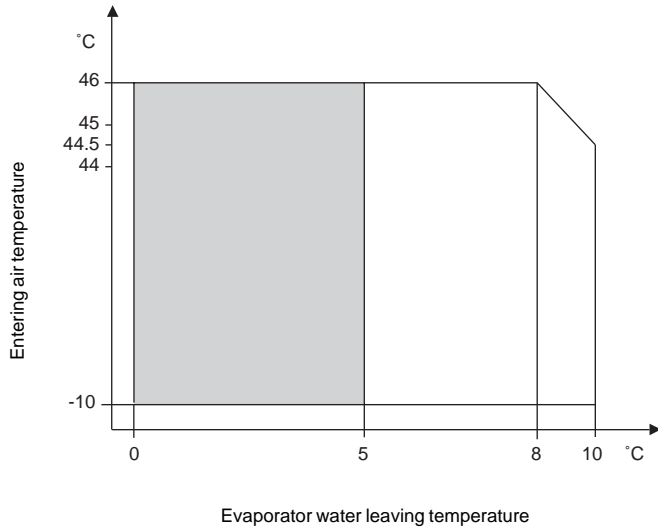

- 1 Evaporator  $\Delta T = 5 \text{ K}$
- 2 The evaporator and the hydronic circuit pump are frost protected down to  $-10^\circ\text{C}$  outside air temperature.

Operating range with required anti-freeze solution and special Pro-Dialog control configuration

## 6.7 - Pressure drop in the plate heat exchangers

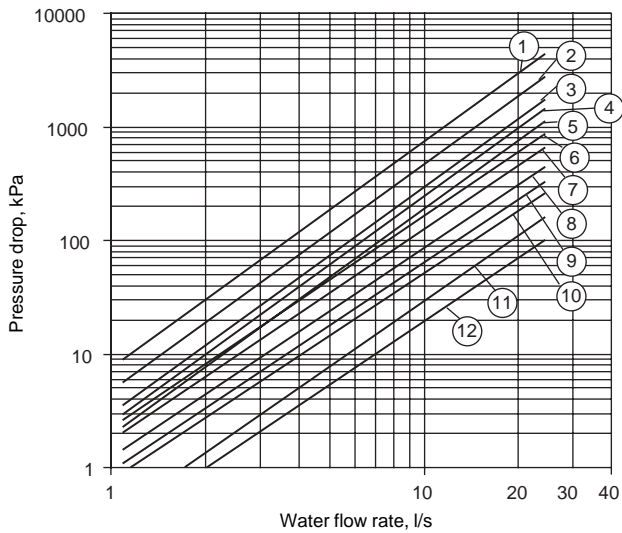

### Legend

- 1 30 RA 040
- 2 30 RA 050
- 3 30 RA 060
- 4 30 RA 070
- 5 30 RA 080
- 6 30 RA 090
- 7 30 RA 100
- 8 30 RA 120
- 9 30 RA 140
- 10 30 RA 160
- 11 30 RA 200
- 12 30 RA 240

## 7 - ELECTRICAL CONNECTION

### 7.1 - Control box

#### 30RA 040-080

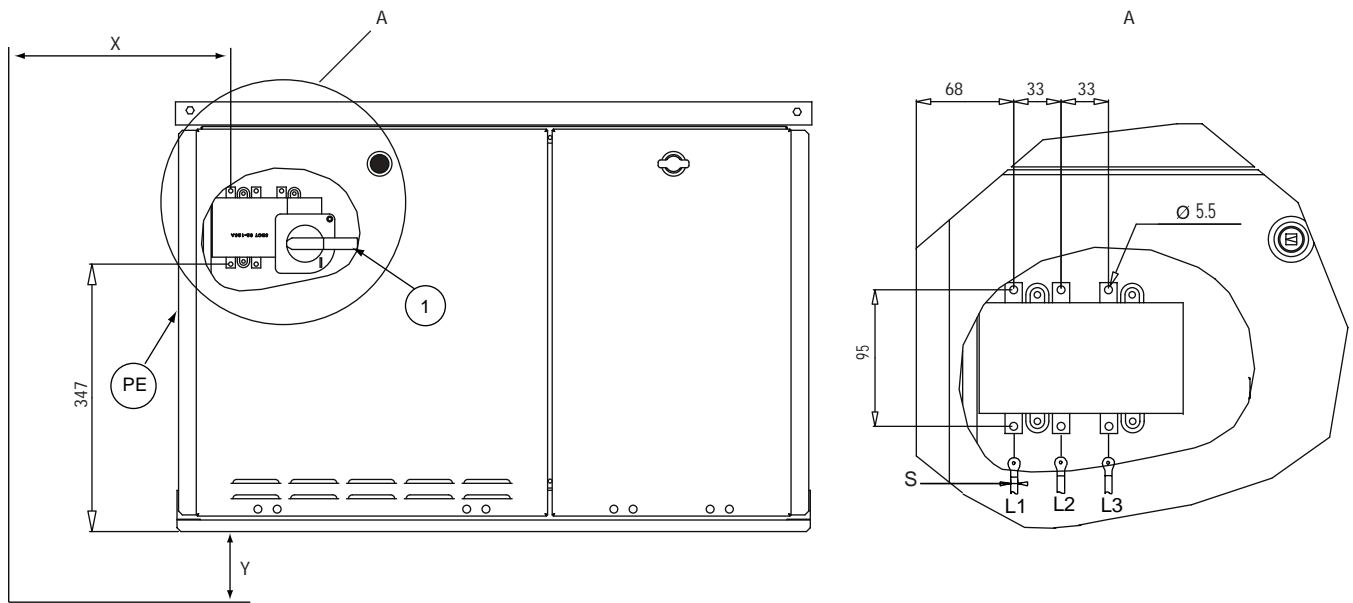

#### 30RA 090-160

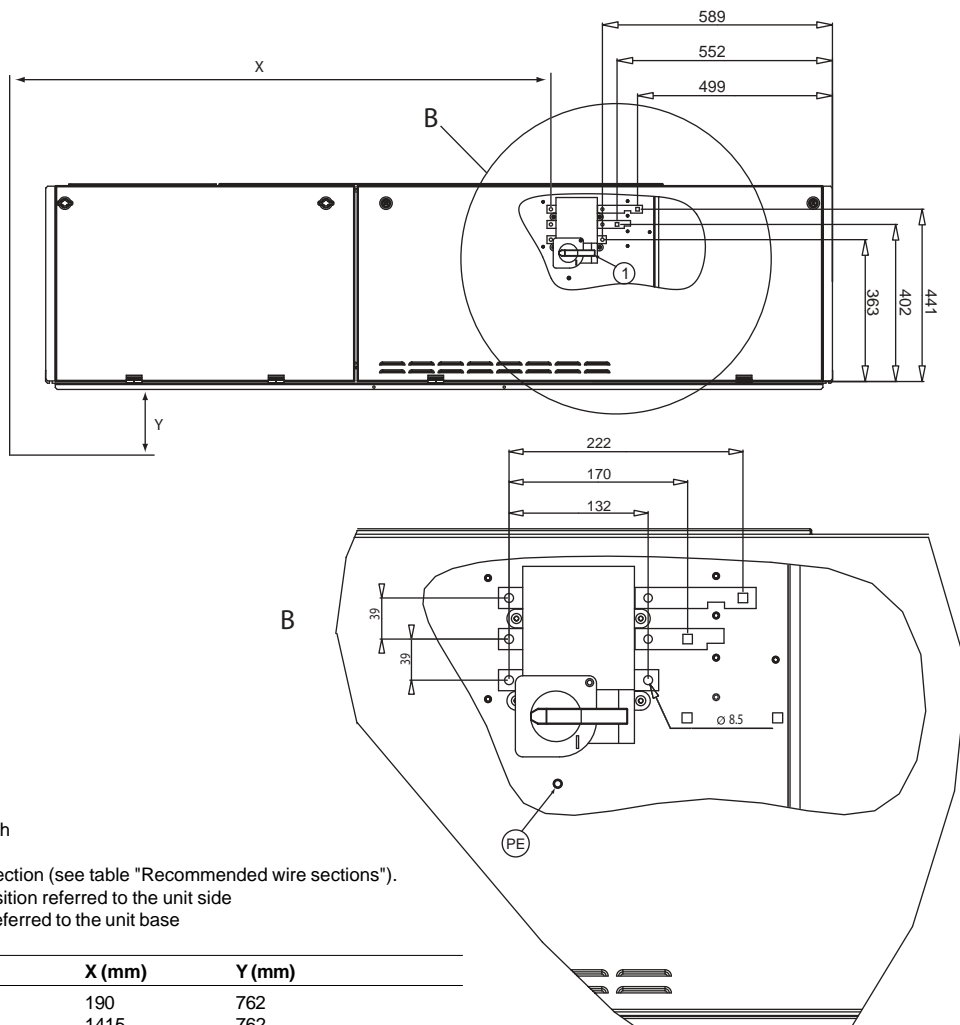

#### Legend

- 1 Main disconnect switch
- PE Earth connection
- S Power supply cable section (see table "Recommended wire sections").
- X Disconnect switch position referred to the unit side
- Y Control box position referred to the unit base

	X (mm)	Y (mm)
30RA 040 - 080	190	762
30RA 090 - 160	1415	762
30RA 200 - 240	1161	1107



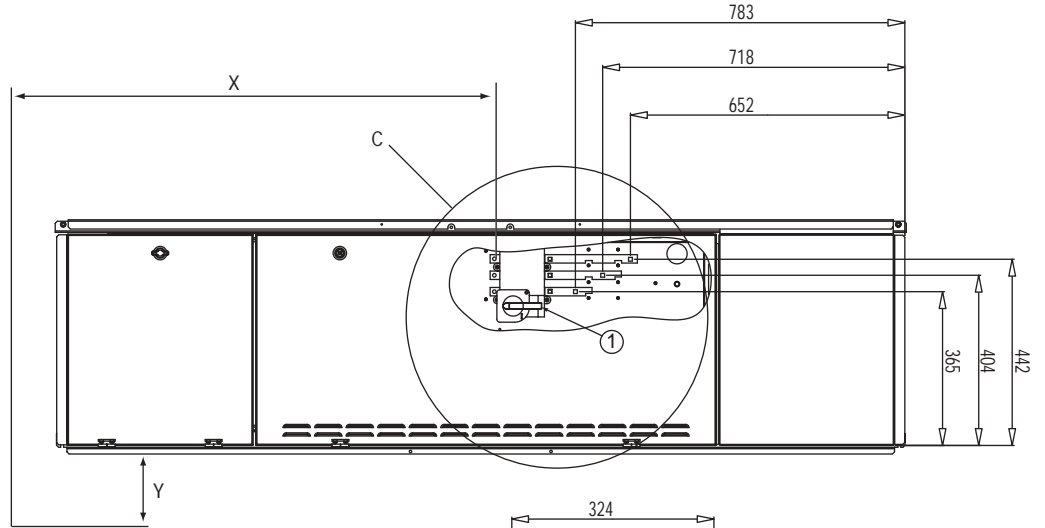

**Legend**

- 1 Main disconnect switch
- PE Earth connection
- S Power supply cable section (see table "Recommended wire sections").
- X Disconnect switch position referred to the unit side
- Y Control box position referred to the unit base

	X (mm)	Y (mm)
30RA 040 - 080	190	762
30RA 090 - 160	1415	762
30RA 200 - 240	1161	1107

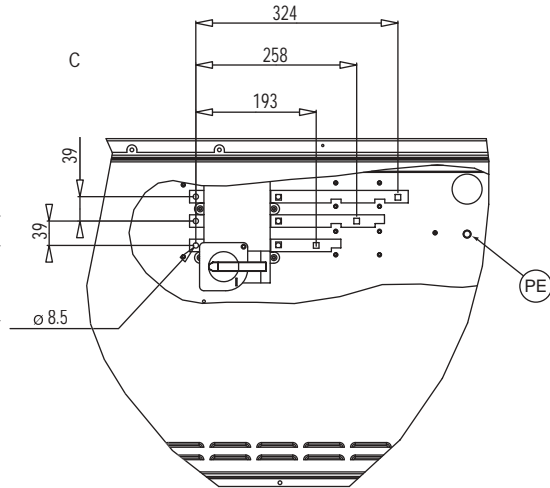

**NOTES:**

The 30RA 040-240 units have only one power connection point located at the main disconnect switch.

Before connecting electric power cables, it is imperative to check the correct order of the 3 phases (L1 - L2 - L3).

Non-certified drawings. Refer to the certified drawings supplied with the unit or available on request.

**7.2 - Power supply**

The power supply must conform to the specification on the chiller name plate. The supply voltage must be within the range specified in the electrical data table.

For connections refer to the wiring diagrams.

**WARNING: Operation of the chiller with an improper supply voltage or excessive phase imbalance constitutes abuse which will invalidate the Carrier warranty. If the phase imbalance exceeds 2% for voltage, or 10% for current, contact your local electricity supply source at once and ensure that the chiller is not switched on until corrective measures have been taken.**

**7.3 - Voltage phase imbalance (%)**

$$\frac{100 \times \text{max. deviation from average voltage}}{\text{Average voltage}}$$

**Example:**

On a 400 V - 3 ph - 50 Hz supply, the individual phase voltages were measured to be:

AB = 406 V ; BC = 399 ; AC = 394 V

Average voltage = (406 + 399 + 394)/3 = 1199/3 = 399.7 say 400 V

Calculate the maximum deviation from the 400 V average:

(AB) = 406 - 400 = 6  
 (BC) = 400 - 399 = 1  
 (CA) = 400 - 394 = 6

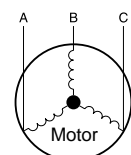

The maximum deviation from the average is 6 V. The greatest percentage deviation is: 100 x 6/400 = 1.5 %

This is less than the permissible 2% and is therefore acceptable.

## 8 - RECOMMENDED WIRE SECTIONS

Wire sizing is the responsibility of the installer, and depends on the characteristics and regulations applicable to each installation site. The following is only to be used as a guideline, and does not make Carrier in any way liable. After wire sizing has been completed, using the certified dimensional drawing, the installer must ensure easy connection and define any modifications necessary on site. The connections provided as standard for the field-supplied power entry cables to the general disconnect/isolator switch are designed for the number and type of wires, listed in the table below.

The calculations are based on the maximum machine current (see electrical data tables) and the standard installation practises, in accordance with IEC 60364, table 52C.

- For 30RA units, installed outside, the following standard installation practises have been maintained:

No.17: suspended aerial lines, and No. 61: buried conduit with a derating coefficient of 20.

The calculation is based on PVC or XLPE insulated cables with copper core.

A maximum ambient temperature of 46°C has been taken into consideration.

The given wire length limits the voltage drop to < 5% (length L in metres - see table below).

**IMPORTANT: Before connection of the main power cables (L1 - L2 - L3) on the terminal block, it is imperative to check the correct order of the 3 phases before proceeding to the connection on the main disconnect/isolator switch.**

## 8.1 - Field control wiring

For the field control wiring of the following elements please refer to the 30RA/RH - RY/RYPH "B" series Pro-Dialog Plus Control manual, and the certified wiring diagram supplied with the unit:

- Unit start/stop
- Heating/cooling selection
- Set-point selection
- Customer interlock - (example: auxiliary contact of the chilled water pump contactor)
- General alarm reporting, circuit A and circuit B

Unit	S Min. (mm <sup>2</sup> ) by phase	Cable type	L (m)	S Max. (mm <sup>2</sup> ) by phase	Cable type	L (m)
30RA 040	1x 6	XLPE Cu	90	1x 16	PVC Cu	245
30RA 050	1x 6	XLPE Cu	80	1x 25	PVC Cu	300
30RA 060	1x 10	XLPE Cu	110	1x 25	PVC Cu	300
30RA 070	1x 10	XLPE Cu	100	1x 35	PVC Cu	310
30RA 080	1x 16	XLPE Cu	125	1x 50	PVC Cu	350
30RA 090	1x 16	XLPE Cu	115	1x 70	PVC Cu	380
30RA 100	1x 25	XLPE Cu	145	1x 70	PVC Cu	380
30RA 120	1x 25	XLPE Cu	135	1x 95	PVC Cu	410
30RA 140	1x 35	XLPE Cu	150	1x 120	PVC Cu	435
30RA 160	1x 50	XLPE Cu	180	1x 120	XLPE Cu	400
30RA 200	1x 70	XLPE Cu	180	1x 150	XLPE Cu	335
30RA 240	1x 70	XLPE Cu	180	1x 185	XLPE Cu	345

S Power supply cable section (see the diagram in chapter: "Electrical connection")

## 9 - WATER CONNECTIONS

For size and position of the unit water inlet and outlet connections refer to the certified dimensional drawings supplied with the unit. The water pipes must not transmit any radial or axial force to the heat exchangers nor any vibration.

The water supply must be analysed and appropriate filtering, treatment, control devices, shutoff and bleed valves and circuits built in, to prevent corrosion (example: damage to the protection of the tube surface if the fluid is polluted), fouling and deterioration of the pump fittings.

Before any start-up verify that the heat exchange fluid is compatible with the materials and the water circuit coating.

In case additives or other fluids than those recommended by Carrier s.a are used, ensure that the fluids are not considered as a gas, and that they belong to class 2, as defined in directive 97/23/EC.

### Carrier s.a. recommendations on heat exchange fluids:

1. No  $\text{NH}_4^+$  ammonium ions in the water, they are very detrimental for copper. This is one of the most important factors for the operating life of copper piping. A content of several tenths of mg/l will badly corrode the copper over time.
2.  $\text{Cl}^-$  Chloride ions are detrimental for copper with a risk of perforations by corrosion by puncture. If possible keep below 10 mg/l.
3.  $\text{SO}_4^{2-}$  sulphate ions can cause perforating corrosion, if their content is above 30 mg/l.
4. No fluoride ions (<0.1 mg/l).
5. No  $\text{Fe}^{2+}$  and  $\text{Fe}^{3+}$  ions with non negligible levels of dissolved oxygen must be present. Dissolved iron < 5 mg/l with dissolved oxygen < 5 mg/l.
6. Dissolved silicon: silicon is an acid element of water and can also lead to corrosion risks. Content < 1mg/l.
7. Water hardness: TH >2.8 K. Values between 10 and 25 can be recommended. This will facilitate scale deposit that can limit corrosion of copper. TH values that are too high can cause piping blockage over time. A total alkalimetric titre (TAC) below 100 is desirable.
8. Dissolved oxygen: Any sudden change in water oxygenation conditions must be avoided. It is as detrimental to deoxygenate the water by mixing it with inert gas as it is to over-oxygenate it by mixing it with pure oxygen. The disturbance of the oxygenation conditions encourages destabilisation of copper hydroxides and enlargement of particles.
9. Specific resistance – electric conductivity: the higher the specific resistance, the slower the corrosion tendency. Values above 3000 Ohm/cm are desirable. A neutral environment favours maximum specific resistance values. For electric conductivity values in the order of 200-6000 S/cm can be recommended.
10. pH: Ideal case pH neutral at 20-25°C ( $7 < \text{pH} < 8$ ).

**ATTENTION:** Charging, adding or draining fluid from the water circuit must be done by qualified personnel, using air vents and materials suitable for the products. The water circuit charging devices are field-supplied.

**Charging and removing heat exchange fluids should be done with devices that must be included on the water circuit by the installer. Never use the unit heat exchangers to add heat exchange fluid.**

### 9.1 - Operating precautions and recommendations

The water circuit should be designed to have the least number of elbows and horizontal pipe runs at different levels. Below the main points to be checked for the connection:

- Comply with the water inlet and outlet connections shown on the unit.
- Install manual or automatic air purge valves at all high points in the circuit.
- Use an expansion device to maintain pressure in the system and install a safety valve as well as an expansion tank. Units with a hydronic module include the safety valve and the expansion tank.
- Install thermometers in both the entering and leaving water connections.
- Install drain connections at all low points to allow the whole circuit to be drained.
- Install stop valves, close to the entering and leaving water connections.
- Use flexible connections to reduce the transmission of vibrations.
- Insulate all pipework, after testing for leaks, both to reduce thermal leaks and to prevent condensation.
- If the external unit water pipes are in an area, where the ambient temperature is likely to fall below 0°C, insulate the piping and add an electric heater. The internal unit piping is protected down to -20°C.

**NOTE:** For units not equipped with a hydronic module a screen filter must be installed as close to the heat exchanger as possible, in a position that is easily accessible for removal and cleaning. Units with hydronic module are equipped with this type of filter.

**The mesh size of the filter must be 1.2 mm.**

**The plate heat exchanger can foul up quickly at the initial unit start-up, as it complements the filter function, and the unit operation will be impaired (reduced water flow rate due to increased pressure drop).**

**Before the system start-up verify that the water circuits are connected to the appropriate heat exchangers (e.g. no reversal between evaporator and condenser).**

**Do not introduce any significant static or dynamic pressure into the heat exchange circuit (with regard to the design operating pressures).**

**The products that may be added for thermal insulation of the containers during the water piping connection procedure must be chemically neutral in relation to the materials and coatings to which they are applied. This is also the case for the products originally supplied by Carrier s.a.**

## 9.2 - Hydronic connections

The diagram on the next page shows a typical hydronic installation.

When charging the water circuit use air vents to evacuate any residual air pockets.

## 9.3 - Frost protection

The plate heat exchangers, the piping and the hydronic module pump can be damaged by frost, despite the built-in anti-freeze protection of the units.

The frost protection of plate heat exchanger and all hydronic module components is guaranteed down to  $-20^{\circ}\text{C}$  by automatically energized heaters and pump cycling.

Never switch off the evaporator and hydronic circuit heaters or the pump, otherwise frost protection cannot be guaranteed.

For this reason the main unit disconnect switch (QS101) as well as the auxiliary protection switch (QF101) for the heaters must always be left closed (for location of QS and QF 101 see wiring diagram).

To ensure frost protection down to  $-20^{\circ}\text{C}$ , water circulation in the water circuit must be maintained by periodically switching on the pump. If a shut-off valve is installed, a bypass must be included as shown below.

**Winter position**

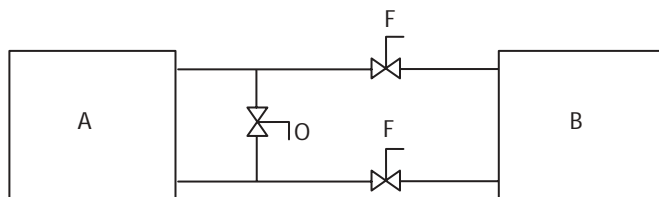

### Legend

- A Unit
- B Water network
- C Closed
- O Open

### **IMPORTANT:**

*Depending on the atmospheric conditions in your area you must do the following when switching the unit off in winter:*

- *Add ethylene glycol with an adequate concentration to protect the installation up to a temperature of 10 K below the lowest temperature likely to occur at the installation site.*
- *If the unit is not used for an extended period, it is recommended to drain it, and as a safety precaution introduce ethylene glycol in the heat exchanger, using the water entering purge valve connection.  
At the start of the next season, refill the unit with water and add an inhibitor.*
- *For the installation of auxiliary equipment, the installer must comply with basic regulations, especially for minimum and maximum flow rates, which must be between the values listed in the operating limit table (application data).*
- *To prevent corrosion by differential aeration, the complete drained heat transfer circuit must be charged with nitrogen for a period of one month. If the heat transfer fluid does not comply with the Carrier S.A. regulations, the nitrogen charge must be added immediately.*

## Typical hydronic circuit diagram

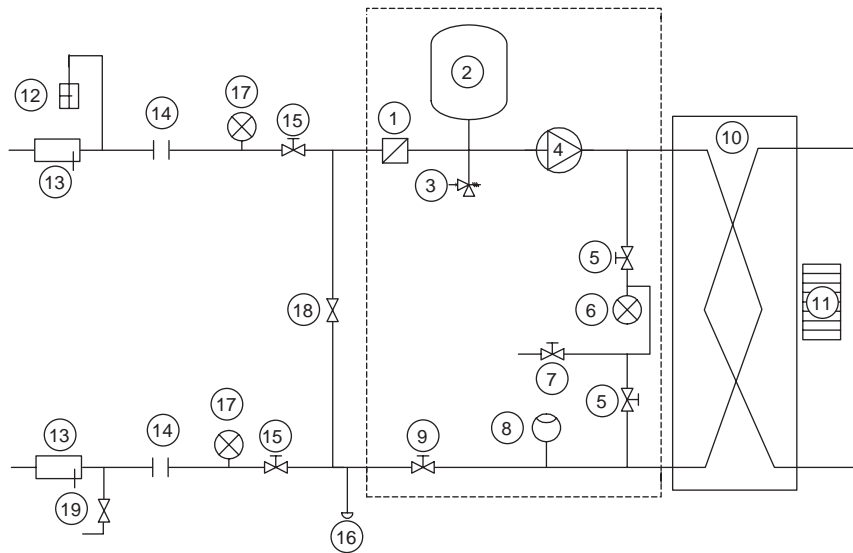

### Legend

#### Components of the unit and hydronic module

- 1 Victaulic screen filter
- 2 Expansion tank
- 3 Safety valve
- 4 Available pressure pump
- 5 Purge valve and pressure tap
- 6 Pressure gauge to measure the plate heat exchanger pressure drop (to be isolated with valve No. 5 if not used)
- 7 System air vent
- 8 Flow switch
- 9 Flow control valve
- 10 Plate heat exchanger
- 11 Evaporator defrost heater

#### Installation components

- 12 Air vent
  - 13 Thermometer sleeve
  - 14 Flexible connection
  - 15 Check valve
  - 16 System water drain plug (on connection pipe supplied in the unit)
  - 17 Pressure gauge
  - 18 Freeze-up protection bypass valve (when valve No. 15 are closed during winter)
  - 19 Charge valve
- Hydronic module (unit with hydronic module)

#### Note:

Units without hydronic module (option) are equipped with a flow switch and an internal piping heater.

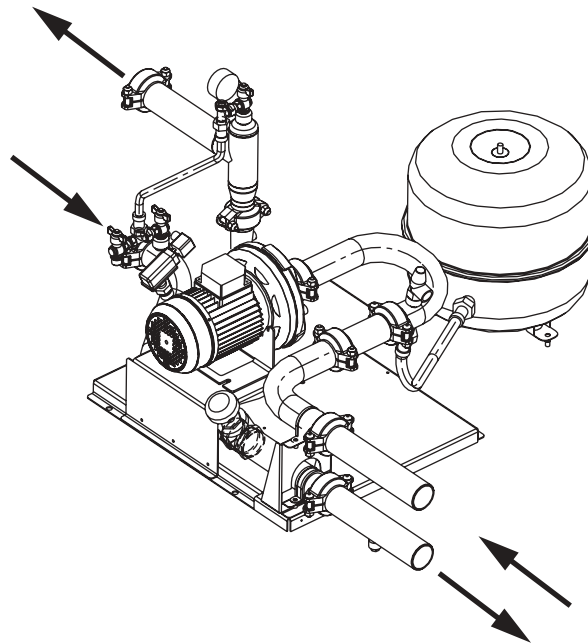

Hydronic module

## 10 - NOMINAL SYSTEM WATER FLOW CONTROL

The water circulation pumps of the 30RA units have been sized to allow the hydronic modules to cover all possible configurations based on the specific installation conditions, i.e. for various temperature differences between the entering and the leaving water ( $\Delta T$ ) at full load, which can vary between 3 and 10°C.

This required difference between the entering and leaving water temperature determines the nominal system flow rate. It is above all absolutely necessary to know the nominal system flow rate to allow its control via a manual valve provided in the water leaving piping of the module (item 9 in the typical hydronic circuit diagram).

With the pressure loss generated by the control valve in the hydronic system, the valve is able to impose the system pressure/flow curve on the pump pressure/flow curve, to obtain the desired operating point (see example for 30RA 100). The pressure drop reading in the plate heat exchanger is used to control and adjust the nominal system flow rate. The pressure drop is measured with the pressure gauge connected to the heat exchanger water inlet and outlet.

Use this specification for the unit selection to know the system operating conditions and to deduce the nominal air flow as well as the plate heat exchanger pressure drop at the specified conditions. If this information is not available at the system start-up, contact the technical service department responsible for the installation to get it.

These characteristics can be obtained from the technical literature using the unit performance tables for a  $\Delta T$  of 5 K at the evaporator or with the Electronic Catalogue selection program for all  $\Delta T$  conditions other than 5 K in the range of 3 to 10 K.

### 10.1 - Water flow control procedure

As the total system pressure drop is not known exactly at the start-up, the water flow rate must be adjusted with the control valve provided to obtain the specific flow rate for this application.

#### Proceed as follows:

Open the valve fully (approximately 9 turns counter-clockwise).

Start-up the pump using the forced start command (refer to the controls manual) and let the pump run for two consecutive hours to clean the hydronic circuit of the system (presence of solid contaminants).

Read the plate heat exchanger pressure drop by taking the difference of the readings of the pressure gauge connected to the plate heat exchanger inlet and outlet, using valves (see diagrams below), and comparing this value after two hours of operation.

#### Entering water pressure reading

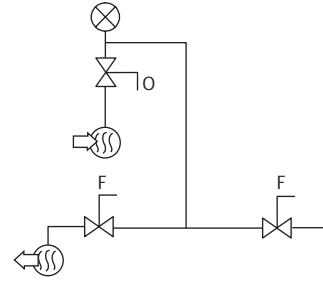

#### Leaving water pressure reading

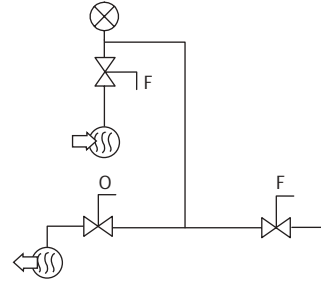

#### Air vent

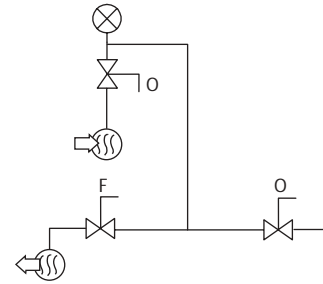

#### Legend

O	Open
F	Closed
	Water inlet
	Water outlet
	Pressure gauge

**NOTE:** Applies to units 040 to 160

If the pressure drop has increased, this indicates that the screen filter must be removed and cleaned, as the hydronic circuit contains solid particles. In this case close the shutoff valves at the water inlet and outlet and remove the screen filter after emptying the hydronic section of the unit.

Renew, if necessary, to ensure that the filter is not contaminated. Purge the air from the circuit (see 'Air vent' diagram).

When the circuit is cleaned, read the pressures at the pressure gauge (entering water pressure - leaving water pressure), expressed in bar and convert this value to kPa (multiply by 100) to find out the plate heat exchanger pressure drop.

Compare the value obtained with the theoretical selection value. If the pressure drop measured is higher than the value specified this means that the flow rate in the plate heat exchanger (and thus in the system) is too high. The pump supplies an excessive flow rate based on the global pressure drop of the application. In this case close the control valve one turn and read the new pressure difference.

Proceed by successively closing the control valve until you obtain the specific pressure drop that corresponds to the nominal flow rate at the required unit operating point.

- If the system has an excessive pressure drop in relation to the available static pressure provided by the pump, the resulting water flow rate will be reduced and the difference between entering and leaving water temperature of the hydronic module will be increased.

To reduce the pressure drops of the hydronic system, it is necessary:

- to reduce the individual pressure drops as much as possible (bends, level changes, accessories, etc.)
- to use a correctly sized piping diameter.
- to avoid hydronic system extensions, wherever possible.

## Pump curve and water flow control as a function of the system pressure drops

Example: 30RA 100 at Eurovent conditions of 4.8 l/s

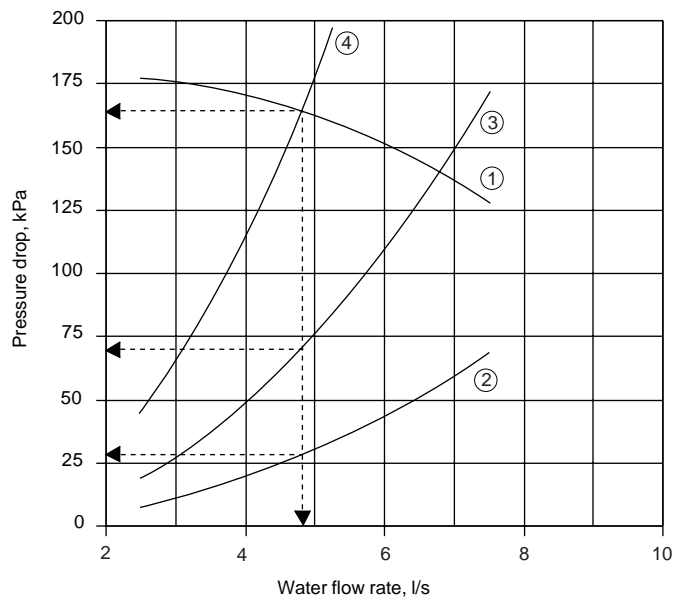

### Legend

- 1 Pump curve, 30RA 100
- 2 Plate heat exchanger pressure drop (to be measured with the pressure gauge installed at the water inlet and outlet)
- 3 Installation pressure drop with control valve wide open
- 4 Installation pressure drop after valve control to obtain nominal flow rate

## 10.2 - Pump pressure/flow rate curves

### Single pumps

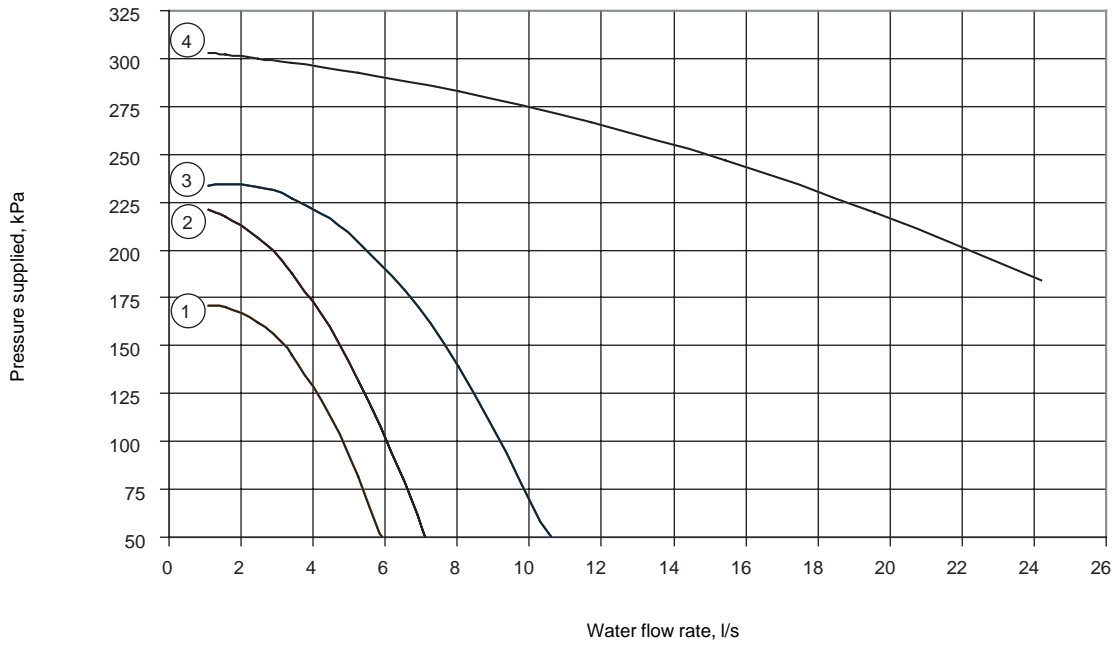

#### Legend

- 1 30RA 040-070
- 2 30RA 080-100
- 3 30RA 120-160
- 4 30RA 200-240

### Dual pumps

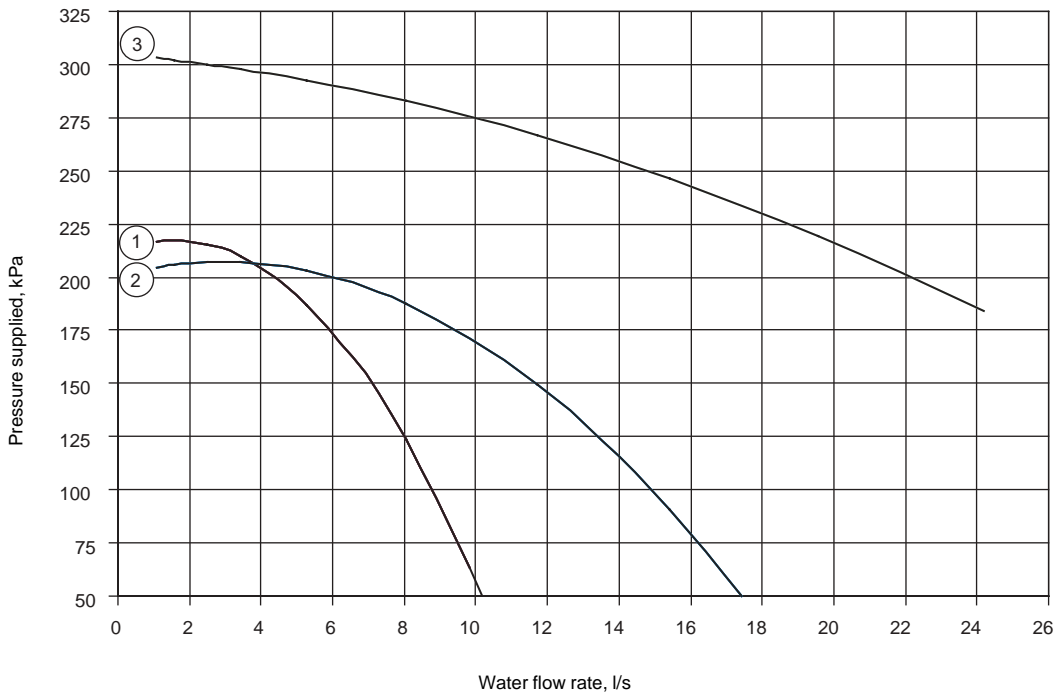

#### Legend

- 1 30RA 040-100
- 2 30RA 120-160
- 3 30RA 200-240



### 10.3 - Available static system pressure

#### Single pumps

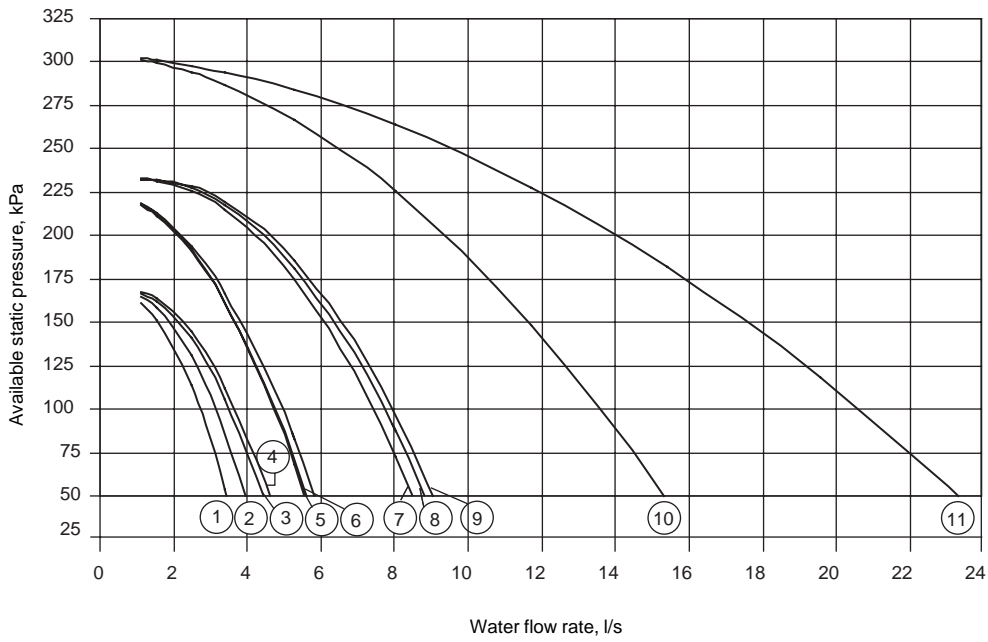

**Legend**

- 1 30RA 040
- 2 30RA 050
- 3 30RA 060
- 4 30RA 070
- 5 30RA 080-090
- 6 30RA 100
- 7 30RA 120
- 8 30RA 140
- 9 30RA 160
- 10 30RA 200
- 11 30RA 240

#### Dual pumps

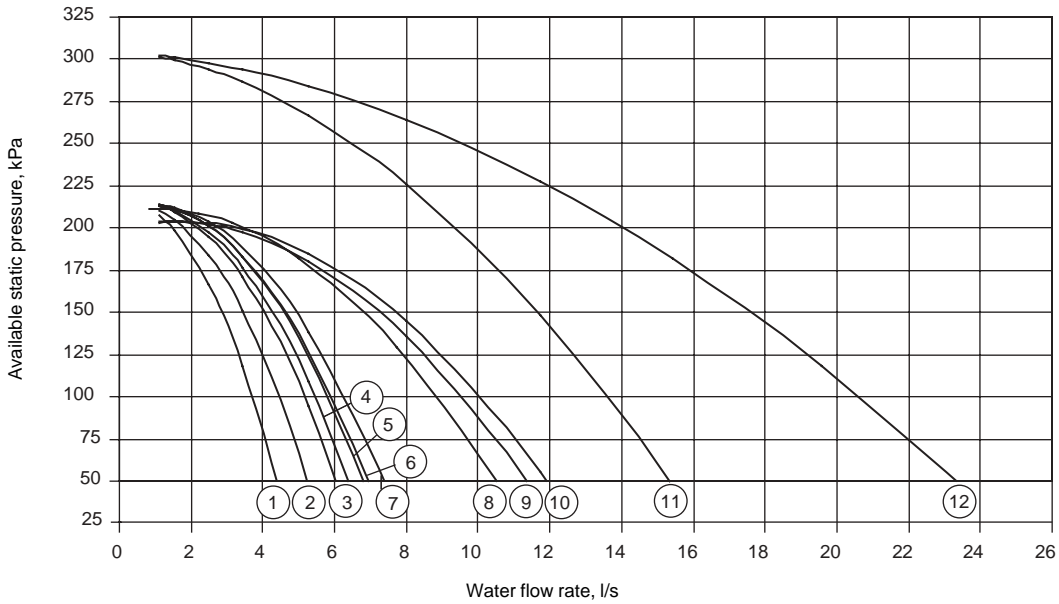

**Legend**

- 1 30RA 040
- 2 30RA 050
- 3 30RA 060
- 4 30RA 070
- 5 30RA 080
- 6 30RA 090
- 7 30RA 100
- 8 30RA 120
- 9 30RA 140
- 10 30RA 160
- 11 30RA 200
- 12 30RA 240

## 11 - START-UP

### 11.1 - Preliminary checks

- Never be tempted to start the chiller without reading fully, and understanding, the operating instructions and without having carried out the following pre-start checks:
- Check the chilled water circulation pumps, air handling units and all other equipment connected to the evaporator.
- Refer to the manufacturer's instructions.
- For units without hydronic module, the water pump overheat protection device must be connected in series with the pump contactor power supply. If the pump is not supplied with the unit (unit without hydronic module), verify that the power input of the field-installed pump does not exceed the rating of the standard pump contactor, supplied in the control box (max. 3 kW for sizes 040 to 160 and max. 5.5 kW for sizes 200 and 240).
- Refer to the wiring diagram supplied with the unit.
- Ensure that there are no refrigerant leaks.
- Confirm that all pipe securing bands are tight.
- Confirm the the electrical connections are secure.

### 11.2 - Actual start-up

#### IMPORTANT

- *Commissioning and start-up of the chiller must be supervised by a qualified refrigeration engineer.*
- *Start-up and operating tests must be carried out with a thermal load applied and water circulating in the evaporator.*
- *All set-point adjustments and control tests must be carried out before the unit is started up.*
- *Please refer to the controls section of this manual.*

The unit should be started up in Local ON mode. Ensure that all safety devices are satisfied, especially the high pressure switches.

### 11.3 - Operation of two units in master/slave mode

The control of a master/slave assembly is in the entering water and does not require any additional sensors (standard configuration). It can also be located in the leaving water. In this case two additional sensors must be added on the common piping.

All parameters, required for the master/slave function must be configured using the Service Configuration menu. All remote controls of the master/slave assembly (start/stop, set point, load shedding etc.) are controlled by the unit configured as master and must only be applied to the master unit.

Depending on the installation and control type, each unit can control its own water pump. If there is only one common pump for the two units, the master unit can control this. In this case shut-off valves must be installed on each unit. They will be activated at the opening and closing by the control of each unit (and the valves will be controlled using the dedicated water pump outputs).

#### 30RA 040 to 240 (standard configuration: return water control)

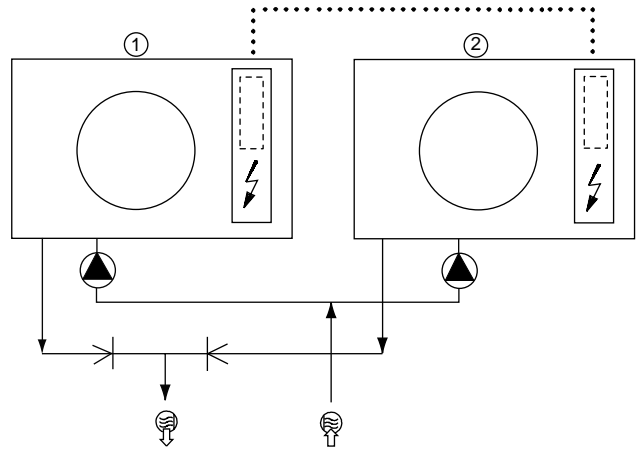

#### 30RA 090 to 240 (with configuration: leaving water control)

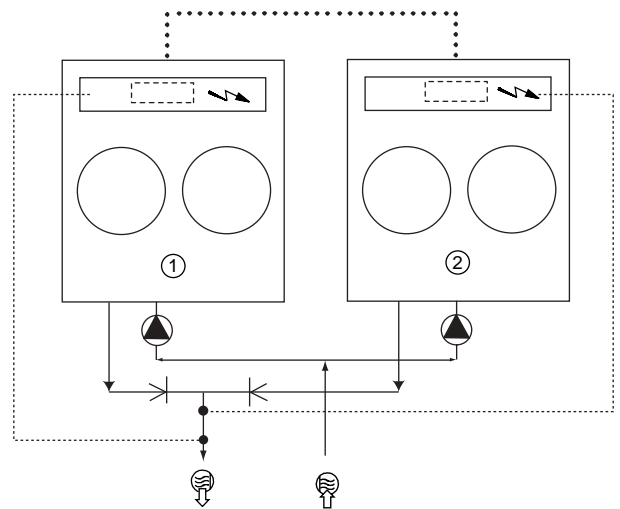

#### Legend

- 1 Master unit
- 2 Slave unit
- Additional CCN board (one per unit, with connection via communication bus)
- ⚡ Control boxes of the master and slave units
- ⊕ Water inlet
- ⊖ Water outlet
- ⚙ Water pumps for each unit (included as standard for units with hydronic module)
- Additional sensors for leaving water control, to be connected to channel 1 of the slave boards of each master and slave unit
- ... CCN communication bus
- ..... Connection of two additional sensors

## 12 - MAINTENANCE

Any technician attending the machine for any purpose must be fully qualified to work on refrigerant and electrical circuits.

*All refrigerant charging, removal and draining operations must be carried out by a qualified technician and with the correct material for the unit. Any inappropriate handling can lead to uncontrolled fluid or pressure leaks.*

**WARNING:** Before doing any work on the machine ensure that the power is switched off. If a refrigerant circuit is opened, it must be evacuated, recharged and tested for leaks. Before any operation on a refrigerant circuit, it is necessary to remove the complete refrigerant charge from the unit with a refrigerant charge recovery group.

### 12.1 - General maintenance of the refrigerant circuit

- Keep the unit itself and the space around it clean and free of obstructions. Remove all rubbish such as packing materials, as soon as the installation is completed.
- Regularly clean the exposed pipework to remove all dust and dirt. This makes detection of water leaks easier, and they can be repaired before more serious faults develop.
- Confirm that all screwed and bolted connections and joints are secure. Secure connections prevent leaks and vibration from developing.
- Check that all insulation joints are securely closed and that all insulation is firmly in place. Check all heat exchangers and all pipework.

### 12.2 - Refrigerant charge

#### 12.2.1 - Verification of the charge

**CAUTION:** The 30RA units are supplied with a precise R407C refrigerant charge (see Physical Data table).

To verify the correct system charge proceed as follows:

Ensure that no bubbles appear in the sight-glass, when operating the unit at full load for a while, at a saturated condensing temperature of between 55 and 57°C. If necessary cover a section of the coil surface to obtain this condensing temperature. Under these conditions the apparent subcooling which is equal to the saturated condensing temperature (1 - on the saturated dew point curve) minus the liquid refrigerant temperature (3) ahead of the expansion device must be between 12 and 14°C. This corresponds to an actual subcooling temperature of between 5 and 7 K at the condenser outlet, depending on the unit type. Actual subcooling is equal the saturated liquid temperature (2 - on the saturated bubble point curve) minus the liquid refrigerant temperature (3) ahead of the expansion device. Use the pressure tap supplied on the liquid piping to charge refrigerant and to find out the pressure of the liquid refrigerant. If the subcooling value is not correct, i.e. lower than the specified values, a leak detection test must be carried out on the unit, as it no longer contains its original charge.

In order to measure the liquid refrigerant pressure and temperature ahead of the expansion device, an access port must be opened on the expansion device which causes a slight air bypass on the condenser. Wait until unit operation has stabilized before carrying out pressure and temperature measurements.

**WARNING:** To ensure proper operation of 30RA units there must be at least 12 K of subcooling as the liquid refrigerant enters the expansion valve.

The 30RA units use refrigerant. For your information, we are reproducing here some extracts from the official publication dealing with the design, installation, operation and maintenance of air conditioning and refrigeration systems and the training of people involved in these activities, agreed by the air conditioning and refrigeration industry.

### Apparent and actual subcooling

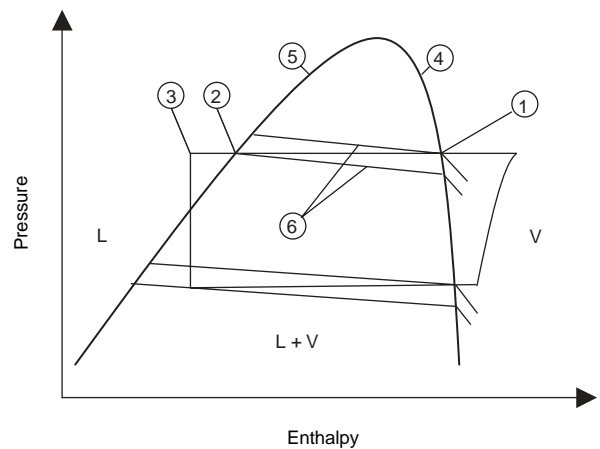

#### Legend

- 1 Saturated condensing temperature at the dew point
- 2 Saturated liquid temperature at the bubble point
- 3 Liquid refrigerant temperature
- 4 Saturation curve at the dew point
- 5 Saturation curve at the bubble point
- 6 Isotherms
- 7 Apparent subcooling (1 - 3)
- 8 Real subcooling (2 - 3)
- L Liquid
- L + V Liquid + vapour
- V Vapour

### 12.2.2 - Principles

Refrigeration installations must be inspected and maintained regularly and rigorously by specialists. Their activities must be overseen and checked by properly trained people. To minimise discharge to the atmosphere, refrigerants and lubricating oil must be transferred using methods which reduce leaks and losses to a minimum and with materials that are suitable for the products.

- Leaks must be repaired immediately
- All units are equipped with two special connections on the suction and liquid line, which permit the connection of quick-connect recovery valves without loss of refrigerant.
- If the residual pressure is too low to make the transfer alone, a purpose-built refrigerant recovery unit must be used.
- Compressor lubricating oil contains refrigerant. Any oil drained from a system during maintenance must therefore be handled and stored accordingly.
- Refrigerant under pressure must never be discharged to the atmosphere.
- If the refrigerant circuit is opened, plug all openings if the operation takes up to one day, or charge the circuit with nitrogen for longer operations.

### 12.2.3 - Recharging liquid refrigerant

**CAUTION:** 30RA units are charged with liquid HFC-407C refrigerant.

*This non-azeotropic refrigerant blend consists of 23% R-32, 25% of R-125 and 52% R-134a, and is characterised by the fact that at the time of the change in state the temperature of the liquid/vapour mixture is not constant, as with azeotropic refrigerants. All checks must be pressure tests, and the appropriate pressure/temperature ratio table must be used to determine the corresponding saturated temperatures (saturated bubble point curve or saturated dew point curve).*

*Leak detection is especially important for units charged with refrigerant R407C. Depending on whether the leak occurs in the liquid or in the vapour phase, the proportion of the different components in the remaining liquid is not the same.*

**NOTE:** Regularly carry out leak checks and immediately repair any leak found. If there is a leak in the plate heat exchanger, this part must be replaced.

### 12.2.4 - Undercharge

If there is not enough refrigerant in the system, this is indicated by gas bubbles in the moisture sight glass.

If the undercharge is significant, large bubbles appear in the moisture sight glass, and the suction pressure drops. The compressor suction superheat is also high. The machine must be recharged after the leak has been repaired.

Find the leak and completely drain the system with a refrigerant recovery unit. Carry out the repair, leak test and then recharge the system.

**IMPORTANT:** After the leak has been repaired, the circuit must be tested, without exceeding the maximum low-side operating pressure shown on the unit name plate.

The refrigerant must always be recharged in the liquid phase into the liquid line.

The refrigerant cylinder must always contain at least 10% of its initial charge.

For the refrigerant quantity per circuit, refer to the data on the unit name plate.

### 12.2.5 - Characteristics of R407C

See the table below.

Saturated bubble point temperatures (bubble point curve)

Saturated dew point temperatures (dew point curve)

### 12.3 - Electrical maintenance

When working on the unit comply with all safety precautions described in section "Maintenance safety considerations".

- It is strongly recommended to change the fuses in the units every 15000 operating hours or every 3 years.
- It is recommended to verify that all electrical connections are tight:
  - a. after the unit has been received at the moment of installation and before the first start-up,
  - b. one month after the first start-up, when the electrical components have reached their nominal operating temperatures,
  - c. then regularly once a year.

## R407C characteristics

Bar (relative)	Saturated bubble point temp. °C	Saturated dew point temp. °C	Bar (relative)	Saturated bubble point temp. °C	Saturated dew point temp. °C	Bar (relative)	Saturated bubble point temp. °C	Saturated dew point temp. °C
1	-28.55	-21.72	10.5	23.74	29.35	20	47.81	52.55
1.25	-25.66	-18.88	10.75	24.54	30.12	20.25	48.32	53.04
1.5	-23.01	-16.29	11	25.32	30.87	20.5	48.83	53.53
1.75	-20.57	-13.88	11.25	26.09	31.62	20.75	49.34	54.01
2	-18.28	-11.65	11.5	26.85	32.35	21	49.84	54.49
2.25	-16.14	-9.55	11.75	27.6	33.08	21.25	50.34	54.96
2.5	-14.12	-7.57	12	28.34	33.79	21.5	50.83	55.43
2.75	-12.21	-5.7	12.25	29.06	34.5	21.75	51.32	55.9
3	-10.4	-3.93	12.5	29.78	35.19	22	51.8	56.36
3.25	-8.67	-2.23	12.75	30.49	35.87	22.25	52.28	56.82
3.5	-7.01	-0.61	13	31.18	36.55	22.5	52.76	57.28
3.75	-5.43	0.93	13.25	31.87	37.21	22.75	53.24	57.73
4	-3.9	2.42	13.5	32.55	37.87	23	53.71	58.18
4.25	-2.44	3.85	13.75	33.22	38.51	23.25	54.17	58.62
4.5	-1.02	5.23	14	33.89	39.16	23.5	54.64	59.07
4.75	0.34	6.57	14.25	34.54	39.79	23.75	55.1	59.5
5	1.66	7.86	14.5	35.19	40.41	24	55.55	59.94
5.25	2.94	9.11	14.75	35.83	41.03	24.25	56.01	60.37
5.5	4.19	10.33	15	36.46	41.64	24.5	56.46	60.8
5.75	5.4	11.5	15.25	37.08	42.24	24.75	56.9	61.22
6	6.57	12.65	15.5	37.7	42.84	25	57.35	61.65
6.25	7.71	13.76	15.75	38.31	43.42	25.25	57.79	62.07
6.5	8.83	14.85	16	38.92	44.01	25.5	58.23	62.48
6.75	9.92	15.91	16.25	39.52	44.58	25.75	58.66	62.9
7	10.98	16.94	16.5	40.11	45.15	26	59.09	63.31
7.25	12.02	17.95	16.75	40.69	45.71	26.25	59.52	63.71
7.5	13.03	18.94	17	41.27	46.27	26.5	59.95	64.12
7.75	14.02	19.9	17.25	41.85	46.82	26.75	60.37	64.52
8	14.99	20.85	17.5	42.41	47.37	27	60.79	64.92
8.25	15.94	21.77	17.75	42.98	47.91	27.25	61.21	65.31
8.5	16.88	22.68	18	43.53	48.44	27.5	61.63	65.71
8.75	17.79	23.57	18.25	44.09	48.97	27.75	62.04	66.1
9	18.69	24.44	18.5	44.63	49.5	28	62.45	66.49
9.25	19.57	25.29	18.75	45.17	50.02	28.25	62.86	66.87
9.5	20.43	26.13	19	45.71	50.53	28.5	63.27	67.26
9.75	21.28	26.96	19.25	46.24	51.04	28.75	63.67	67.64
10	22.12	27.77	19.5	46.77	51.55	29	64.07	68.02
10.25	22.94	28.56	19.75	47.29	52.05	29.25	64.47	68.39

### 12.4 - Condenser coil

We recommend, that finned coils are inspected regularly to check the degree of fouling. This depends on the environment where the unit is installed, and will be worse in urban and industrial installations and near trees that shed their leaves.

For coil cleaning proceed as follows:

- Remove fibres and dust collected on the condenser face with a soft brush (or vacuum cleaner).
- Clean the coil with the appropriate cleaning agents.

We recommend TOTALINE products for coil cleaning:

Part No. P902 DT 05EE: traditional cleaning method

Part No. P902 CL 05EE: cleaning and degreasing.

These products have a neutral pH value, do not contain phosphates, are not harmful to the human body, and can be disposed of through the public drainage system. Depending on the degree of fouling both products can be used diluted or undiluted.

For normal maintenance routines we recommend using 1 kg of the concentrated product, diluted to 10%, to treat a coil surface of 2 m<sup>2</sup>. This process can either be carried out with a TOTALINE applicator gun (part No. TE01 WA 4000EE) or using a high-pressure spray gun in the low-pressure position. With pressurised cleaning methods care should be taken not to damage the coil fins. The spraying of the coil must be done:

- in the direction of the fins
- in the opposite direction of the air flow direction
- with a large diffuser (25-30°)
- at a distance of 300 mm.

The two cleaning products can be used for any of the following coil finishes: Cu/Cu, Cu/Al, Cu/Al with Polual, Blygold and/or Heresite protection.

It is not necessary to rinse the coil, as the products used are pH neutral. To ensure that the coil is perfectly clean, we recommend rinsing with a low water flow rate. The pH value of the water used should be between 7 and 8.

***WARNING: Never use pressurized water without a large diffusor. Concentrated and/or rotating water jets are strictly forbidden.***

***Correct and frequent cleaning (approximately every three months) will prevent 2/3 of the corrosion problems.***

***Never use a fluid with a temperature above 45°C to clean the air heat exchangers.***

## 13 - AQUASNAP MAINTENANCE PROGRAM

All maintenance operations must be carried out by technicians who have been trained on Carrier products, observing all Carrier quality and safety standards.

### Maintenance instructions

During the unit operating life the service checks and tests must be carried out in accordance with applicable national regulations.

If there are no similar criteria in local regulations, the information on checks during operation in annex C of standard EN 378-2 can be used.

External visual checks: annex A and B of standard EN 378-2

Corrosion checks: annex D of standard EN 378-2. These controls must be carried out:

- After an intervention that is likely to affect the resistance or a change in use or change of high-pressure refrigerant, or after a shut down of more than two years. Components that do not comply, must be changed. Test pressures above the respective component design pressure must not be applied (annex B and D).
- After repair or significant modifications or significant system or component extension (annex B)
- After re-installation at another site (annexes A, B and D)
- After repair following a refrigerant leak (annex D). The frequency of refrigerant leak detection can vary from once per year for systems with less than 1% leak rate per year to once a day for systems with a leak rate of 35% per year or more. The frequency is in proportion with the leak rate.

**NOTE: High leak rates are not acceptable. The necessary steps must be taken to eliminate any leak detected.**

**NOTE 2: Fixed refrigerant detectors are not leak detectors, as they cannot locate the leak.**

### 13.1 - Maintenance schedule

Regular maintenance is indispensable to optimise the operating life and reliability of the equipment. Maintenance operations must be carried out in accordance with the schedules below:

Service	Frequency
A	Weekly
B	Monthly
C	Annually
D	Special cases

If the equipment does not operate normally during maintenance operations, please refer to the paragraph on diagnostics and breakdowns of the '30RA/RH - 30RY/RH "B" Pro-Dialog Plus' controls manual.

**IMPORTANT: Before each equipment maintenance operation please ensure that:**

- *the unit is in the OFF position*
- *it is impossible for the unit to restart automatically during maintenance.*

### 13.2 - Description of the maintenance operations

The equipment is supplied with polyolester oil (POE). Only use oil approved by Carrier. On request Carrier can carry out an oil analysis of your installation.

#### Service A

##### Full-load operating test

Verify the following values:

- compressor high-pressure side discharge pressure
- compressor low-pressure side suction pressure
- charge visible in the sight glass
- temperature difference between the heat exchanger water entering and leaving temperature.

##### Verify the alarm status

#### Service B

Carrier out the operations listed under Service A.

##### Refrigerant circuit

- Verify the air heat exchanger cleanliness status and clean it at least once a year, or more often if the equipment environment is especially demanding. To clean the equipment, follow the Carrier recommendations. Among other things, this ensures that the unit performances can be guaranteed.
- Full-load operating test. In addition to the operations described under Service A, check the following values:
  - compressor discharge pressure
  - compressor oil level
  - actual liquid subcooling
  - overheating at the expansion device
  - on heat pumps verify correct defrost of the air heat exchanger.
- Verify the charge status by checking the colour indicator of the sight glass. If the colour has turned to yellow, change the charge and replace the filter drier after carrying out a leak test of the circuit.

##### Electrical checks

- Check the tightening of the electric connections, contactors, disconnect switch and transformer.
- Check the status of the contactors, fuses and capacitors, as required.
- Carry out a quick test (refer to the manual for the Aquasnap Pro-Dialog Plus control).

##### Mechanical checks

- Verify that nothing impedes the rotation of the fan impeller of the air heat exchanger.

##### Water circuit checks

- Check the leak-tightness of the circuit.

## Service C

Carry out the operations listed under Service B.

### Refrigerant circuit

- Check the leak-tightness of the circuit and ensure that there is no piping damage.
- Carry out an oil contamination test. If acid, water or metallic particles are present replace the oil in the circuit.
- Verify the tightening of the thermostatic mechanism of the expansion device.
- Full-load operating test. In addition to the checks carried out under Service B, validate the values of the heat exchanger inlet and outlet tightening.
- Check the operation of the high-pressure and low-pressure switches. Replace them if there is a fault.
- Check the fouling of the filter drier (by checking the temperature difference in the copper piping). Replace it if necessary.

### Electrical checks

- Check the status of the electrical cables and their insulation.
- Carry out an operating test of the electric evaporator heaters, compressor crankcase heater, piping and expansion device, as required.
- Check the phase/earth insulation of the compressors, fans and pumps.
- Check the compressor, fan and pump winding status.

### Mechanical checks

- Check the tightening of the fan tower, fan, compressor and control box fixing bolts.
- Check that no water has penetrated into the control box.
- All metallic parts of the unit (chassis, casing panels, control boxes, heat exchangers etc.) are protected against corrosion by a coating of powder or liquid paint. To prevent the risk of blistering corrosion that can appear when moisture penetrates under the protective coatings, it is necessary to carry out periodic checks of the coating (paint) condition.

### Water circuit checks

- Clean the water filter.
- Purge the circuit with air.
- Verify the correct operation of the water flow switch.
- Check the status of the thermal piping insulation.
- Check the water flow by checking the heat exchanger pressure difference (using a pressure gauge).
- Check the concentration of the anti-freeze protection solution (ethylene glycol or polyethylene glycol).- Check the status of the heat transfer fluid or the water quality.
- Check the steel pipe corrosion.

## Service D

- Single pump and dual pump.
  - Mechanical seal: replace this every 13000 operating hours.
  - Bearing: replace this every 20000 operating hours.

# 14 - START-UP CHECKLIST FOR 30RA LIQUID CHILLERS (USE FOR JOB FILE)

## Preliminary information

Job name: .....  
Location: .....  
Installing contractor: .....  
Distributor: .....  
Start-up preformed by: ..... Date: .....

## Equipment

Model 30RA: ..... S/N .....

## Compressors

### Circuit A

1. Model # ..... S/N .....

### Circuit B

1. Model # ..... S/N .....

2. Model # ..... S/N .....

3. Model # ..... S/N .....

## Air handling equipment

Manufacturer .....  
Model # ..... S/N .....

Additional air handling units and accessories .....

## Preliminary equipment check

Is there any shipping damage? ..... If so, where? .....  
Will this damage prevent unit start-up? .....

- Unit is level in its installation
- Power supply agrees with the unit name plate
- Electrical circuit wiring has been sized and installed properly
- Unit ground wire has been connected
- Electrical circuit protection has been sized and installed properly
- All terminals are tight
- All cables and thermistors have been inspected for crossed wires
- All plug assemblies are tight

## Check air handling systems

- All air handlers are operating
- All chilled water valves are open
- All fluid piping is connected properly
- All air has been vented from the system
- Chilled water pump is operating with the correct rotation. CWP amperage: Rated: ..... Actual.....



**Unit start-up**

- Chilled water pump starter has been properly interlocked with the chiller
- Oil level is correct
- Unit has been leak checked (including fittings)
- Locate, repair, and report any refrigerant leaks

.....  
 .....  
 .....

Check voltage imbalance: AB ..... AC ..... BC.....  
 Average voltage = ..... (see installation instructions)  
 Maximum deviation = ..... (see installation instructions)  
 Voltage imbalance = ..... (see installation instructions) .

- Voltage imbalance is less than 2%

**WARNING**

*Do not start chiller if voltage imbalance is greater than 2%. Contact local power company for assistance.*

- All incoming power voltage is within rated voltage range

**Check evaporator water loop**

Water loop volume = ..... (litres)  
 Calculated volume = ..... (litres)  
 2.50 litres/nominal kW capacity for air conditioning (30RA 050 to 240)  
 3.50 litres/nominal kW capacity for air conditioning (30RA 040)

- Proper loop volume established
- Proper loop corrosion inhibitor included ..... litres of.....
- Proper loop freeze protection included (if required) ..... litres of .....
- Water piping includes electric tape heater up to the evaporator
- Return water piping is equipped with a screen filter with a mesh size of 1.2 mm

**Check pressure drop across the evaporator**

Entering evaporator = ..... (kPa)  
 Leaving evaporator = ..... (kPa)  
 Pressure drop (entering - leaving) = ..... (kPa)

**WARNING**

*Plot the pressure drop on the evaporator flow/pressure drop curve to determine the flow rate in l/s at the nominal operating conditions for the installation.*

*If necessary use the control valve to impose the flow rate on the nominal value.*

- Flow rate from the pressure drop curve, l/s = .....
- Nominal flow rate, l/s = .....
- The flow rate in l/s is higher than the minimum unit flow rate
- The flow rate in l/s corresponds to the specification of ..... (l/s)

Carry out the QUICK TEST function (see 30RA/RH - 30RY/Ryh "B" Pro-Dialog Plus Control manual):

**Check and log on to the user menu configuration**

- Load sequence selection .....
- Capacity ramp loading selection .....
- Start-up delay .....
- Burner section .....
- Pump control .....
- Set-point reset mode .....
- Night-time capacity setback .....

**Re-enter the set-points (see Controls section)**

**To start up the chiller**

**WARNING**

*Be sure that all service valves are open, and that the pump is on before attempting to start this machine. Once all checks have been made, start the unit in the "LOCAL ON" position.*

Unit starts and operates properly

**Temperatures and pressures**

**WARNING**

*Once the machine has been operating for a while and the temperatures and pressures have stabilized, record the following*

- Evaporator entering water .....
- Evaporator leaving water .....
- Ambient temperature .....
- Circuit A suction pressure .....
- Circuit B suction pressure .....
- Circuit A discharge pressure .....
- Circuit B discharge pressure .....
- Circuit A suction temperature .....
- Circuit B suction temperature .....
- Circuit A discharge temperature .....
- Circuit B discharge temperature .....
- Circuit A liquid line temperature .....
- Circuit B liquid line temperature .....

**NOTES:**

.....  
.....  
.....





Order No.: 13435-76, 09.2003 - Supersedes order No.: 13435-76, 04.2002.  
Manufacturer reserves the right to change any product specifications without notice.



Environmental Management System Approval

Manufactured by: Carrier SA, Montluel, France  
Printed in the Netherlands  
Printed on totally chlorine-free paper.