



30GX and 30HXC series PRO-DIALOG *Plus* Control

Screw-Compressor Air- and
Water-Cooled Liquid Chillers

50 Hz



GLOBAL CHILLER

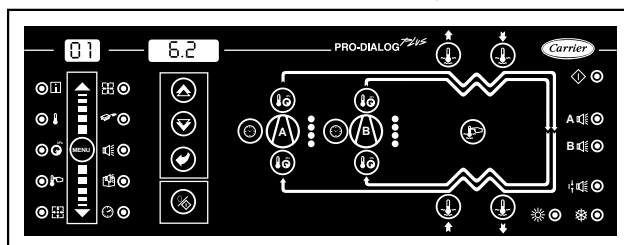
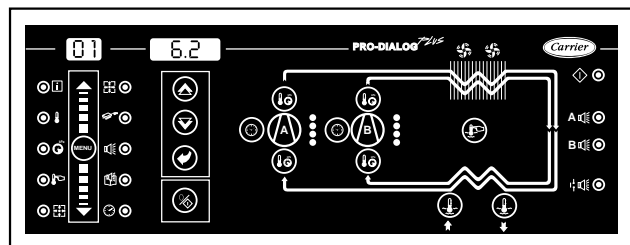

Installation, operation and maintenance instructions



Quality Management System Approval

Table of contents

1 - SAFETY CONSIDERATIONS	4
1.1 - General	4
1.2 - Avoiding electrocution	4
2 - GENERAL DESCRIPTION	4
2.1 - General	4
2.2 - Abbreviations used	4
3 - HARDWARE DESCRIPTION	5
3.1 - General	5
3.2 - Electronic boards	5
3.2.1 - The basic board	5
3.2.2 - Slave boards	5
3.2.3 - The user interface	6
3.2.4 - Connections between boards	6
3.2.5 - Slave board address	6
3.2.6 - Power supply to the boards	6
3.2.7 - Light emitting diodes on boards	6
3.3 - The controls	7
3.3.1 - Electronic expansion valve EXV	7
3.3.2 - The head pressure controls	7
3.3.3 - The evaporator pump	7
3.3.4 - The condenser pump	7
3.3.5 - The evaporator heater	7
3.3.6 - Pressure sensors	7
3.3.7 - Thermistors	8
3.4 - Connections at customer's terminal block	8
3.4.1 - Fault reporting on circuits A and B	8
3.4.2 - Evaporator pump contactor control	8
3.4.3 - Condenser pump contactor control	8
3.4.4 - Evaporator heater contactor control	9
3.4.5 - Remote start/stop volt-free contact	9
3.4.6 - Remote volt-free contact for cooling temperature setpoint selection	9
3.4.7 - Remote heat/cool volt-free contact	9
3.4.8 - Remote heat reclaim volt-free contact	9
3.4.9 - Demand limit volt-free contact	9
3.4.10 - Evaporator water loop control and condenser water flow or thermostat box control volt-free contacts	9
3.4.11 - 0-10 V d.c. input for setpoint reset or demand limit	10
3.4.12 - Condenser water valve control contacts	10
3.4.13 - 24 V a.c. contact	10
3.4.14 - Connections to the CCN	10
3.4.15 - Heat reclaim condenser water valve connection	10
4 - SETTING UP PRO-DIALOG PLUS CONTROL	11
4.1 - General	11
4.2 - Main interface	11
4.2.1 - Description	11
4.2.2 - Operating types	11
4.2.3 - Displaying/modifying a menu item	12
4.2.4 - Description of the INFORMATION menu	15
4.2.5 - Description of the TEMPERATURES menu	17
4.2.6 - Description of the PRESSURE menu	17
4.2.7 - SETPOINT menu	18
4.2.8 - Description of the INPUT menu	21
4.2.9 - Description of the OUTPUT/TEST menu	23

The cover photograph is solely for illustration, and forms no part of any offer for sale or any sale contract. The manufacturer reserves the right to change the design at any time without notice.

4.2.10 - Description of the CONFIGURATION menu	24
4.2.11 - Description of the ALARMS menu	25
4.2.12 - Description of the ALARMS HISTORY menu	26
4.2.13 - Description of the OPERATING LOG menu	26
4.2.14 - Default user interface display	26
4.3 - Summary interface	27
4.3.1 - General	27
4.3.2 - Description of the LEDs	27
4.3.3 - The push buttons	27
5 - PRO-DIALOG PLUS CONTROL OPERATION	28
5.1 - Start/stop control	28
5.2 - Heating/cooling selection	28
5.3 - Evaporator water pump control	28
5.4 - Condenser water pump control	28
5.5 - Control point	28
5.5.1 - Active setpoint	28
5.5.2 - Reset	28
5.6 - Demand limit	28
5.7 - Capacity control	29
5.8 - Determining the lead circuit	29
5.9 - Circuit loading sequence	29
5.10 - Compressor start-up sequence in one circuit	29
5.11 - Controlling the EXV	29
5.12 - Motor cooling valve control	30
5.13 - Head pressure control on air-cooled units	30
5.14 - Head pressure control on water-cooled units	30
5.15 - Head pressure setpoint selection	30
5.16 - High pressure load shedding function	30
5.17 - Start-up procedure - prelubrication	30
5.18 - Master/slave assembly	30
5.18.1 - General	30
5.18.2 - Balancing running times between master and slave	31
5.18.3 - Starting the follower unit	31
5.18.4 - Abnormal operating conditions	31
5.19 - Controlling a Pro-Dialog unit with a System Manager	31
5.20 - Optional heat reclaim module	31
6 - DIAGNOSTICS - TROUBLESHOOTING	32
6.1 - General	32
6.2 - Displaying alarms	32
6.3 - Resetting alarms	32
6.4 - Description of the alarm codes	32

1 - SAFETY CONSIDERATIONS

1.1 - General

Installation, start-up and servicing of equipment can be hazardous if factors particular to the installation are not considered: operating pressures, electrical components, voltages and the installation site itself (elevated plinths, rooftops and built-up structures).

Only highly trained and qualified installation engineers and technicians, who are fully trained on the product, are authorised to install and start up this equipment.

During all servicing operations, it is important to read, understand and follow all the recommendations and instructions given in the installation and service instructions for the product, including the tags and labels affixed to the equipment, components and any parts supplied separately, and to comply with all other relevant safety regulations.

- Apply all safety codes and practices.
- Wear safety glasses and gloves.
- Use the proper tools to move heavy objects. Move units carefully and set them down gently.

1.2 - Avoiding electrocution

Only personnel qualified in accordance with the recommendations of the IEC (International Electrotechnical Commission) may be permitted access to electrical components. It is particularly recommended that all sources of electricity to the unit be shut off before any work is begun. Shut off the main power supply at the main circuit breaker or isolator.

IMPORTANT:

Risk of electrocution: Even when the main power isolator or circuit breaker is off, it is still possible for certain components such as crankcase heaters and trace heaters to be energised, since they are connected to a separate power source.

Risk of burns: Electrical currents cause components to get hot either temporarily or permanently. Handle power cables, electrical cables and conduits, terminal box covers and motor frames with very great care.

IMPORTANT: This equipment uses and emits electromagnetic signals. If it is not installed and used in accordance with the instructions given here, it may cause radio interference. It has been tested and shown to comply with all applicable codes regarding electromagnetic compatibility.

2 - GENERAL DESCRIPTION

2.1 - General

PRO-DIALOG Plus is a system for controlling units which use screw compressors:

- Single or dual circuit
- Air or water-cooled condensers
- Non-reversible heat pumps

PRO-DIALOG Plus controls compressor start-up and demand limits needed to maintain the desired leaving temperature setpoint for water. It automatically sets the position of the electronic expansion valve (if used) to optimise the evaporator charge. It controls operation of the fans (on air-cooled units) or water valves (on water-cooled units) to maintain the correct head pressure in each circuit.

Safety circuits are constantly monitored by PRO-DIALOG Plus to ensure safe operation of the unit. PRO-DIALOG Plus also gives access to a Quick Test program covering all inputs and outputs.

All PRO-DIALOG Plus controls can work in accordance with three independent modes:

- Local mode: the machine is controlled by commands from the user interface.
- Remote mode: the machine is controlled by remote contacts (volt-free contacts, analogue signals).
- CCN mode: the machine is controlled by commands from the Carrier Comfort Network (CCN). In this case a data communication cable is used to connect the unit to the CCN communication bus.

The operating mode must be chosen with the Operating Type selection button described in section 4.2.2.

When the PRO-DIALOG Plus system operates autonomously (Local or Remote mode) it retains all of its own control capabilities but does not offer any of the features of the CCN network.

2.2 - Abbreviations used

In this manual the circuits are called circuit A and circuit B. The compressors in circuit A are labelled A1 and A2. Those in circuit B are labelled B1 and B2.

The following abbreviations are frequently used:

- AI - Analogue Input
- AO - Analogue Output
- CCn - Operating type: CCN
- CCN - Carrier Comfort Network
- CPM - Compressor Protection Module
- DI - Discrete Input
- DO - Discrete Output
- EXV - Electronic eXpansion Valve
- L-C1 - Operating type: Local cooling - setpoint 1
- L-C2 - Operating type: Local cooling - setpoint 2
- L-H - Operating type: Local heating
- LC1r - Operating type: Local cooling - setpoint 1 - heat reclaim
- LC2r - Operating type: Local cooling - setpoint 2 - heat reclaim

- LED - Light Emitting Diode
- Loader - Compressor capacity step
- LOFF - Operating type: Local off
- rEM - Operating type: by remote control contacts
- SCT - Saturated disCharge Temperature
- SIO - Standard Input/Output - internal communication bus linking the basic board to the slave boards
- SST - Saturated Suction Temperature
- TXV - Thermal eXpansion Valve

3 - HARDWARE DESCRIPTION

3.1 - General

The control system consists of at least a basic board and a user interface with, depending on the application, one or more slave boards such as compressor boards, 4xDO boards or 4xAI-2xAO boards. If used, slave boards are connected to the basic board via an internal communication bus (SIO).

The various control components are arranged in modules within the control cabinet:

- **Control module:** This comprises the basic board, the user interface, the EXV control boards (if available) and option boards, as well as the customer's terminal block.
- **Start-up module:** This consists of the start-up boards, compressor protection boards, as well as the compressor circuit breakers and contactors.
- **Fan module (air-cooled unit):** Consists of one or two 4xDO boards together with the fan circuit breakers and contactors.

3.2 - Electronic boards

3.2.1 - The basic board

This board can be used alone or in conjunction with slave boards. It holds the program that controls the machine. It continuously manages the information coming in from the various pressure and temperature sensors, and communicates with the slave boards via the SIO bus. It can also communicate with elements of the Carrier Comfort Network via the CCN bus.

When "conF" shows on the user interface, this means that the basic board must be configured. This can only be done by Carrier Service.

Power interrupt detection: The ACF contacts on J6 detect any interruption or dropout in the power supply. If the contact opens, the unit is immediately shut down and the basic board is re-initialised. This contact must therefore be normally closed when the power to the controller is switched on. After a power dropout, the unit restarts automatically without the need for an external command.

3.2.2 - Slave boards

- **Compressor board CPM:** This board is used to control a compressor. Up to four compressor boards can be connected to the basic board.
- **4xDO board:** This board can be used to control one EXV (with the aid of an additional interface card), various fan stages, loaders, oil pumps or additional motor cooling valves.
- **4xAI-2xAO board:** This board can be used to read sensors (oil pressure, economizer pressure, condensing temperature or reclaim temperature), or to control variable speed fans (air-cooled units) or the condenser valve (water-cooled units).

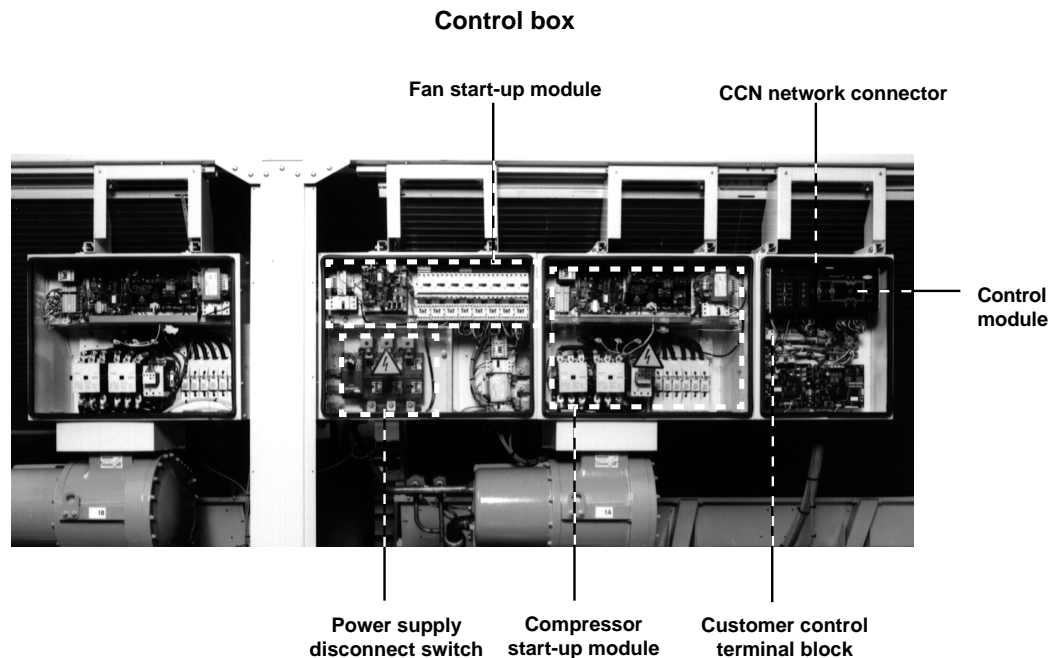

3.2.3 - The user interface

The user interface is in two parts:

- **The main interface:** This gives access to all of the control parameters for the unit. It consists of a 2-digit primary display block and a secondary 4-digit display block with 10 LEDs and 5 buttons.
- **The summary interface:** This gives quick access to just the main control parameters for the unit. It comprises 12 buttons and 16 LEDs, and includes a schematic diagram of the unit.

3.2.4 - Connections between boards

The basic board and slave boards communicate with each other over an internal three-wire RS485 communication bus (SIO bus). These three wires link all the boards in parallel.

Terminals 1, 2 and 3 on connector J4 of the basic board are linked to terminals 1, 2 and 3 of connector J3 (except for CPM boards where terminals 2 and 3 are reversed). Incorrect connection will render the system inoperative.

Fig. 1 - Internal bus wiring (between boards)

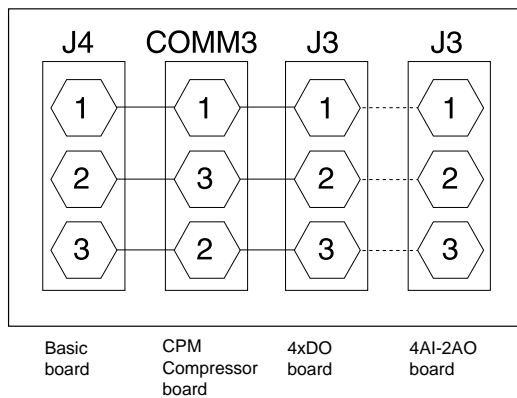

3.2.5 - Slave board addresses

Every slave board (compressor board, 4xDO or 4xAI-2xAO board) has an address which must be set up using the red SIO address switch (marked SIO ADDRESS) at the top righthand corner of each board. This switch consists of 8 DIP switches (except for the CPM boards, equipped with four blue DIP switches). The switch is disabled when it is in the OPEN position - (for CPM boards refer to the text engraved on the printed circuit board).

NOTE: Any incorrect address will prevent the unit from starting. Turn off the power before amending the address of any auxiliary board.

Fig. 2 - Address switch - marked "SIO ADDRESS"

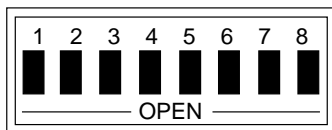

Slave board addresses

BOARD	DIP SWITCH (0 = open)							
	1	2	3	4	5	6	7	8
Board 4xDO #1 EXV circuit A	0	1	0	0	0	0	1	0
Board 4xDO #2 EXV circuit B	0	1	1	0	0	0	1	0
Board 4xDO #3 (fan module) #1	0	0	1	1	1	0	1	0
Board 4xDO #4 (fan module) #2	0	0	0	0	0	1	1	0
Board 4xDO #5 outputs compressor A1	0	0	1	0	0	1	1	0
Board 4xDO #6 outputs compressor A2	0	0	0	1	0	1	1	0
Board 4xDO #7 outputs compressor B1	0	0	1	1	0	1	1	0
Board 4xDO #8 outputs compressor B2	0	0	0	0	1	1	1	0
Board 4 x DO #9 heat reclaim module	0	0	1	0	1	1	1	0
Board 4xAI-2xAO #1	0	1	0	1	0	0	1	0
Board 4xAI-2xAO #2	0	0	0	0	1	0	1	0
Board 4xAI-2xAO #3	0	1	1	0	1	0	1	0

Blue address switch, CPM board (marked ADDRESS)

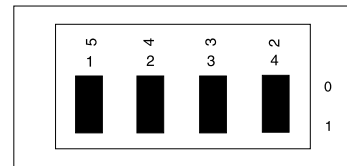

BOARD	DIP SWITCH (0 = open)			
	5	4	3	2
CPM #1 (compressor A 1)	1	0	0	1
CPM #2 (compressor A 2)	1	1	0	1
CPM #3 (compressor B 1)	1	0	1	1
CPM #4 (compressor B 2)	1	1	1	1

3.2.6 - Power supply to the boards

The basic board, the summary interface and the accessory CCN/JBUS board are supplied from a 24 V a.c. **floating supply**. The other boards are supplied by sources that are referred to earth.

BOARDS	CONNECTOR/TERMINAL	SUPPLY 24 V a.c./WIRES
Basic board	J5/O11-O12	011-012
Summary interface	J3	011-012
CCN/JBUS accessory	24 V a.c.	011-012
Compressor module A1		
4xDO for A1	J1/O11-O12	11-1 - (12-1*)
CPM A1	PL-2/5 - 1	11-1 - (12-1*)
Compressor module A2		
4xDO for A2	J1/O11-O12	11-2 - (12-2*)
CPM A2	PL-2/5 - 1	11-2 - (12-2*)
Compressor module B1		
4xDO for B1	J1/O11-O12	11-3 - (12-3*)
CPM B1	PL-2/5 - 1	11-3 - (12-3*)
Compressor module B2		
4xDO for B2	J1/O11-O12	11-4 - (12-4*)
CPM B2	PL-2/5 - 1	11-4 - (12-4*)
EXV Board	J1/O11-O12	11 - 12
Board 4AI - 2xAO	J1/O11-O12	11 - 12
Board 4xDO fan module #1	J1/O11-O12	11-11 - (12-11*)
Board 4xDO fan module #2	J1/O11-O12	12-11 - (12-31*)

* referred to earth

NOTE: When connecting the power supply for the boards, maintain polarity.

In the event of a power supply interrupt, the unit restarts automatically without the need for an external command. However, any faults active when the supply is interrupted are saved and may in certain cases prevent a circuit or unit from restarting.

3.2.7 - Light emitting diodes on boards

All boards continuously check and indicate the proper operation of their electronic circuits. A light emitting diode (LED) lights on each board when it is operating properly.

MAIN red LED - basic and slave boards

- The MAIN red LED flashes at about 2 second intervals to show that the module is working properly.
- If this LED is permanently unlit, the power supply must be checked.
- On slave boards, if this LED is permanently lit there is a problem requiring the board to be changed.
- On the basic board, if this red LED is permanently lit or flashes in turns strongly then weakly, there is either a faulty basic board or a poorly positioned EPROM.

SIO green LED - basic and slave boards

(item SIO on the board)

- This LED flashes continuously to show that the board is communicating correctly over its internal bus.
- If this LED is not flashing, check the wiring of the SIO bus and the address of the board (slave board only). If the basic board is not linked to any slave boards, this LED should not flash.
- If all slave boards indicate a communication fault, check the SIO bus connection on the basic board. If this connection is correct and the fault persists, replace the basic board.

CCN green LED - basic board

(item CCN on the board)

- This LED flashes to show that the basic board is communicating over its CCN bus.

3.3 - The controls

3.3.1 - Electronic expansion valve (EXV)

The EXV is used to adjust the refrigerant flow to changes in the operating conditions of the machine. For this purpose, a series of calibrated orifices are machined into the wall of the refrigerant inlet port. As the refrigerant passes through these orifices, it expands and becomes a bi-phase mixture (liquid and gas).

To adjust the refrigerant flow to changes in operating conditions, a piston moves constantly up or down to vary the cross-section of the refrigerant path. This piston is driven by an electronically controlled linear stepper motor. The high degree of accuracy with which the piston is positioned ensures that the flow of refrigerant is precisely controlled.

NOTE: The external connector of the EXV must be cleaned and coated with silicone grease (Part No. 397 EE) to keep out condensation and prevent corrosion.

3.3.2 - The head pressure controls

The controller can deal with the following:

- in the case of air-cooled units, for each circuit, fan stages together with, if necessary, a variable speed fan (controlled by an 4xAI-2xAO board)
- in the case of water-cooled units, a water valve. This valve is controlled by an 4xAI-2xAO board which can deliver a 0-10 V d.c. or 4-20 mA signal, depending on the configuration.

3.3.3 - The evaporator pump

In appropriate cases the controller can also regulate an evaporator pump. This facility does not require an additional board.

3.3.4 - The condenser pump

In appropriate cases the controller can also regulate a condenser pump (for water-cooled units). This control does not require an additional board.

3.3.5 - The evaporator heater

The evaporator heater can be regulated by the unit control on air-cooled units to protect the evaporator against frost. This control does not require an additional board. If this control is used, evaporator pump control must also be via the unit control.

3.3.6 - Pressure sensors

These are used to measure the following pressures in each circuit:

- Discharge gas pressure
- Suction pressure
- Oil pressure
- Economizer pressure

These electronic sensors deliver 0 to 5 V d.c. to either the basic board or a 4xAI-2xAO slave board. Two types of sensors are used. One is calibrated for the high pressure side and oil pressure and the other for the low pressure side and economizer pressure.

Discharge pressure sensors

These are on the high pressure side of the lead compressor in each circuit. They replace the usual discharge gas pressure gauges and are used as appropriate to control head pressure or by the high pressure load shedding option.

Oil pressure sensors

These sensors, located at the oil pressure port of each compressor, measure the oil pressure to the compressors. The economizer pressure is subtracted from this value to arrive at the differential oil pressure.

Suction pressure sensors

These are used to measure the low pressure side of each circuit. They are located in the high pressure side of the evaporator.

Economizer pressure sensors

These sensors are used to measure the intermediate pressure between high and low pressure. They are used to control the oil pressure differential. They are located on the suction line of the economiser circuit (for units equipped with economizers) or on the cooling line of each motor.

3.3.7 - Thermistors

These all have similar characteristics.

Evaporator entering and leaving water temperature sensor

The evaporator entering water temperature sensor and the leaving water temperature sensor are installed in the entering and leaving side water box.

Discharge gas sensor

This sensor is used to measure the discharge gas temperature, and permits control of the discharge temperature superheat. It is located in the discharge line of each circuit (oiler entering or leaving line, depending on the model).

Motor sensor

This is used to control the motor temperature of each compressor. The terminals of this sensor are situated on the compressor terminal board.

Evaporator liquid level sensor

This is used to measure the refrigerant charging level. It ensures optimised flow control in the evaporator, and is installed at the top of the evaporator.

Condenser entering and leaving water temperature sensors

These are used to control the heating capacity on heat pumps. In cooling only units they have no control function. They are installed in the common condenser entering and leaving line.

Heat reclaim condenser entering/leaving water temperatures

These sensors measure the entering and leaving water temperatures of heat reclaim condensers and are used on air-cooled units. They may be fitted as options.

Temperature setpoint reset sensor

This is an optional 0-10 V sensor which can be installed remotely from the unit. It is used to reset the cooling and heating setpoint on the unit as a function of either the outdoor air temperature or ambient room temperature. The sensor is not supplied by Carrier. Its characteristics must be configured by Carrier Service. See section 3.4.10 for connection instructions.

3.4 - Connections at customer's terminal block

The connections below are available at the customer's terminal block. Some of them can only be used in special operating modes. For further details see the sections that describe the functions (section 5) and the configurations (section 4.2.10).

NOTE: The bridge between terminals 32, 63 and 65 on the customer's terminal block must not be removed.

3.4.1 - Fault reporting on circuits A and B

These are live contacts. They must be supplied with 24 V a.c. and maximum current 0.5 A*.

Fig. 3 - Fault report alarm connections

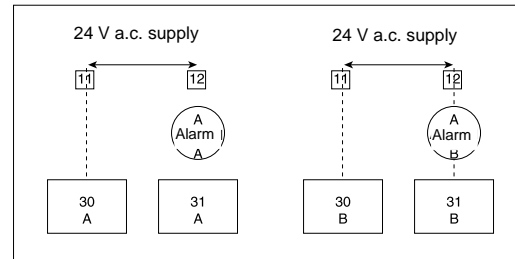

NOTE: To obtain a volt-free dry alarm contact, these outputs must be interfaced with a relay supplied with 24 V a.c. (Carrier Part No. —OK—12AC-034—EE).

3.4.2 - Evaporator pump contactor control

The evaporator pump contactor can be supplied with 24 V a.c. and a maximum current of 0.5 A* between terminals 12 and 90.

Fig. 4 - Evaporator pump connections

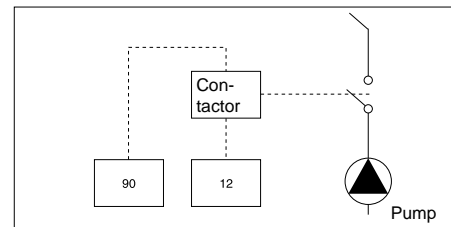

3.4.3 - Condenser pump contactor control

The condenser pump contactor can be supplied with 24 V a.c. and a maximum current of 0.5 A* between terminals 95 and 12.

Fig. 5 - Condenser pump connections

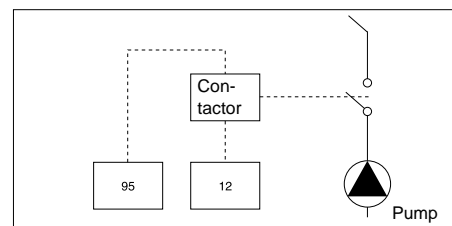

3.4.4 - Evaporator heater contactor control

The evaporator heater contactor can be supplied with 24 V a.c. and a maximum current of 0.5 A* between terminals 41 and 12.

Fig. 6 - Evaporator heater connections

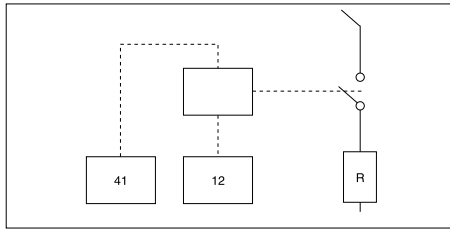

3.4.5 - Remote stop/start volt-free contact**

The remote stop/start contact is only taken into account if the unit is in remote control operating type (rEM). See section 4.2.2.

Remote stop/start connections

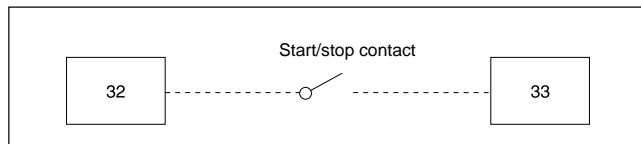

Key:
Contact open: unit stopped
Contact closed: start command

NOTE: In exceptional circumstances this contact can be configured as active (configuration by Carrier Service) if the unit operates in CCN mode as part of a master-slave link (see section 5.18).

3.4.6 - Remote volt-free contact for cooling temperature setpoint selection**

The remote contact for cooling setpoint selection is only taken into account if the unit is in remote control operating type (rEM). See section 4.2.2.

Connection for remote setpoint selection

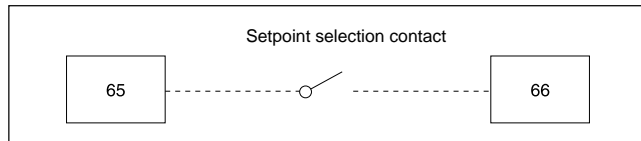

Key:
Contact open: cooling setpoint 1
Contact closed: cooling setpoint 2

3.4.7 - Remote heat/cool volt-free contact**

The remote heat/cool selection contact is only taken into account if the unit is in remote control operating type (rEM). See section 4.2.2.

Connection for remote heat/cool selection

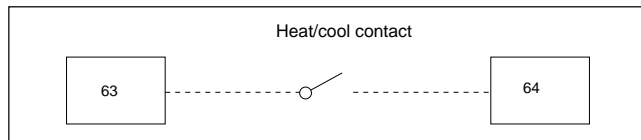

Key
Contact open: cool
Contact closed: heat

3.4.8 - Remote heat reclaim volt-free contact**

This control is used to select the second condensing setpoint or the heat reclaim mode. It is only taken into account if the unit is in remote control operating type (rEM). See section 4.2.2.

Connection for heat reclaim mode selection

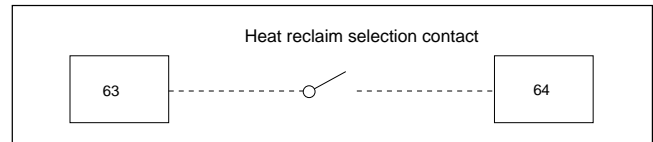

Key:
Contact open: condensing setpoint 1 / reclaim mode not selected
Contact closed: condensing setpoint 2 / reclaim mode selected

3.4.9 - Demand limit volt-free contact**

This contact is used to activate the demand limit function on the unit (see sections 4.2.10, 4.2.7 and 5.6). This contact is active whatever the operating type of the unit.

Connection for demand limit contact

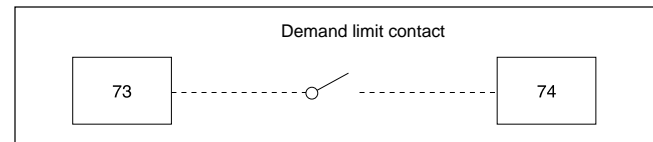

Key:
Contact open: demand limit disabled
Contact closed: demand limit active

3.4.10 - Evaporator water loop control and condenser water flow or thermostat box control volt-free contacts**

If these contacts open, the unit is shut down or prevented from restarting and an alarm is raised. They are used to control evaporator and condenser water flow on water-cooled units or to control the thermostat box temperature on air-cooled units.

Evaporator water-loop control contact connection

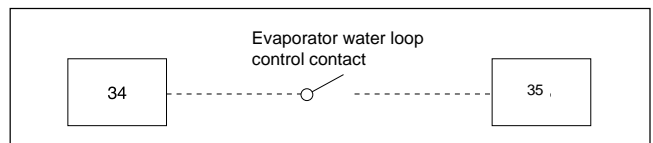

The evaporator water flow control contact is factory-wired (34-35). The evaporator pump must be controlled and connected between terminals 34 and 36.

Notes:

- * Each output (sections 3.4.1 to 3.4.4) can be supplied individually at 24 V a.c. - 0.5 A maximum, provided the total does not exceed 1 A.
- ** The volt-free contacts (sections 3.4.5 to 3.4.10) are internally supplied by electric boards under 24 V a.c. from 15 to 20 mA. The field-supplied volt-free contact must be compatible with these electrical specifications.

Condenser water flow/thermostat box control connection

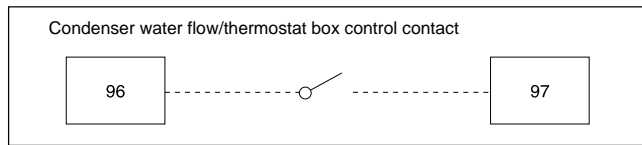

Heat reclaim condenser water flow control connection

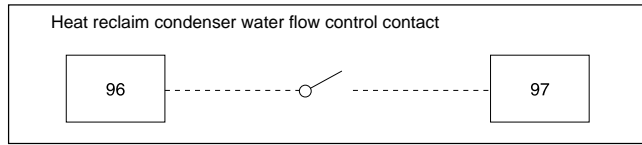

3.4.11 - 0-10 V d.c. input for setpoint reset or demand limit

This 0-10 V d.c. input is used either to reset the setpoint or limit demand on a unit (see configuration, section 4.2.10). This input is active whatever the operating type of the unit. This 0-10 V signal can be delivered by a customer-specific controller or by a 0-10 V temperature sensor.

0-10 Volt signal connection

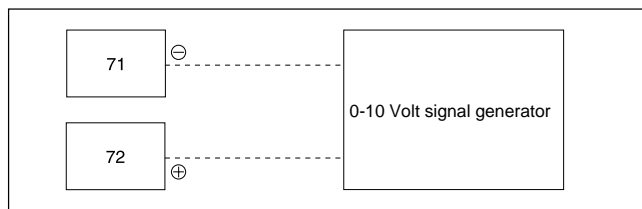

NOTE: Setpoint reset and demand limit based on an external 0-10 V d.c. signal cannot be used at the same time. Reset takes precedence over demand limit.

NOTE: If the source of the 0-10 V d.c. signal is a temperature sensor with a 24 V a.c. supply, it is essential to connect the power supply for this sensor to the earthed 24 V a.c. supply (wires 11-12) and not to the floating 24 V a.c. supply for the basic board.

3.4.12 - Condenser water valve control contacts

This output can be used on water-cooled units that have the condenser water valve control option installed. It delivers a 4-20 mA or 0-10 V d.c. signal, depending on the configuration (which must be carried out by Carrier Service).

Water valve connections

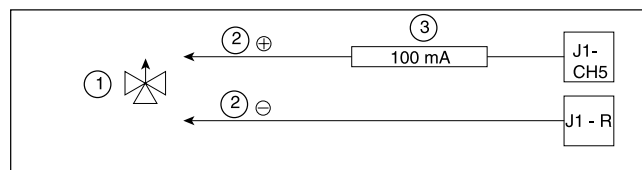

- 1 Condenser
- 2 Signal
- 3 Fuse

3.4.13 - 24 V a.c. contact

Terminals 11 and 12, located at the end of the customer terminal block, deliver an earthed 24 V a.c. with a maximum 1 A current.

Earthed 24 V a.c. output

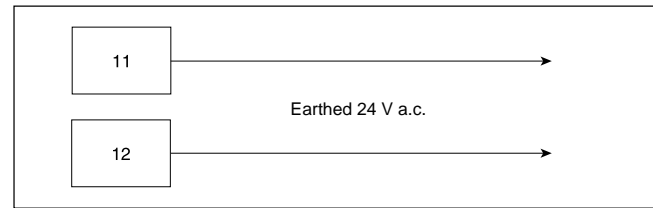

3.4.14 - Connection to the CCN

An RS485 bus is used for connection to the CCN. The CCN connector is located inside the control box on the right hand side of the customer terminal block. It is a three-pin connector:

- Pin 1: signal ⊕
- Pin 2: ground
- Pin 3: signal ⊖

3.4.15 - Heat reclaim condenser water valve connection

This output is used on air-cooled units with the heat reclaim option. It delivers a 4-20 mA or 0-10 V d.c. signal, depending on the configuration (which must be carried out by Carrier Service).

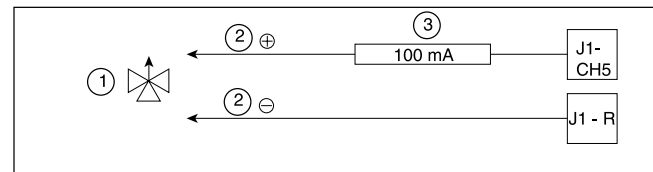

- 1 Condenser
- 2 Signal
- 3 Fuse

4 - SETTING UP PRO-DIALOG PLUS CONTROL

4.1 - General

The local interface enables a number of operating parameters to be displayed and modified.

The interface consists of two distinct parts:

The main interface (left hand section) gives access to all PRO-DIALOG Plus data and operating functions.

The summary interface (right hand section) gives quick access to just the main PRO-DIALOG Plus operating information.

4.2 - Main interface

4.2.1 - Description

The main interface gives access to the full array of operating parameters on the unit via 10 menus (represented by 10 icons). Each menu contains up to 20 items (numbered from 0 to 19).

The main interface consists of 4 functional blocks which are described below (the interface shown is for a dual-circuit air-cooled unit):

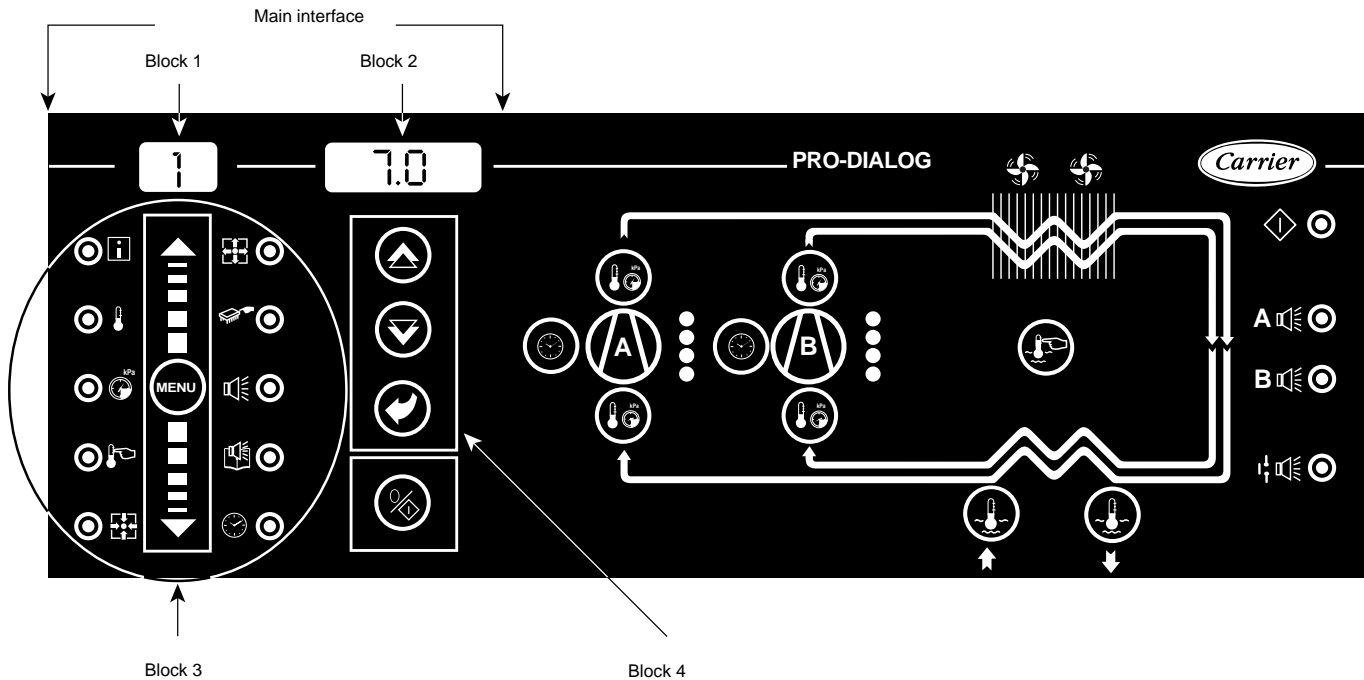

Block 1: A two-digit display showing the number of the item selected.

Block 2: A four-digit display showing the contents of the item selected.

Block 3: Consists of a MENU button, 10 LEDs and 10 icons indicating the menu selected.

Block 4: Consists of three selector buttons \uparrow , \downarrow , \updownarrow . Buttons \uparrow and \downarrow are used to scroll through the numbers of the menu items in block 2, or to increase or decrease the value of any modifiable parameter. The \updownarrow button gives access to the modification mode, or validates a modification.

The \square button is used to start/stop the chiller and modify its operating type.

4.2.2 - Operating types

4.2.2.1 - Description

The start/stop button on the chiller can be controlled by one of the following methods (control type):

- Locally on the actual unit (local control type)
- By remote control with the aid of user contacts (remote control type)
- By remote control with the aid of the CCN (CCN control type).

The main interface includes a \square button (called the operating type selector button) which can be used to select one of the above control types. In addition, when local control type is selected, this button can be used to select an operating type for the unit (e.g. second setpoint, cool, heat, etc.).

This combination of control types and modes that can be selected using the \square button is known as the Operating Types.

The Operating Type selector button can also be used locally to halt the unit or to activate one of the following operating types:

OPERATING TYPE	
Block 2 Display	Description
LOFF	Local Off: the unit is halted in local mode.
L-C1	Local operation - Local On - Cooling Setpoint 1: the unit is in local control mode and is authorised to start up in cooling mode with setpoint 1.
L-C2*	Local operation - Local On - Cooling Setpoint 2: the unit is in local control mode and is authorised to start up in cooling mode with setpoint 2. This is displayed if cooling setpoint 1 (item 0 in the setpoint menu) has a different value from cooling setpoint 2 (item 1 in the setpoint menu).
L-H*	Local operation - Local On - Heating Setpoint: the unit is in local control mode and is authorised to start up in heating mode (heat pump only).
LC1r*	Local operation - Local On - Cooling Setpoint 1 - Heat Reclaim: the unit is in local control mode and is authorised to start up in cooling mode with setpoint 1 and the reclaim mode is selected. This is not displayed if one of the following conditions is met: <ul style="list-style-type: none"> the unit is water-cooled and controls condenser water valves, and the condensing setpoint (item 3 in the setpoint menu) is equal to the reclaim setpoint (item 4 in the setpoint menu). the unit is air-cooled and the condensing setpoint (item 3 in the setpoint menu) is equal to the reclaim setpoint (item 4 in the setpoint menu).
LC2r*	Local operation - Local On - Cooling Setpoint 2 - Heat Reclaim: the unit is in local control mode and is authorised to start up in cooling mode with setpoint 2 and the reclaim mode is selected. This is displayed if LC1r is displayed and cooling setpoint 1 (item 0 in the setpoint menu) has a different value from cooling setpoint 2 (item 1 in the setpoint menu).
CCn	The unit is controlled by CCN commands.
rEM	The unit is controlled by external remote control contacts.

Key:

* : Displayed if the configuration requires it.

Section 5.1 gives a more detailed description of the commands to start/stop the unit, analysed by operating type.

4.2.2.2 - Stopping the unit in local mode

The unit can be stopped in local mode at any time by pressing the operating type selector button.

TO STOP THE UNIT			
Button	Action	Block 1 display	Block 2 display
	Press the operating type selector button for less than 4 seconds (one short press is enough)	C	LOFF
	When the button is released, the unit stops without the need for further action.	t	LOFF

4.2.2.3 - Modifying the operating type

The unit operating type can be modified at any time by the following method:

In the example that follows, the operating type to be selected is Local Operation - Cooling Setpoint 1 (L-C1).

CHANGING THE OPERATING TYPE			
Button	Action	Block 1 display	Block 2 display
	Press the operating type selector button for more than 4 seconds	C	LOFF
	Hold down the operating type selector button. The available operating types are displayed one by one until the button is released.		L-C1 L-C2 ↓ ↑ CCn
	Release the operating type selector button when the operating type you want is displayed (in this example L-C1). "C" flashes in block 1 to show that the controller is awaiting confirmation.		L-C1
	Press the button to confirm the operating type selected (in this example L-C1). "t" is displayed in block 1 to indicate the operating type selected. If the button is not pressed soon enough, the controller will cancel the change and continue to use the previous operating type.	t	L-C1

4.2.3 - Displaying/modifying a menu item

To access a menu item, first choose a menu. Each menu gives access to up to 20 items.

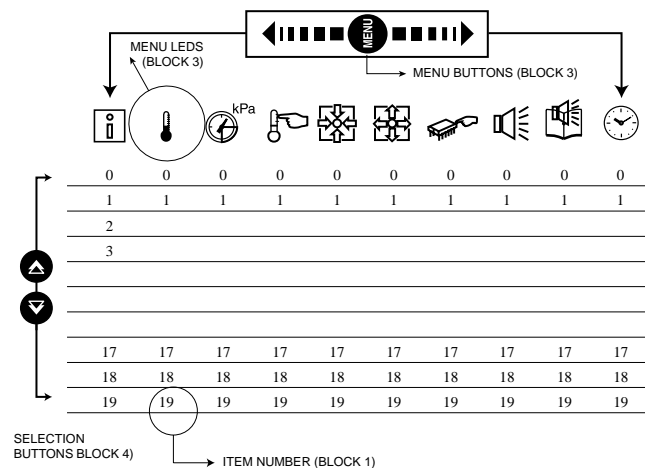





4.2.3.1 - Selecting a menu



The MENU button allows you to select a menu from the 10 that are available. Each time you press this button one of the 10 LEDs lights up in turn alongside each of the icons representing a menu. The active menu is the one against which the LED is lit.

	INFORMATION menu	Displays the general operating parameters for the unit.
	TEMPERATURE menu	Displays the unit operating temperatures.
	PRESSURE menu	Displays the unit operating pressures.
	SETPOINT menu	Displays the unit setpoints and enables them to be modified.
	INPUT menu	Displays the status of the unit digital and analogue inputs
	OUTPUT/TEST menu	Displays the status of the unit outputs and enables them to be tested.
	CONFIGURATION menu	Displays the unit configuration and enables it to be modified.
	ALARM menu	Displays active alarms.
	ALARM HISTORY menu	Displays the history of alarms.
	OPERATING LOG menu	Displays the operating times and number of starts for the unit and its compressors.

NOTE: To scroll quickly through the menus, hold the menu button down.









4.2.3.2 - Selecting a menu item

The  and  buttons let you scroll through the menu items. Menu item numbers are displayed in block 1. The item number increases or decreases every time you press the  or  button. The value or status associated with the active item is displayed in block 2.





To scroll quickly through the items, hold the  or  button down.



NOTE: Menu items that are not in use or incompatible with the configuration are not displayed.

The following example shows how to access item 3 in the Pressure menu.





















OPERATION	PRESS BUTTON	BLOCK 3 DISPLAY	BLOCK 1 DISPLAY
Press the MENU button until the LED marked PRESSURE lights.			0
			0
Press one of the arrow buttons until block 1 displays item number 3 (circuit B discharge pressure)			1
			2
			3

4.2.3.3 - Modifying the value of a parameter

Press the  button to change to modification mode. This lets you correct the value of an item with the aid of the  and  buttons (if you are allowed to overwrite the item concerned). When modification mode is activated, the LED for the menu to which the item belongs flashes in block 3. Once the required value is obtained, press the  button again to validate the change. The LED for the menu to which the item belongs then stops flashing in block 3, indicating that modification mode no longer applies.

In modification mode, the value to be modified increases or decreases in steps of 0.1 every time you press the  or  button. Holding one of these buttons down increases the rate of increase or decrease: after 2 seconds each step becomes 0.5, after 5 seconds the step becomes 1.0 and after 7 seconds the step becomes 2.0.

The following example shows how to modify the value of item 2 in the Setpoint menu.

OPERATION	PRESS BUTTON	BLOCK 3 LED	BLOCK 1 DISPLAY	BLOCK 2 DISPLAY
Hold down the MENU button until the LED for SETPOINT lights.			0	
			0	
Press one of the arrow buttons until block 1 displays item number 2 (cooling setpoint 2). The value for setpoint 2 is displayed in block 2 (6.0°C in this example)			1	6.0
Press the  button to enable the value associated with item 2 to be modified. The Setpoint menu LED flashes indicating that modification mode is active.			1	6.0
Keep pressing the  button until the value 5.6 is displayed in block 2. The Setpoint menu LED in block 3 keeps flashing.			1	5.9
			1	5.8
			1	5.7
			1	5.6
Press the  button again to validate the change. The new setpoint 2 is 5.6°C. The Setpoint menu LED in block 3 stops flashing, indicating that modification mode no longer applies.			1	5.6

ITEM	INFORMATION	TEMPERATURES	PRESSURES	SETPOINTS	INPUTS	OUTPUTS	CONFIGURATIONS	ALARMS	ALARMS HIST.	OPERATING LOG
0	Operating type	Evaporator water entering temperature	Circuit A discharge pressure	Cooling setpoint 1	Remote start/stop contact status	Compressor status	Password	Number of active alarms/resets	Historic alarm code 1**	Unit operating hours/10
1	Mode	Evaporator water leaving temperature	Circuit A suction pressure	Cooling setpoint 2	Remote setpoint contact status	Loader status	Master circuit select*	Active alarm code 1**	Historic alarm code 2**	Circuit A operating hours/10
2	Mode*	Copndenser water entering temperature*	Oil pressure A1*	Heating setpoint*	Remote heat/cool contact status*	Motor cooling valve status circuit A	Circuit loading sequence*	Active alarm code 2**	Historic alarm code 3**	Compressor A1 operating hours/10*
3	Mode*	Condenser water leaving temperature*	Oil pressure A2	Condensing setpoint*	Remote reclaim operat. contact status*	Motor cooling valve status circuit B	Delay at start-up in minutes	Active alarm code 3**	Historic alarm code 4**	Compressor A2 operating hours/10*
4	Mode*	Reclaim water entering temperature*	Oil differential pressure compressor A1*	Reclaim setpoint*	Capacity reduction contact status*	Oil solenoid status	Ramp loading selection	Active alarm code 4**	Historic alarm code 5**	Compressor B operating hours/10*
5	Mode*	Reclaim water leaving temperature*	Oil differential pressure compressor A2*	Capacity reduction setpoint as %	Evaporator water flow control contact	Oil heater status	Setpoint reset selection	Active alarm code 5**	Historic alarm code 6**	Compressor B1 operating hours/10*
6	Cooling/heating*	Saturated discharge temp. circuit A	Economizer pressure A1*	Cooling loading rate ramp	Condenser water flow control contact	Oil pimp status	Demand limit selection	-	Historic alarm code 7**	Compressor B2 operating hours/10*
7	Number of capacity stages	Saturated suction temp. circuit A	Economizer pressure A2*	Heating loading rate ramp*	Oil level circuit A	Fan status A1 - A2 - A3- A4	Software version number	-	Historic alarm code 8**	Number of units start-ups/10*
8	Present demand limit in %	Discharge gas pressure circuit A	Discharge pressure circuit B*	Cooling - 0-10 V d.c. signal for zero reset*	Oil level circuit B	Fan status B1 - B2 - B3 - B4*	ENO	-	Historic alarm code 9**	Number of compressor A1 start-ups/10*
9	Unit capacity in %	Discharge superheat, circuit A	Suction pressure circuit B*	Cooling - 0-10 V d.c. signal for full reset*	Water flow contr. contact heat reclaim condenser	Alarm circuit A and alarm circuit B status	BUS	-	Historic alarm code 10**	Number of compressor A2 start-ups/10*
10	Capacity circuit A	Motor temperature A1	Oil pressure B1*	Cooling - delta temperature for	Drain pressostat contact circuit A	Position EXV A in %*	-	-	-	Number of compressor A2 star-ups/10
11	Capacity circuit B in %*	Motor temperature A2	Oil pressure B2*	Cooling - delta temperature for full reset*	Drain pressostat contact circuit B	Position EXV B in %*	-	-	-	Number of compressor B1 start-ups/10*
12	Active setpoint	Saturated disch. temperature compressor B	Oil differential pressure compressor B1	Cooling - full reset degrees value*	Evaporator fluid level circuit A	Fan speed/ valve position circuit A in %*	-	-	-	Number of compressor B2 start-ups/10*
13	Control point	Saturated suction temperature Ciucuit B	Oil differential pressure compressor B2	Heating - 0-10 V d.c. signal for zero reset*	Evaporator fluid level circuit B	Fan speed circuit B in %*	-	-	-	Max. number of start-ups last hour
14	Active condensing setpoint*	Discharge temp. circuit B*	Economizer pressure B1*	Heating - 0-10 V d.c. signal for full reset*	0-10 V external signal	Evaporator and condenser pump status	-	-	-	Max. number of average start-ups last 24 hours
15	Capacity override	Discharge superheat, circuit B	Economizer pressure B2*	Heating - delta temperature for zero reset*	-	Evaporator and reclaim cond. heater status	-	-	-	-
16	EXV override	Motor temperature B1	-	Heating - delta temperature for zero reset*	-	Reclaim cond. water valve position in %	-	-	-	-
17	hr_status heat reclaim mode	Motor temperature B2	-	Heating - full reset degrees value*	-	Heat reclaim solenoid valve status	-	-	-	-
18	SMZ	Outdoor temperature	-	-	-	Local test interface	-	-	-	-
19	ZM	-	-	-	-	-	-	-	-	-

Key:

* Displayed if the configuration requires it.

** Displayed if the alarm exists.

- Not in use.

4.2.4 - Description of the INFORMATION menu

This menu is used to display the unit's main operating parameters.



ITEM	FORMAT	DESCRIPTION
0		Displays active operating type
	L-OFF	Local Off
	L-C1	Local On - Cooling setpoint 1
	L-C2	Local On - Cooling setpoint 1
	L-H	Local On - heating setpoint
	LC1r	Local On - Cooling setpoint 1 - Reclaim)
	LC2r	Local On - Cooling setpoint 2 - Reclaim)
	CCn	CCN Control
	rEM	Remote Control
1	n ₁ n ₂ n ₃ n ₄	Displays active modes: n ₁ n ₂ = 1st active mode n ₃ n ₄ = 2nd active mode
2***	n ₁ n ₂ n ₃ n ₄	Displays active modes: n ₁ n ₂ = 3rd active mode n ₃ n ₄ = 4th active mode
3***	n ₁ n ₂ n ₃ n ₄	Displays active modes: n ₁ n ₂ = 5th active mode n ₃ n ₄ = 6th active mode
4***	n ₁ n ₂ n ₃ n ₄	Displays active modes: n ₁ n ₂ = 7th active mode n ₃ n ₄ = 8th active mode
5***	n ₁ n ₂ n ₃ n ₄	Displays active modes: n ₁ n ₂ = 9th active mode n ₃ n ₄ = 10th active mode
6**	Cool Heat	Heating/cooling operation Cool/heat
7	nn	Number of active capacity stages
8**	nnn Inh	Present demand limit in % Demand limit disabled in Local operating type
9	nnn	Total active capacity of unit in %
10	nnn	Total active capacity of circuit A in %
11*	nnn	Total active capacity of circuit B in %
12	±nn.n	Active setpoint in °C
13**	±nnn	Control point in °C
14**	nn.n	Condensing or reclaim setpoint in °C
15	n ₁ n ₂	Reserved for use by Carrier Service only
16	n ₁ n ₂ n ₃ n ₄	Reserved for use by Carrier Service only
17	±nnn	Heat reclaim mode indicator, circuits A/B
18	n.n	Reserved for use by Carrier Service only
19	n.n	Reserved for use by Carrier Service only

Key:

n : numerical display

* : This item is displayed in certain unit configurations only.

** : Under certain operating conditions this item flashes (in block 1 of main interface).

*** : This item is not displayed when zero.

Item 0 Displays active operating type

This item displays the current operating type in text format.

Items 1-2-3-4-5 Displays active modes

Each of these items can display two active modes at the same time. The first two figures display one mode and the last two figures display another. These items enable up to 10 active modes to be displayed.

For example: 510 means that modes 5 and 10 are active. 11 means that mode 11 is active.

Description of modes:

MODE #	MODE NAME	DESCRIPTION
1	Local Off	The unit has stopped in local mode because operating type Local Off (LOFF) has been selected with the operating type selector button.
2	CCN Off	The unit has stopped in CCN mode because operating type CCN (CCn) has been selected with the operating type selector button and either: <ul style="list-style-type: none"> the unit has received a CCN halt command, or the controller has received a start command over the network but the start/stop remote control is authorised in CCN mode and the controller has received a halt command from a volt-free contact connected to the customer terminal block (see note, section 5.1).
3	Remote off	The unit has stopped in remote mode because operating type Remote Control (rEM) has been selected with the operating type selector button and the unit has received a shutdown command from volt-free contacts. See section 3.4.3, description of start/stop contact.
4	Local Operation	The unit is authorised to start up in local mode because operating mode Local Operation (L-C1 or L-C2 or L-H or LC1r or LC2r) has been selected with the operating type selector button.
5	CCN Operation	The unit is authorised to start up in CCN mode because operating type CCN (CCn) has been selected with the operating type selector button and the unit has received a CCN start command, and either: <ul style="list-style-type: none"> the start/stop remote control is not authorised in CCN mode, or the start/stop remote control is authorised in CCN mode and the controller has received a start command from a volt-free contact connected to the customer terminal block (see note, section 5.1).
6	Remote Operation	The unit is authorised to start up in remote mode because operating type Remote Control (rEM) has been selected with the operating type selector button and the unit has received a start command from volt-free contacts. See section 3.4.3, description of start/stop contact.
7	Delay at start-up active	The delay at start-up is active after the unit has been switched on or after the unit has been stopped. If the pause has not expired the mode is active. The delay can be configured in the configuration menu.
8	2nd cooling setpoint active	The second cooling setpoint is active because one of the following conditions has been met: <ul style="list-style-type: none"> Operating type Local Operation - Cooling Setpoint 2 (L-C2) has been selected; The unit is in operating type CCN (CCn) and has received a network command to use cooling setpoint 2; The unit is in operating type Remote (rEM) and cooling setpoint 2 has been selected with remote contacts. See section 3.4.4, description of setpoint selection contact.
9	Setpoint reset active	Setpoint reset is active. In this mode, the unit uses the reset function to adjust the leaving water temperature setpoint. Depending on the configuration, the setpoint can be reset by reference to: <ul style="list-style-type: none"> An external 0-10 V d.c. signal (supplied by customer or 0-10 V d.c. temperature sensor); The difference in temperature between water leaving and returning to the evaporator (cooling) or condenser (heating). For the reset function to be activated it must be configured (see section 4.2.10). Mode 9 is only active if the reset value calculated by the system is non-zero.
10	Demand limit active	Demand limit is active. In this mode, the demand at which the unit is authorised to operate is limited by reference to either: <ul style="list-style-type: none"> An external 0-10 V d.c. signal (supplied by customer) or A volt-free contact. For the demand limit function to be activated it must be configured (see section 4.2.10). Mode 10 is only active if the machine demands capacity greater than the limit value.
11	Ramp loading active	Ramp loading is active. In this mode, the rate of temperature drop (cooling mode) or rise (heating mode) in °C/min in the active heat exchanger leaving water is limited to a preset value in order to prevent compressor overload. The ramp values can be modified (see section 4.2.7).
12	Low temp. protection heating mode	The unit is in heating mode and the temperature of the evaporator leaving water is lower than the lesser of the two cooling setpoints. A capacity stage is removed. This mode only applies to heat pumps.
13 + 14	Low suction temperature protection	13 = circuit A & 14 = circuit B Protection for evaporator suction low temperature circuit is active. In this mode, circuit capacity is not authorised to rise if the unit is in cooling mode, and saturated suction temperature in the circuit is lower than the frost protection threshold.
15 + 16	Low discharge superheat protection	15 = circuit A & 16 = circuit B In this mode the circuit capacity is not authorised to rise.
17	High pressure protection circuit A	Circuit A is under high pressure protection because the HP protection threshold has been exceeded. Circuit capacity is not authorised to rise, and any slave compressors may be stopped in order to prevent a high pressure break.
18	High pressure protection circuit B	Circuit B is under high pressure protection because the HP protection threshold has been exceeded. Circuit capacity is not authorised to rise, and any slave compressors may be stopped in order to prevent a high pressure break.
19	Unit under SM control	Unit is under control of a System Manager (FSM or CSM III)
20	Master/slave link active	Unit is connected to a secondary unit by a master/slave link and either: <ul style="list-style-type: none"> The unit is configured as a master and this master is operating, or The unit is configured as a slave and the master is operating.
21 + 22	Liquid level reset circuit B	(21 = circuit A & 22 = circuit B) Active, if there is a large difference between leaving water temperature and SST

Item 6 Heating/cooling operation

This information is only available on units configured as heat pumps. This item shows the current operating mode.

The cooling mode is active in the following cases:

- The unit is in operating type Local Cooling (L-C1 or LC2).
- The unit is in operating type CCN (CCn) and has received a cooling operation network command.
- The unit is in operating type Remote (rEM) and has received a cooling operation command from a remote contact (see section 3.4.5, description of remote heat/cool contact).

The heating mode is active in the following cases:

- The unit is in operating type Local Heating (L-H).
- The unit is in operating type CCN (CCn) and has received a heating operation network command.
- The unit is in operating type Remote (rEM) and has received a heating operation command from a remote contact (see section 3.4.5, description of remote heat/cool contact).

Item 7 Number of active capacity stages

This is the number of capacity stages operating.

Item 8 Demand limit active

This is the authorised operating capacity of the unit. The value depends on the limitation method used (see section 4.2.10):

- based on an external 0-10 V d.c. signal;
- based on the limit setpoint and the status of a remote contact.

Disablement of demand limit in local mode: when the unit is in **local** operating mode it is possible to disable demand limit from any source, via the keyboard. For this purpose, follow the procedure described below.

OPERATION	PRESS BUTTON	BLOCK 3 LED	BLOCK 1 DISPLAY	BLOCK 2 DISPLAY
Hold down the MENU button until the LED for INFORMATION lights.			0	
Press one of the arrow buttons until block 1 displays item number 8 (demand limit). The active demand limit value is displayed in block 2 (75% in this example).			1	
			8	75
Press the button. The INFORMATION menu LED flashes indicating that modification mode is active.			8	75
Press the or button. "InH" is displayed in block 2. The INFORMATION menu LED in block 3 keeps flashing.			8	InH
Press the button again. Demand limit is now disabled. The INFORMATION menu LED stops flashing.			8	InH

The procedure for cancelling demand limit disablement in local mode is exactly as described above. When the setpoint LED flashes, press the procedure for cancelling demand limit disablement in local mode is exactly as described above. When the setpoint LED flashes, press the or button. This cancels the "InH" display and restores reduction. Then press the button.

Item 9 Total active capacity of unit as %

This is the percentage of compressor capacity used by the unit.

Item 10-11 Total active capacity of circuits A/B as %

This is the percentage of compressor capacity used on circuits A/B.

Item 12 Active setpoint

This is the current heating or cooling setpoint.

It refers to cooling setpoint 1 in the following cases:

- The unit is in operating type Local Operation - Cooling Setpoint 1 (L-C1 or LC1r).
- The unit is in operating type CCN (CCn) and cooling mode, and has received a network command to use setpoint 1.
- The unit is in operating type Remote (rEM) and has received a command to operate in cooling type and to use setpoint 1, from a remote contact (see section 3.4.4, description of remote cooling setpoint selection contact).

It refers to cooling setpoint 2 in the following cases:

- The unit is in operating type Local Operation - Cooling Setpoint 2 (L-C2 or LC2r).
- The unit is in operating type CCN (CCn) and cooling mode, and has received a network command to use setpoint 2.
- The unit is in operating type Remote (rEM) and has received a command to operate in cooling mode and to use setpoint 2, from a remote contact (see section 3.4.4, description of remote cooling setpoint selection contact).

Cooling setpoint 2 is normally used for ice storage.

It refers to heating setpoint in the following cases:

- The unit is in operating type Local Operation - Heating Setpoint (L-H).
- The unit is in operating type CCN (CCn) and heating mode.
- The unit is in operating type Remote (rEM) and has received a command to operate in heating mode.

NOTE: The setpoint selection contact may in exceptional cases be configured as active (configuration by Carrier Service) if the unit operates in CCN mode as part of a master-slave link (see section 5.18).

Item 13

Control point

This is the setpoint used by the controller to adjust the temperature of leaving water. Control point = active setpoint + reset. The reset is generally positive in cooling mode and negative in heating mode. See section 4.2.7, calculating the reset.

Item number 13 flashes (in block 1 of the user interface) when the unit is in CCN operating type and the control point is forced by the CCN.

Item 14

Condensing setpoint

This is the setpoint used by the controller to adjust the condensing or reclaim temperature.

It refers to the normal condensing setpoint in the following cases:

- The unit is in operating type Local Operation - Cooling Setpoint 1 (L-C1 or LC2).
- The unit is in operating type CCN (CCn) and cooling mode, and is under network command for normal mode (no reclaim).
- The unit is in operating type Remote (rEM) and has received a command to operate in cooling mode and normal condensing type (no reclaim), from a remote contact (see section 3.4.6, description of remote contact).

It refers to the reclaim setpoint in the following cases:

- The unit is in operating type Local - Cooling Setpoint 1 (LC1r or LC2r).
- The unit is in operating type CCN (CCn) and cooling mode, and is under network command for reclaim mode.
- The unit is in operating type Remote (rEM) and has received a command to operate in cooling mode and reclaim condensing mode, from a remote contact (see section 3.4.6, description of remote contact).

The number for item 14 flashes (in block 1 of the user interface) when the unit is in CCN operating mode and the condensation value is forced by the CCN.

Item 15-16-18-19 Reserved for use by Carrier Service only

Item 17

Heat reclaim mode indicator, circuits A/B (see section 5.20)

4.2.5 - Description of the TEMPERATURES menu

This menu displays the unit operating temperatures. All temperatures are displayed in degrees Celsius. Access to this menu is read-only.



ITEM	FORMAT	DESCRIPTION
0	±nn.n	Evaporator entering water temperature
1	±nn.n	Evaporator leaving water temperature
2*	±nn.n	Condenser entering water temperature (if used)
3*	±nn.n	Condenser leaving water temperature (if used)
4*	±nn.n	Reclaim condenser entering water temperature (if used)
5*	±nn.n	Reclaim condenser leaving water temperature (if used)
6	±nn.n	Saturated condensing temperature circuit A
7	±nn.n	Saturated suction temperature circuit A
8*	±nn.n	Discharge gas temperature circuit A
9*	±nn.n	Discharge superheat temperature circuit A
10*	±nn.n	Motor temperature A1
11*	±nn.n	Motor temperature A2
12*	±nn.n	Saturated condensing temperature circuit B
13*	±nn.n	Saturated suction temperature circuit B
14*	±nn.n	Discharge gas temperature circuit B
15	±nn.n	Superheat temperature circuit B
16	±nn.n	Motor temperature B1
17*	±nn.n	Motor temperature B2
18	±nn.n	Outdoor temperature

Key:

n : numerical display

* : This item is displayed in certain unit configurations only.

Item 18

Outdoor temperature

This item displays the outdoor temperature if an outdoor temperature sensor is connected to the 0-10 V d.c. analogue input on the customer terminal block and if that sensor has been calibrated (by Carrier Service). If it has not been calibrated, the value displayed is the value of the incoming 0-10 V d.c. signal.

4.2.6 - Description of the PRESSURE menu

This menu displays the unit operating pressures. All pressures are relative, and are expressed in kPa. Access to this menu is read-only.



ITEM	FORMAT	DESCRIPTION
0	nnnn	Discharge pressure circuit A
1	nnnn	Suction pressure circuit A
2	±nnn	Oil pressure compressor A1
3*	±nnn	Oil pressure compressor A2
4	±nnn	Differential oil pressure compressor A1
5*	±nnn	Differential oil pressure compressor A2
6	±nnn	Economizer pressure A1
7*	±nnn	Economizer pressure A2
8	nnnn	Discharge pressure circuit B
9	nnnn	Suction pressure circuit B
10	±nnn	Oil pressure compressor B1
11*	±nnn	Oil pressure compressor B2
12	±nnn	Differential oil pressure compressor B1
13*	±nnn	Differential oil pressure compressor B2
14	±nnn	Economizer pressure B1
15*	±nnn	Economizer pressure B2

Key:

n : numerical display

* : This item is displayed in certain unit configurations only.

4.2.7 - SETPOINT menu

This menu displays the unit setpoints. These points can be modified when the unit is in Local operating mode.



ITEM	FORMAT	DESCRIPTION
0	±nn.n	Cooling setpoint 1 in °C
1	±nn.n	Cooling setpoint 2 in °C
2*	nn.n	Heating setpoint in °C. Heat pump only.
3*	nn.n	Condensing setpoint 1 in °C.
4*	nn.n	Condensing or reclaim setpoint 2 in °C.
5	nnn	Demand limit as %
6*	n.n	Cooling mode ramp in °C/minute
7*	n.n	Heating mode ramp in °C/minute. Heat pump only.
8*	nn.n	Voltage reset 0-10 V d.c. cooling mode - Voltage for zero reset
9*	nn.n	Voltage reset 0-10 V d.c. cooling mode - Voltage for max. reset
10*	±nn.n	Delta T reset cooling - Delta T for zero reset
11*	±nn.n	Delta T reset cooling - Delta T for maximum reset
12*	±nn.n	Cooling reset - Maximum reset value in °C
13*	nn.n	Voltage reset 0-10 V d.c. heating mode - Voltage for zero reset
14*	nn.n	Voltage reset 0-10 V d.c. heating mode - Voltage for max. reset
15*	±nn.n	Delta T reset heating - Delta T for zero reset
16*	±nn.n	Delta T reset heating - Delta T for maximum reset
17*	±nn.n	Heating reset - Maximum reset value in °C

Key:

n : numerical display

* : This item is displayed in certain unit configurations only.

Items 0-1

Cooling setpoint 1 & 2

This item lets you display and modify the cooling setpoints. Cooling setpoint 2 is generally used for ice storage.

See section 4.2.4, description of item 10 (active setpoint) and the conditions of use for setpoints 1 and 2.

Item 2

Heating setpoint

This item is used for heat pumps only. It can be used to display and modify the heating setpoint.

See section 4.2.4, description of item 10 (active setpoint) and the conditions of use for the heating setpoint.

Limiting values for the cooling and heating setpoints

SET POINT	°F	°C
Minimum cooling value		
• Water	38	3,3
• Medium brine (low temperature)	14	-10
• Low brine (very low temperature)	-4	-20
Maximum cooling value	101	38,3
Maximum heating value	138	58,8
Minimum heating value	80	26,6

Item 3

Condensing setpoint

This item is used to display and modify the condensing setpoint. It is used by the system to control the fan stages or a variable speed fan (air-cooled unit) or to control condenser water valves (water-cooled unit) when the unit is not in reclaim mode (see section 4.2.4, item 14, the conditions of use for the normal condensing setpoint).

Item 4

Reclaim setpoint

This item is used to display and modify the reclaim setpoint. As in item 3, it is used to control condensation.

Limiting values for the condensing setpoints

CONDENSING SETPOINT	°F (psig)	°C (kPa)
Minimum temperature (corresponding pressure)	96 (114)	35 (788)
Maximum temperature (corresponding pressure)	140 (229)	60 (1558)

Item 5

Demand limit setpoint

This item is used to define the maximum capacity that the unit is authorised to put into operation when the demand limit contact is closed and if reduction by contact has been selected (see section 3.4.7, description of contact, and section 4.2.10, configuring the demand limit method).

Range: 0 to 100 %

Items 6-7

Cooling/heating mode ramp

These items refer to the rates of temperature drop (cooling mode) or temperature rise (heating mode) in °C/minute in the active heat exchanger leaving water. These parameters are only accessible if the ramp function is validated in the configuration menu (see section 4.2.10). When the capacity loading of the unit is effectively limited by the ramp, mode 11 is displayed in the information menu (see section 4.2.4).

Range: 0.1 to 1.1°C/min

Items 8 to 17

Setpoint reset

In normal operating conditions, the unit maintains a leaving water temperature at the heat exchanger (i.e. evaporator in cooling mode or condenser in heating mode) which is more or less equal to the active cooling or heating setpoint. This setpoint is generally chosen by reference to full load operating conditions. Under partial load, it may be necessary to reset the setpoint upwards (in cooling mode) or downwards (in heating mode) in order to optimise the unit performance.

The system uses the control point to adjust the water leaving temperature:

- Control point = active setpoint + reset (cooling mode)
- Control point = active setpoint - reset (heating mode)

When the reset function is active (i.e. when the calculated reset value is non-zero) mode 9 is displayed (see section 4.2.4).

Items 8-9-12 Voltage reset - Cooling mode values
Items 13-14-17 Voltage reset - Heating mode values

This function is only active when reset based on an external 0-10 V d.c. signal has been selected (see section 4.2.10).

Voltage reset is based on an external 0-10 V d.c. signal applied to specific inputs on the customer terminal block (see section 3.4.10). The source of this signal is usually a 0-10 V d.c. external ambient or air temperature probe which gives a measure of the load trends for the building. If this is the case, the reset parameters are generally configured to deliver the following:

- In cooling mode, an reset with a negative slope. The controller automatically resets the chilled water setpoint upwards in response to a drop in the outside or ambient temperature.
- In heating mode, an reset with a positive slope. The controller automatically resets the chilled water setpoint downwards in response to a rise in the outside or ambient temperature.

However, the reset parameters remain accessible to any type of configuration and make it possible to obtain any combination of slope and reset origin in response to the 0-10 V d.c. input signal.

Voltage reset is a linear function which requires three parameters to be configured:

- A 0-10 V d.c. reference value at which the reset is zero: this is the “*voltage for zero reset*” (item 8 for cooling mode - item 13 for heating mode).
- A 0-10 V d.c. reference value at which the reset is at maximum: this is the “*voltage for maximum reset*” (item 9 for cooling mode - item 14 for heating mode).
- The maximum reset value: this is the “*maximum reset value*” (item 12 for cooling mode - item 17 for heating mode).

Range: Voltage for zero reset:
0 to 10 volts

Voltage for maximum reset:
0 to 10 volts

Maximum reset value:
-16.6 to 16.6°C

The reset is calculated as follows if the value of the “*Voltage for zero reset*” exceeds the value of the “*Voltage for maximum reset*”:

- The reset is zero if the external 0-10 V d.c. reset signal exceeds the reference value “*Voltage for zero reset*”.
- The reset equals the maximum reset value if the external 0-10 V d.c. reset signal is lower than the reference value “*Voltage for maximum reset*”.
- If the 0-10 V d.c. reset signal is between the reference values “*Voltage for zero reset*” and “*Voltage for maximum reset*”, the reset value is calculated by linear interpolation between the “*Maximum reset*” value and 0.

The reset is calculated as follows if the value of the “*Voltage for zero reset*” is lower than the value of the “*Voltage for maximum reset*”:

- The reset is zero if the external 0-10 V d.c. reset signal is lower than the reference value “*Voltage for zero reset*”.
- The reset equals the “*Maximum reset value*” if the external 0-10 V d.c. reset signal exceeds the reference value “*Voltage for maximum reset*”.
- If the 0-10 V d.c. reset signal is between the reference values “*Voltage for zero reset*” and “*Voltage for maximum reset*”, the reset value is calculated by linear interpolation between 0 and the “*Maximum reset*” value.

Sample voltage reset configuration:

In this example, the cooling setpoint starts to be reset with effect from 6.6 V d.c. (full load) up to a maximum reset of 3°C at 5.0 V d.c.

This example assumes that the:

- Voltage reset has already been configured in the configuration menu (see section 4.2.10, configuration).

The configuration shall be as follows:

- Zero reset if the external signal (“*Voltage for zero reset*” - Item 8) is greater than 6.6 volts;
- Maximum reset 3°C (Maximum reset value - Item 12) if the external signal (“*Voltage for maximum reset*” - Item 9) is lower than 5.0 volts.

OPERATION	PRESS KEY	BLOCK 3 LED	BLOCK 1 DISPLAY	BLOCK 2 DISPLAY
Hold down the MENU button until the LED for SETPOINT lights.			0	
			0	
Press \downarrow or \uparrow until block 1 displays item number 8; this item shows the zero reset voltage in cooling mode. The default value (0 volts) is displayed in block 2.	\downarrow		0 1	
	\downarrow		8	0.0
Press the \rightarrow button to authorise modification of the value associated with item 8. The SETPOINT menu LED flashes indicating that modification mode is active and the value can be modified.	\rightarrow		8	0.0
Press the \downarrow until the value 6.6 is displayed in block 2. The SETPOINT menu LED in block 3 keeps flashing.	\downarrow		8	0.1
	\downarrow		8	6.6
Press the \rightarrow button again to validate the change. The new value for item 8 is 6.6 volts. The SETPOINT menu LED stops flashing, indicating that modification mode no longer applies.	\rightarrow		8	6.6
Press \downarrow until block 1 displays item number 9; this item shows the maximum reset voltage in cooling mode. The default value (0 volts) is displayed in block 2.	\downarrow		9	0.0
Press the \rightarrow button to authorise modification of the value associated with item 9. The SETPOINT menu LED flashes indicating that modification mode is active and the value can be modified.	\rightarrow		9	0.0
Press \downarrow until the value 5.0 is displayed in block 2. The SETPOINT menu LED in block 3 keeps flashing.	\downarrow		9	0.1
	\downarrow		9	5.0
Press the \rightarrow button again to validate the change. The new value for item 9 is 5.0 volts. The SETPOINT menu LED stops flashing, indicating that modification mode no longer applies.	\rightarrow		9	5.0
Press \downarrow until block 1 displays item number 12; this item shows the maximum reset value in cooling mode. The default value (0°C) is displayed in block 2.	\downarrow		9	5.0
	\downarrow		12	0.0
Press the \rightarrow button to authorise modification of the value associated with item 12. The SETPOINT menu LED flashes indicating that modification mode is active and the value can be modified.	\rightarrow		12	0.0
Press \downarrow until the value 3.0 is displayed in block 2. The SETPOINT menu LED in block 3 keeps flashing.	\downarrow		12	0.1
	\downarrow		12	3.0
Press the \rightarrow button again to validate the change. The new value for item 12 is 3.0°C. The SETPOINT menu LED stops flashing, indicating that modification mode no longer applies.	\rightarrow		12	3.0

Let us assume that the 0-10 V d.c signal comes from a calibrated outside temperature probe (configuration accessible to Carrier Service only) with the following parameters:

- The probe delivers 0 volts at -20°C.
 - The probe delivers 10 volts at 40°C.
- Based on this information:
- The probe delivers 5.0 volts at 10°C.
 - The probe delivers 6.6 volts at 20°C.

The active cooling setpoint reset curve is then as follows:

Cooling setpoint voltage reset

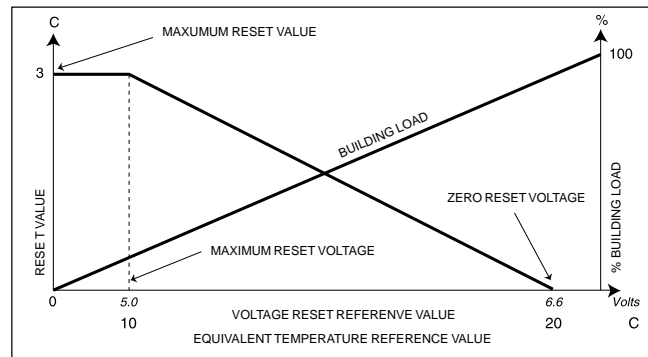

Items 10-11-12 ΔT reset - Cooling mode reset values
Items 15-16-17 ΔT reset - Heating mode reset values

This function is only active if an reset based on water returning to the evaporator (cooling mode) or condenser (heating mode) has been selected (see section 4.2.10). In the following description, ' ΔT ' represents the temperature difference between water entering and leaving the evaporator in cooling mode or the condenser in heating mode.

Since the difference between the leaving water temperature and the return water temperature is a measure of the building load, a setpoint reset based on the return water temperature is actually an reset method based on the average building load. As the building load falls from 100% to 0%, so the entering evaporator water temperature falls in proportion to the load. Thus a drop in temperature in the evaporator which is in general 5.5°C at full load would theoretic-ally become 0°C at zero load. In this event, the reset parameters are generally configured to deliver an reset with a negative slope:

- In cooling mode, the controller automatically resets the chilled water setpoint upwards in response to a drop in ΔT .
- In heating mode, the controller automatically resets the chilled water setpoint downwards in response to a rise in ΔT .

However, the reset parameters remain accessible to any type of configuration and make it possible to obtain any combination of slope and reset origin in response to fluctuations in the value of ΔT on the active heat exchanger.

Reset based on ΔT is a linear function which requires three parameters to be configured:

- A reference ΔT at which the reset is zero: this is the ΔT for zero reset referred to in item 10 for cooling mode or item 15 for heating mode.
- A reference ΔT at which the reset is at maximum: this is the ΔT for maximum reset referred to in item 11 for cooling mode or item 16 for heating mode.
- The maximum reset value: this is the maximum reset value referred to in item 12 for cooling mode - item 17 for heating mode.

Range: ΔT for zero reset:
0 to 13.8°C
 ΔT for maximum reset:
0 to 13.8°C
Maximum reset value:
-16.6 to 16.6°C

The reset is calculated as follows if the value of the ΔT for zero reset exceeds the value of the ΔT for maximum reset (negative slope):

- The reset is zero if the current ΔT exceeds the reference value ΔT for zero reset.
- The reset equals the maximum reset value if the current ΔT is lower than the reference value ΔT for maximum reset.
- If the current ΔT is between the reference values ΔT for zero reset and ΔT for maximum reset, the reset value is calculated by linear interpolation between the maximum reset value and 0.

The reset is calculated as follows if the value of the ΔT for zero reset is lower than the value of the ΔT for maximum reset (positive slope):

- The reset is zero if the current ΔT is lower than the reference value ΔT for zero reset.
- The reset equals the maximum reset value if the current ΔT exceeds the reference value ΔT for maximum reset.
- If the current ΔT is between the reference values ΔT for zero reset and ΔT for maximum reset, the reset value is calculated by linear interpolation between 0 and the maximum reset value.

Sample ΔT reset configuration:

In this example, the cooling setpoint starts to be reset with effect from a ΔT at the evaporator of 5.0°C (full load) up to a maximum reset of 3°C at a ΔT of 3.0°C.

This example assumes that the:

- Reset based on ΔT has already been configured in the configuration menu (see section 4.2.10, configuration).

The configuration shall be as follows:

- Zero reset if the evaporator ΔT (i.e. ΔT for zero reset - Item 10) is greater than 5.0°C;
- Maximum reset 3°C (Maximum reset value - Item 12) if the evaporator ΔT (i.e. ΔT for maximum reset - Item 11) is lower than 3.0°C.

The setpoint curve is then as follows:

Cooling setpoint ΔT reset

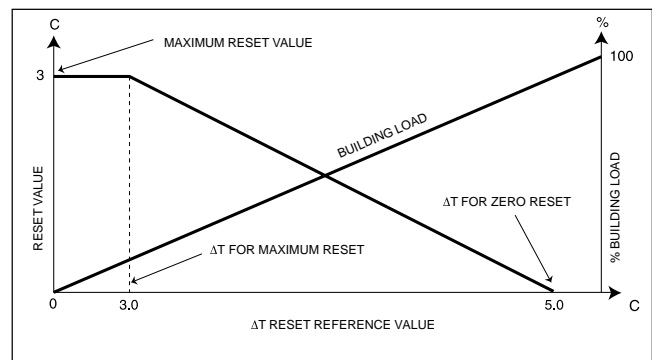

4.2.8 - Description of the INPUT menu

This menu displays the status of the controller inputs. Access to this menu is read-only.



ITEM	FORMAT	DESCRIPTION
0	open/close	Remote start/stop contact status
1	open/close	Remote cooling setpoint selection contact status
2*	open/close	Remote heat/cool selection contact status
3*	open/close	Remote reclaim mode selection contact status
4	open/close	Demand limit contact status
5	open/close	Evaporator water flow control contact status
6	open/close	Condenser water flow control contact status
7	open/close	Oil level control contact status circuit A
8	open/close	Oil level control contact status circuit B
9	nn	Heat reclaim condenser water flow control contact status
10	nn	Drain pressostat contact status, circuit A
11	nn	Drain pressostat contact status, circuit B
12	nn	Evaporator liquid refrigerant level circuit A
13	nn	Evaporator liquid refrigerant level circuit B
14	nnn	0-10 V d.c signal

Key:

* : This item is displayed in certain unit configurations only.

Item 0 Remote start/stop contact status
This contact is used to select the following modes of operation when the unit is in remote operating type (rEM):

- Contact open: unit stop command
- Contact closed: unit authorised to start up.

See section 3.4.5 for a description of the connections for the remote start/stop contact.

Item 1 Remote cooling setpoint selection contact status
This contact is used to select a cooling setpoint only when the unit is in cooling mode and remote operating type (rEM):

- Contact open: unit using cooling setpoint 1
- Contact closed: unit using cooling setpoint 2

This command is inactive if the unit is operating in heating mode.

See section 3.4.6 for a description of the connections for the remote cooling setpoint selection contact.

Item 2 Remote heat/cool selection contact status
This contact is used to select heating or cooling mode only when the unit is in remote operating type (rEM):

- Contact open: unit in cooling mode
- Contact closed: unit in heating mode

This command applies to heat pumps only.

See section 3.4.7 for a description of the connections for the remote heat/cool selection contact.

Item 3 Remote reclaim mode selection contact status
This contact is used to select the second condensing setpoint or reclaim mode (provided the unit is of the reclaim type) only when the unit is in cooling mode and remote operating type (rEM):

- Contact open: unit using normal condensing setpoint and in normal mode (no reclaim).
- Contact closed: unit using reclaim setpoint and in reclaim mode.

See section 3.4.8 for a description of the connections for the remote condensation mode selection contact.

Item 4 Demand limit contact status
When closed this contact limits the demand of the unit by reference to the value of the demand limit setpoint, if the contact method of demand limit has been selected (see section 4.2.10).

- Contact open: unit demand not limited
- Contact closed: unit demand limited to the limit setting.

See section 4.2.7 for a description of demand limit setting and section 3.4.9 for a description of reduction contact connections.

NOTE: This contact is active in all operating types.

Item 5 Interlock check contact status
When this contact opens the unit stops or is prevented from starting and an alarm is created. In general the contact is used to control the evaporator water flow.

See section 3.4.8 for a description of the connection for the lockout contact.

NOTE: This contact is active in all operating types.

Item 14 External 0-10 V d.c. signal
This signal, which is from an external source, can be used (depending on the configuration) for:

- The reset function
- Demand limit of the unit

See section 4.2.10 for the configuration of the signal. See section 3.4.10 for a description of the connection for the 0-10 V d.c. signal.

NOTE: This contact is active in all operating types.

4.2.9 - Description of the OUTPUT/TEST menu

4.2.9.1 - General

This menu displays the status of the controller outputs. When the machine is **fully stopped** (LOFF) the outputs can be actioned for tests.



ITEM	FORMAT	DESCRIPTION
0	b ₁ b ₂ b ₃ b ₄	Status of non accessible compressors in test mode b ₁ : Compressor A1 b ₂ : Compressor A2 b ₃ : Compressor B1 b ₄ : Compressor B2
1*	b ₁ b ₂ b ₃ b ₄	Status of loaders b ₁ : Loader 1 circuit A b ₂ : Loader 2 circuit A b ₃ : Loader 1 circuit B b ₄ : Loader 2 circuit B
2*	b ₁ b ₂ b ₃ b ₄	Motor cooling valve status circuit A b ₁ : Main valve compressor A1 b ₂ : Additional valve compressor A1 b ₃ : Main valve compressor A2 b ₄ : Additional valve compressor A2
3	b ₁ b ₂ b ₃ b ₄	Motor cooling valve status circuit B b ₁ : Main valve compressor B1 b ₂ : Additional valve compressor B1 b ₃ : Main valve compressor B2 b ₄ : Additional valve compressor B2
4	b ₁ b ₂ b ₃ b ₄	Oil solenoid valve status b ₁ : Oil solenoid valve compressor A1 b ₂ : Oil solenoid valve compressor A2 b ₃ : Oil solenoid valve compressor B1 b ₄ : Oil solenoid valve compressor B2
5	b ₁ b ₂	Oil heater status b ₁ : Oil heater circuit A b ₂ : Oil heater circuit B
6	b ₁ b ₂	Oil pump status b ₁ : Oil pump circuit A b ₂ : Oil pump circuit B
7	b ₁ b ₂ b ₃ b ₄	Fan stages status circuit A b ₁ : Fan stage 1 b ₂ : Fan stage 2 b ₃ : Fan stage 3 b ₄ : Fan stage 4
8	b ₁ b ₂ b ₃ b ₄	Fan stages status circuit B b ₁ : Fan stage 1 b ₂ : Fan stage 2 b ₃ : Fan stage 3 b ₄ : Fan stage 4
9	b ₁ b ₂	Alarm outputs status b ₁ : Circuit A b ₂ : Circuit B
10*	nnn	EXV position circuit A
11*	nnn	EXV position circuit B
12*	nnn	Variable fan speed or condenser water valve position as % - Circuit A
13	nnn	Variable fan speed as % - Circuit B
14	b ₁ b ₂	Evaporator and condenser pump status
15	b ₁ b ₂	Evaporator and heat reclaim condenser heater status b ₁ : Evaporator heater b ₂ : Heat reclaim condenser heater
16	nnn	Heat reclaim condenser water valve position in %
17	b ₁ b ₂ b ₃ b ₄	Heat reclaim mode solenoid valve status b ₁ : Heat reclaim coil shutoff solenoid valve, circuit A b ₂ : Heat reclaim coil drain solenoid valve, circuit A b ₃ : Heat reclaim coil shutoff solenoid valve, circuit B b ₄ : Heat reclaim coil drain solenoid valve, circuit B
18	n	Local interface test

Key:

* : This item is displayed in certain unit configurations only.
b : 0 = Open/Closed; 1 = Start/Stop
n : numerical display

Access to the tests is password controlled. The password must first have been entered in the Configuration menu (see section 4.2.10).

To carry out a test use the or buttons to access the output to be tested and press the A button to activate modification mode. The Output/Test LED on the user interface starts to flash. Enter the required test value and press to start the test. The Output/Test LED stops flashing. Press , or to stop the test.

Item 1

Status/Test of loaders

These items display the status of the compressors on circuit A or B. They can also test them independently.

For example:

Test of loader 2 circuit A and loader 1 circuit B. The password must already have been entered in the Configuration menu. If not, the message “no” will be displayed in block 2 (see section 4.2.10).

OPERATION	PRESS KEY	BLOCK 3 LED	BLOCK 1 DISPLAY	BLOCK 2 DISPLAY
Hold down the MENU button until the LED for OUTPUTS/TESTS lights.			0	"no"
Press the button to go to item loader.			0	
Press the button to authorise modification of the value associated with item 1. The OUTPUTS/TESTS menu LED flashes to show that modification mode is active and the value can be modified.			1	0001
Press until the value 0100 is displayed in block 2. The LED for OUTPUTS/TESTS in block 3 keeps flashing to show that modification mode is active.			1	0100
Press the button again. Loader 2 of circuit A starts and the LED for OUTPUTS/TESTS in block 3 stops flashing.			1	0100
Press the button again. Loader 2 of circuit A stops and the LED for OUTPUTS/TESTS in block 3 starts flashing again.			1	0001
Press until the value 0010 is displayed in block 2. The LED for OUTPUTS/TESTS in block 3 keeps flashing.			1	0010
Press the button to start loader 1 of circuit B. The LED for OUTPUTS/TESTS in block 3 stops flashing.			1	0010

4.2.9.2 - Outputs other than loaders

The test procedure is as described above.

Item 2*

Status/test motor cooling valves circuit A

Item 3*

Status/test motor cooling valves circuit B

Item 4*

Status/test oil solenoid valves circuits A + B

Item 5*

Status/test oil heater outputs circuits A + B

Item 6*

Status/test oil pump outputs circuits A + B

Item 7

Fan stages status/test circuit A

Item 8

Fan stages status/test circuit B

In test mode, the or buttons in block 4 display 0001, 0010, 0100 and 1000 in succession, so as to force the various fan stages in turn on each circuit. These items only apply to air-cooled units.

Item 9

Alarm output status/test - Circuits A & B

In test mode, the or buttons in block 4 display 01, and 10 in succession, so as to force each alarm output status in turn on each circuit.

- Item 10** **EXV status/test - Circuit A**
Item 11 **EXV status/test - Circuit B**
 In test mode, the direction arrows display “OPEN” so as to force the valve to its maximum open position.
- Item 12** **Variable speed fan or condenser water valve status/test - Circuit A**
- Item 13** **Variable speed fan status/test - Circuit B**
 In test mode, each element can be tested at a value in the range 0 to 100%. Item 13 is not applicable to air-cooled units.
- Item 14**** **Evaporator and condenser water pump status/test**
- Item 15*** **Evaporator and heat reclaim condenser heater status/test**
- Item 16** **Heat reclaim condenser water valve output status/test - see item 13**
- Item 17*** **Heat reclaim mode solenoid valve status/test**
- Item 18** **Local interface test**
 This item is only used in test mode. It causes all the LEDs on the user interface to light up or flash, so as to check that they are working properly.

* See items 7 and 8
 ** See item 9

4.2.10 - Description of the CONFIGURATION menu

This menu can be used to display and modify user configurations.

A configuration can only be modified when the machine is fully stopped (LOFF). However, the password must have been entered in the Configuration menu in order to access this feature.



ITEM	FORMAT	DESCRIPTION
0	nn	Password
	«no»	Password invalid
	«Good»	Password valid
1*	b	Lead/lag select
2*	b	Loading sequence select
3	nn	Delay at start-up in minutes
4	b	Select ramp loading
5	b	Select reset type
6	b	Select demand limit type
7	nn.n	Software version
8	nnn	Network element address
9	nnn	Network bus number

Key:

* : This item is displayed in certain unit configurations only.
 b : 1=Yes; 0=No
 n : numerical display
 : characters

- Item 0** **Password**
 A password must be entered in order to access the test function or modify a user configuration. The password has a default value of 11. This value can be modified by Carrier Service with the aid of special tools. If the message “no” is displayed in block 2, it means that a password must be entered or was entered incorrectly. The message “Good” means that the password has been validly entered or that the password already entered is still valid. The controller automatically deactivates the password after 5 minutes without activity (i.e. no buttons pressed) or after powering up.

For example: “enter password”.

OPERATION	PRESS KEY	BLOCK 3 LED	BLOCK 1 DISPLAY	BLOCK 2 DISPLAY
Hold down the MENU button until the LED for Configuration lights. Block 2 displays “no”, showing that the password must be entered			0	No
Press the button to authorise modification of the value associated with item 0. The Configuration menu LED flashes to show that the value can be modified.			0	0
Press until the value 11 is displayed in block 2. The Configuration menu LED keeps flashing.			0	11
Press the button again to validate. The Configuration menu LED stops flashing. “Good” is displayed if the password is correct.			0	Good

- Item 1** **Select lead circuit**
 Default: 0
 Range: 0, 1 or 2
 Config.: 0 = automatic depending on the number start-ups of each circuit
 1 = Circuit A leader
 2 = Circuit B leader
- Item 2** **Circuit loading sequence**
 Default: 0
 Range: 0 or 1
 Config.: 0 = Equal circuit loading
 1 = Priority loading on one circuit

NOTE: This configuration is not available on single-circuit units.

- Item 3** **Delay at start-up delay**
 Default: 2 minutes
 Range: 2 to 15 minutes

NOTE: This value is reinitialised after power up or when both circuits are halted by a local, remote or CCN command.

No compressor will be started up until this pause has expired. However, the evaporator water pump command will be activated immediately. The safety lockout loop will not be checked until the pause has expired.

Item 4 Select ramp loading
 Default: 0
 Range: 0 or 1
 Config.: 0 = Ramp disabled
 1 = Ramp enabled

NOTE: This configuration enables the ramp to be activated for heating and cooling modes: the maximum rate (in °C/min) of temperature drop (in cooling mode) or temperature rise (in heating mode) for the water leaving the active heat exchanger. However, each mode has its own ramp setting which can be configured in the Configuration menu.

Item 5 Leaving water temperature reset select
 Default: 0
 Range: 0, 1 or 2
 Config.: 0 = Reset not selected
 1 = Reset based on returning water temperature
 2 = Reset based on an external 0-10 V d.c. signal

NOTE: Reset based on a 0-10 V d.c. signal has precedence over 0-10 V d.c. demand limit: if 0-10 V d.c. reset has already been selected, then the selection of limitation by a 0-10 V d.c. signal will be automatically disabled.

Item 6 Select demand limit type
 Default: 0
 Range: 0, 1 or 2
 Config.: 0 = Limitation not selected
 1 = Limitation based on an external contact
 2 = Limitation based on an external 0-10 V d.c. signal

NOTE: Limitation based on an external 0-10 V d.c. signal. With this configuration, a value of 0 volt will enable the unit to operate at full capacity (100%), and a value of 10 volts will limit demand completely (0%). Between these two values, limitation shall exhibit a linear slope. However, these reference voltage values (0 and 10 volts) are configurable (by Carrier Service only), so that their upper and lower values or the direction of the limitation slope can be modified.

CAUTION: Reset based on a 0-10 V d.c. signal has precedence over 0-10 V d.c. demand limit: if 0-10 V d.c. reset has already been selected, then the selection of limitation by a 0-10 V d.c. signal will be automatically disabled.

Item 7 Software version number

NOTE: This item shows the number of the software version used by this controller. Access is read-only.

Item 8 CCN element address
 Default: 1
 Range: 1 to 239

NOTE: No two network elements can have the same element number and bus number at the same time.

Item 9 CCN bus number
 Default: 0
 Range: 0 to 239

NOTE: No two network elements can have the same element number and bus number at the same time.

4.2.11 - Description of the ALARMS menu

This menu can be used to display and reset up to 5 active alarms.



ITEM	FORMAT	DESCRIPTION
0	n «AL»	n alarms active/alarm resets
1*	nnn	Active alarm code 1
2*	nnn	Active alarm code 2
3*	nnn	Active alarm code 3
4*	nnn	Active alarm code 4
5*	nnn	Active alarm code 5

Key:

n : numerical display







* : This item is displayed if the alarm is active

Item 0 Number of alarms active/Reset all alarms

This item displays the number of alarms active (e.g. “3 AL” means that 3 alarms are active) and also allows them to be reset even if the unit is operating. If there are no alarms active, “0 AL” is displayed in block 2.

To reset active alarms, press the  button twice in succession when this item is displayed.

For example: Reset active alarms

OPERATION	PRESS KEY	BLOCK 3 LED	BLOCK 1 DISPLAY	BLOCK 2 DISPLAY
Hold down the MENU button until the LED for Alarms lights. Block 2 displays the number of alarms active (2 alarms in this example).	 ⋮ 		0	0
Press the A button to authorise the alarms to be reset. The Alarm menu LED flashes and 0 is displayed in block 2.			0	0
Press the A button again to validate the reset. The Alarm menu LED stops flashing. “Good” is displayed for two seconds, then ‘2AL’ and finally ‘0 AL’.			0	Good then 2 AL then 0 AL

Items 1 to 5 Active alarm code number

See section 6.4 for a list and complete description of the alarm codes.

4.2.12 - Description of the ALARMS HISTORY menu

This menu lets you display the last 10 alarms to have been reset.



ITEM	FORMAT	DESCRIPTION
0*	nnn	Alarms history 1
1*	nnn	Alarms history 2
2*	nnn	Alarms history 3
3*	nnn	Alarms history 4
4*	nnn	Alarms history 5
5*	nnn	Alarms history 6
6*	nnn	Alarms history 7
7*	nnn	Alarms history 8
8*	nnn	Alarms history 9
9*	nnn	Alarms history 10

Key:

n : Numerical display

* : This item is displayed if the alarm exists

4.2.13 - Description of the OPERATING LOG menu

This menu lets you display the operating times and number of start-ups for the machine, circuits and compressors. The values displayed are divided by 10 (except for the last two items), so that numbers of hours or start-ups of less than 10 are displayed as 0.



ITEM	FORMAT	DESCRIPTION
0	nnnn	Number of unit operating hours/10
1	nnnn	Number of operating hours circuit A/10
2	nnnn	Number of operating hours compressor A1/10
3*	nnnn	Number of operating hours compressor A2/10
4	nnnn	Number of operating hours circuit B/10
5*	nnnn	Number of operating hours compressor B1/10
6*	nnnn	Number of operating hours compressor B2/10
7	nnnn	Number of unit start-ups/10
8	nnnn	Number of start-ups compressor A1/10
9*	nnnn	Number of start-ups compressor A2/10
10	nnnn	Number of start-ups compressor B1/10
11*	nnnn	Number of start-ups compressor B2/10
12	nn	Maximum number of start-ups during the last hour
13	nn	Average maximum number of start-ups during the last 24 hours

Key:

n : Numerical display

* : This item is displayed in certain unit configurations only.

4.2.14 - Default user interface display

The default display is activated when the keypad has remained inactive for 5 minutes.

The user interface displays in turn:

- The heat exchanger leaving water temperature (evaporator in cooling mode and condenser in heating mode).

In addition:

- Active operating type: "LOFF", "L-C1", "L-C2", "L-H", "LC1r", "LC2r", "CCn", "rEM".
- "SM" of the unit is under the control of a System Manager (FSM or CSM III).
- "MASt" if the Master/Slave function has been activated and the unit is the master.
- "SLA" if the Master/Slave function has been activated and the unit is a slave.

4.3 - Summary interface

4.3.1 - General

The summary interface includes a mimic diagram of the unit, together with pushbuttons and LEDs. It gives quick access to the main operating parameters of the unit. The summary interface shown below is for a dual-circuit water-cooled unit.

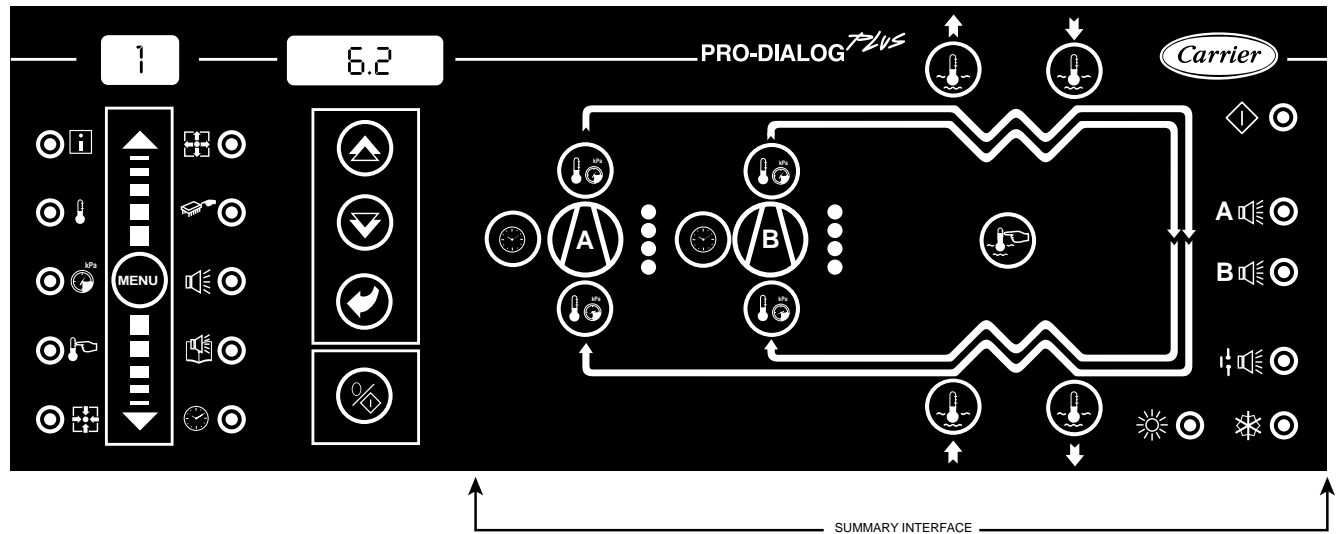

4.3.2 - Description of the LEDs

LED	INDICATION WHEN LIT
	Green LED: the unit is authorised to start or is already running
A	Red LED: <ul style="list-style-type: none"> Lit = circuit A or unit shut down by alarm Flashing = circuit A or unit running with alarm present
B	Red LED: <ul style="list-style-type: none"> Lit = circuit B or unit shut down by alarm Flashing = circuit B or unit running with alarm present
	Red LED: Lock contact open
	Green LED: the unit is in cooling mode
	Green LED: the unit is in heating mode
	Yellow LEDs: from top to bottom - start/stop status of compressors A1 and A2. A flashing LED indicates that the HP load shedding option is active on circuit A.
	Yellow LEDs: from top to bottom - start/stop status of compressors B1 and B2. A flashing LED indicates that the HP load shedding option is active on circuit B.

Key:

* : LED available depending on unit configuration.

4.3.3 - The push buttons

The buttons allow immediate access to certain information (items) supplied by the main interface. Pressing one of these buttons causes the value of the item to be displayed immediately in block 2 and the number of the corresponding item to be displayed in block 1. It also lights the LED for the menu containing this information. Pressing the same button several times displays several pieces of information in succession.

LED	DISPLAY
	Evaporator/condenser leaving water temperature in °C
	Evaporator/condenser entering water temperature in °C
	Control point (setpoint + reset) in °C
	Press 1: Circuit A discharge pressure in kPa Press 2: Circuit A saturated condensing temperature in °C
	Press 1: Circuit A suction pressure in kPa* Press 2: Circuit A saturated suction temperature in °C*
	Press 1: Compressor A1/B1 operating hours in h/10* Press 2: Compressor A2/B2 operating hours in h/10*

Key:

* : Button available depending on unit configuration.

h : Hours

5 - PRO-DIALOG PLUS CONTROL OPERATION

5.1 - Start/stop control

The unit is in stop mode and is not authorised to start up if at least one of the following conditions is met:

- The unit is in Local Off operating type (LOFF): mode 1 is active.
- The unit is in operating type Remote (rEM) and the controller has received a stop command over a volt-free contact connected to the customer terminal block: mode 3 is active.
- The unit is in operating type CCN (CCn) and either:
 - the controller has received a stop command over the network: mode 2 is active; or
 - the controller has received a start command over the network but start/stop control by volt-free contact is authorised in CCN mode and the controller has received a stop command over a volt-free contact connected to the customer terminal block: mode 2 is active.
- The delay at start-up has not expired: mode 7 is active.
- The unit is in the process of switching from heating to cooling mode: it has completely stopped before restarting.
- CCN has commanded an emergency shutdown (EMSTOP activated).
- The unit is totally shut down due to an alarm.

The unit is authorised to start if it is not in stop mode (see above) and if one of the following conditions is met:

- The unit is in Local operating type (L-C1, L-C2, L-H, LC1r, LC2r): mode 4 is active.
- The unit is in Remote operating type (rEM) and the controller has received a start command over a volt-free contact connected to the customer terminal block: mode 6 is active.
- The unit is in CCN operating type (CCn) and the controller has received a start command over the network, and either:
 - start/stop control by volt-free contact is not authorised in mode CCN: mode 5 is active; or
 - start/stop control by volt-free contact is authorised in mode CCN and the controller has received a start command over a volt-free contact connected to the customer terminal block: mode 5 is active.

NOTE: In CCN operating mode, it is possible to authorise unit start/stop over a volt-free contact connected to the customer's terminal block. This configuration (which must be carried out by Carrier Service) is exceptional and generally only used for controlling a master unit in a master/slave grouping (see section 5.18).

5.2 - Heating/cooling selection

On heat pumps, heating/cooling selection can be controlled differently depending on the active operating type:

- Locally on the unit, using operating types L-C1, L-C2, LC1r and LC2r (for cooling) and L-H (for heating).
- Remotely using the heat/cool selection volt-free contact when the unit is in Remote operating type (rEM).
- Via a CCN command when the unit is in CCN operating type (CCn).

The current heat/cool operating mode on the unit is indicated by item 4 in the Information menu and by the heat/cool LEDs on the summary interface.

5.3 - Evaporator water pump control

The evaporator water pump is started when the unit is in the running mode described above or in delay at start-up mode (i.e. mode 7). Since the minimum value for the delay at start-up is 2 minutes (configurable between 2 and 15 minutes), the pump will run for at least two minutes before the first compressor starts. The pump is kept running for one minute after the unit goes to stop mode. The pump keeps working when the unit is switching from heating to cooling mode or vice-versa. It is turned off if the unit is shut down due to an alarm unless the fault is a frost protection error or risk of freezing.

5.4 - Condenser water pump control

Only available on water-cooled units.

The condenser pump can be controlled by two modes, depending on the configuration (only accessible by Carrier Service).

- 1 - Control based on unit start/stop control. In this case it is controlled in the same way as the evaporator pump.
- 2 - Control based on compressor status. In this case the pump is activated at the same time as the first compressor. It only switches off when no compressor is activated.

5.5 - Control point

Control point represents the leaving water temperature that the unit must produce.

- In cooling mode: control point = active setpoint + reset
- In heating mode: control point = active setpoint - reset

5.5.1 - Active setpoint

Two setpoints can be selected as active in cooling mode. Usually, the second setpoint is used for unoccupied periods or for ice storage (medium or low brine unit). A single setpoint is available in heating mode.

Depending on the current operating mode, the active setpoint can be selected with the operating type selector button, or with the user's volt-free contacts, or with network commands (see section 4.2.7).

5.5.2 - Reset

Reset means that the active setpoint is modified in such a way that the capacity required by the unit is less (in cooling, the setpoint is increased, and in heating it is lowered). This modification is in general a reaction to a drop in the load. For the PRO-DIALOG control system, the source of the reset can be configured: it can be delivered either by an external 0-10 V d.c. signal (e.g. outside temperature probe) or by the return water temperature. In both cases the reset parameters, i.e. slope, source and maximum value, are configurable in the Setpoints menu (see section 4.2.7) and are also independent for the heating and cooling modes.

5.6 - Demand limit

Generally, demand limit is used by an energy management system in order to restrict the unit electricity consumption.

The PRO-DIALOG control system for 30GX & 30HX provides two methods of demand limit:

- By reference to a limiting signal from a user-controlled volt-free contact: the capacity of the unit cannot exceed the demand limit setpoint (which can be modified in the Setpoints menu) when the limit contact is closed.
- By reference to an external 0-10 V d.c. signal: the capacity of the unit cannot exceed the demand limit imposed by this external signal. It is a linear function and its parameters are configurable by Carrier Service (voltages at 0% limitation and 100% of limitation). This function is not available if Reset by reference to an external 0-10 V d.c. signal has already been selected.

Whatever the method used, demand limit is active in all operating types: Local, Remote or CCN. However, in Local operating type, demand limit can be disabled with keypad commands (see section 4.2.4) and in CCN operating type, demand limit can be controlled directly with the aid of CCN commands.

Note: A limitation value of 100% means that the unit may call upon the full array of its capacity stages.

Here is an example of demand limit by an external 0-10 V d.c. signal. This example assumes that the limitation parameters are such that at 0 volt the authorised capacity shall be maximum capacity, and at 10 volts the authorised capacity shall be zero (this is the default configuration).

Demand limit by 0-10 V d.c. signal

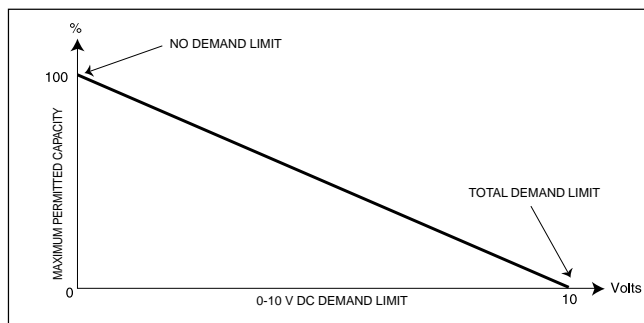

5.7 - Capacity control

This function adjusts the number of active compressors and loaders to keep the leaving water temperature at its setpoint. The **precision** with which this is achieved depends on **the capacity of the water loop, the flow rate, the load, and the number of stages available on the unit.**

The control system continuously takes account of the temperature error with respect to the setpoint, as well as the rate of change in this error and the difference between entering and leaving water temperatures, in order to determine the optimum moment at which to add or withdraw a capacity stage.

NOTE: If the same compressor undergoes too many starts (per hour) this automatically brings about reduction of compressor starts, which makes leaving water temperature control less precise.

5.8 - Determining the lead circuit

This function commands the start/stop sequence of the two refrigerant circuits called A and B. The circuit authorised to start first is the lead circuit. Three methods can be configured by the user in the Configuration menu:

- **Auto mode:** the control system determines the lead circuit so as to equalise the number of starts on each circuit (value weighted by the operating times of each circuit). Thus, the circuit with the least number of starts is always given precedence to start. The lead circuit is stopped last.
- **Circuit A as leader:** Circuit A is always the lead circuit. It is the first to start and the last to stop.
- **Circuit B as leader:** Circuit B is always the lead circuit. It is the first to start and the last to stop.

5.9 - Circuit loading sequence

Two circuit loading sequences are available. The choice of sequence can be configured by the user in the Configuration menu (see section 4.2.10).

- **Balanced circuit loading:** If this sequence is selected, the control system tries to keep the capacity of circuits A and B equal as the total load on the unit increases or decreases.
- **Loading with priority given to one circuit:** If this sequence is selected, the control system loads the lead circuit completely before the second circuit starts up. When there is a demand limit, the second circuit is unloaded first.

NOTE: 30HX and 30GX units use 06N twin screw compressors. The screw compressor efficiency is better at full load than at part load. By default the close control configuration (temperature precision has priority over compressor efficiency - this parameter is only accessible by Carrier Service) is not validated, and the control will always try to optimise unit efficiency.

5.10 - Compressor start-up sequence in one circuit

The first compressor to start is the one with the least number of start-ups and operating hours. If both compressors are operating and the load decreases, the compressor that started first shuts down. This avoids cycling of their same compressor.

5.11 - Controlling the EXV

EXVs control the refrigerant flow in the evaporator. Each circuit has a liquid level detector that is mounted vertically high in the evaporator shell. The level detector consists of a small electric resistance heater and of three thermistors wired in series and mounted at different levels inside the well body. The heater is used so that the thermistors reach approximately 93°C dry air. As the refrigerant level increases in the evaporator, the resistance of the nearest thermistor(s) changes considerably. This difference in resistance permits precise control of the specified level, modulating the EXVs.

5.12 - Motor cooling valve control

The temperature of the motor windings is controlled to a setpoint of 85°C. This is achieved by cycling of the motor cooling valves to allow the refrigerant to flow across the motor windings, if necessary. For units with economizer, instantaneous vapour leaves the high side of the economizer and continuously flows across the motor windings. All refrigerant used for motor cooling returns to the rotors through an orifice situated mid-way along the compression cycle and is compressed to the discharge pressure.

5.13 - Head pressure control on air-cooled units

- The saturated condensing temperature is controlled by reference to a fixed setpoint (user-definable in the Setpoints menu). This temperature is maintained by cycling fans on and off, as well as by varying the speed of a fan.

NOTE: Certain units can have up to 4 fan stages and a variable speed fan per circuit, depending on their configuration and wiring.

5.14 - Head pressure control on water-cooled units

- The saturated condensing temperature is controlled by reference to a user-definable fixed setpoint. This temperature is maintained by using the valve to control the flow of water in each condenser circuit.

5.15 - Head pressure setpoint selection

There are two head pressure setpoints available: the first is called “head pressure setpoint” and the second “reclaim setpoint”. These setpoints only have an effect when the control system is controlling head pressure: air or water-cooled units operating in cooling mode (only when they are fitted with condenser water valves).

The active setpoint can be selected in one of the following ways:

- With the operating type selector button: selections L-C1 and L-C2 activate the head pressure setpoint. Selections LC1r and LC2r activate the reclaim setpoint (see section 4.2.2, description of the operating modes).
- With a volt-free selection contact connected to the customer terminal block when the unit is in Remote operating type (rEM). See section 3.4.4, description of the control contacts.
- With a network command when the unit is in CCN operating type (CCn).

5.16 - High pressure load shedding function

This function does not require an additional board. It prevents high pressure breaks on a circuit by the following means:

- Preventing any capacity increase on the circuit once the high pressure value has reached an initial threshold.
- Shedding one or more capacity stages once a second protection threshold has been reached.

In the event of capacity stages being shed, no capacity increase will be authorised on the circuit concerned for a period of 5 minutes.

NOTE: The last capacity stage cannot be shed by this protection function. An alarm is activated, if the high pressure is still too high.

5.17 - Start-up procedure - prelubrication

This procedure describes the necessary procedures to ensure the lubrication of the compressor before start-up.

The control follows the sequence below:

For the lead compressor (the first compressor in the circuit to start):

1. Start the oil pump and measure the initial oil pressure.
2. Wait approximately 30 seconds.
3. Verify the oil solenoid valve tightness, i.e.: if oil pressure increases and the solenoid valve is not open, the oil solenoid valve failure alarm is activated and prelubrication is stopped. The procedure is aborted.
4. If not, the oil solenoid valve is activated.
5. Wait approximately 15 seconds.
6. If oil pressure increases, prelubrication is assured and the compressor can start.
7. If not, a further prelubrication cycle is started. Return to point 1.

NOTE: After three cycles, the low oil pressure alarm at pre start-up is activated, and prelubrication is also stopped.

For the lag compressor (one compressor in the circuit is already in operation).

1. Activate the oil solenoid valve.
2. Wait approximately 15 seconds.
3. If oil pressure increases, prelubrication is assured and the compressor can now start.
4. If not, the low oil pressure at start-up alarm is activated and the prelubrication is also stopped.

5.18 - Master/slave assembly

5.18.1 - General

Two PRO-DIALOG Plus units can be linked to produce a master/slave assembly. This feature is only authorised in cooling mode. The two machines are interconnected over the CCN bus. To operate as master/slave, both units must have their chilled water temperature probes located on the common evaporator entering and leaving line. In addition interlock control of the cooler water flow and a freeze protection switch is imperative on each unit.

The master/slave link only operates when both units are in CCN operating mode. The master/slave assembly will be inactive in the following cases:

- If either of the chillers is in Local or Remote mode, or in heating mode.
- A demand limit command is sent to the slave unit.
- One of the following CCN variables is forced on the slave unit: start unit, demand limit or control point.

All control commands to the master/slave assembly (start/stop, setpoint, load shedding, etc.) are handled by the unit which is configured as the master, and must therefore only be applied to the master unit. They will be transmitted automatically to the slave unit. Therefore to start up the assembly, simply validate operating mode CCN (i.e. CCn) on the master unit (with the CCN start/stop variable previously forced to Enable). The slave unit stays in CCN operating type continuously. To stop the master/slave assembly, select Local Off (LOFF) on the master unit. In some cases with a specific configuration, remote volt-free contacts can be used to control unit start/stop or to select setpoint 1 or 2, even though both units are still in CCN operating mode.

NOTE: All parameters required for the master/slave function must be configured by Carrier Service.

5.18.2 - Balancing running times between master and slave

The master unit (depending on its configuration) may have as part of its functions to designate whether the master or slave is to be the head machine or the follower. The roles of head machine and follower will be reversed when the difference in running hours between the two units exceeds a configurable value, ensuring that the running times of the two chillers are automatically equalised. The changeover between head machine and follower may take place when the assembly is started up, or even whilst running.

The running time balancing function is not active when:

- It has not been configured: in this case the head machine is always the master unit.
- A demand limit is applied to the master unit: in this case the head machine will always be the master unit until the demand limit is lifted.

5.18.3 - Starting the follower unit

The head machine will always be started first. When the head machine is at its full available capacity, the start-up delay (configurable) is initialised on the follower. When this delay has expired, and if the error on the control point is greater than 1.7°C, the follower unit is authorised to start and the pump is activated. The follower will automatically use the master unit's active setpoint. The head machine will be held at its full available capacity for so long as the active capacity on the follower is not zero. When the follower unit is commanded to stop, its cooler water pump is turned off with one minute delay.

5.18.4 - Abnormal operating conditions

In the event of a communication fault between the two units, each shall return to an autonomous operating mode until the fault is cleared. If the master unit is halted due to an alarm, the slave unit shall be authorised to start without prior conditions.

5.19 - Controlling a Pro-Dialog Plus unit with a System Manager

Up to 8 PRO-DIALOG Plus units (or System Manager compatibles) can be controlled by one control module of the FSM or CSM III type which can handle multi-tasking of control functions such as starting units in sequence.

5.20 - Optional heat reclaim module

This option only applies to air-cooled units, equipped with a water-cooled heat reclaim condenser. An additional 4 x DO board must be installed. This board permits control of:

- two solenoid shutoff valves for the heat reclaim coil, one per circuit.
- two drain solenoid valves, one per circuit. These permit draining the refrigerant from the inactive coil, when the unit changes over from the cooling mode to the heat reclaim mode.

Selecting the heat reclaim mode can be done with either the local interface or remotely with the (recl_sw) contact or by CCN.

The heat reclaim function is active when: the heat reclaim entering water temperature is lower than the heat reclaim setpoint, minus half of the heat reclaim dead band.

The heat reclaim function is not active when: the heat reclaim entering water temperature is higher than the heat reclaim setpoint, plus half of the heat reclaim dead band.

In the dead band the function remains in its active mode. The default value of the dead band is 4.4°C. This value can be modified by Carrier Service.

Change-over procedure from cooling mode to heat reclaim mode:

- Start-up of the condenser pump
- Verification of the condenser flow switch control contact. If this remains open after one minute of condenser pump operation, the circuit remains in cooling mode and alarm 83 for circuit A (alarm 84 for circuit B) will be activated.
- As soon as the saturated condensing temperature reaches 30°C and the superheat reaches 8.3 K, the pumpdown sequence is activated.
- Pumpdown: closing of the cooling mode coil shutoff valve. Opening of the drain valve, closing of the EXV valve.
- As soon as the drain pressostat contact (contact pd_a_sw for circuit A, item 10 of the INPUTS menu (contact pd_b_sw for circuit B, item 11 of the INPUTS menu) is open, the drain valve will close and the heat reclaim function is active.

Item 17, **hr_status**, of the INFORMATION menu permits consulting different heat reclaim function sequences:

hr_status with format n1n2 with:

- n1 = sequence of circuit A
- n2 = sequence of circuit B
- 0 = cooling mode
- 1 = heat reclaim mode selection
- 2 = pumpdown sequence
- 3 = effective heat reclaim mode
- 4 = pumpdown fault*
- 5 = water flow switch fault*

* Alarm 83 for circuit A or 84 for circuit B is activated. Consulting the item hr_status gives cause as (4) or (5). Resetting of the alarms re-initialises the information of hr_status.

6 - DIAGNOSTICS - TROUBLESHOOTING

6.1 - GENERAL

The PRO-DIALOG Plus control system has many fault tracing aid functions. The local interface and its various menus give access to all the units operating conditions. The test function makes it possible to run a quick test of all the devices on the unit.

If an operating fault is detected, an alarm is activated and an alarm code is stored in the Alarm menu.

6.2 - Displaying alarms

The alarm LEDs on the summary interface (see section 4.3.2) give a quick display of the status of each circuit and the unit as a whole.









- A flashing LED shows that the circuit is operating but there is an alarm.
- A steady LED shows that the circuit has been shut down due to a fault.

The Alarm menu on the main interface displays up to 5 fault codes that are active on the unit.

6.3 - Resetting alarms

When the cause of the alarm has been corrected the alarm can be reset, depending on the type, either automatically on return to normal, or manually when action has been taken on the unit.

A manual reset must be run from the main interface using the following procedure:

OPERATION	PRESS KEY	BLOCK 3 LED	BLOCK 1 DISPLAY	BLOCK 2 DISPLAY
Hold down the MENU button until the LED for Alarms lights. Block 2 displays the number of alarms active (2 alarms in this example).	 ⋮ 		0	
Press the  button to authorise the alarms to be reset. The Alarm menu LED flashes and 0 is displayed in block 2.			0	0
Press the  button again to validate the reset. The Alarm menu LED stops flashing. "Good" is displayed for two seconds, then '2AL' again, and finally '0 AL'.			0	Good then 2 AL then 0 AL

Alarms can be reset even if the unit is running. This means that an alarm can be reset without stopping the machine.

In the event of a power supply interrupt, the unit restarts automatically without the need for an external command. However, any faults active when the supply is interrupted are saved and may in certain cases prevent a circuit or unit from restarting.

6.4 - Alarm codes

The following list gives a complete description of each alarm code and its possible cause.

ALARM CODE DESCRIPTIONS

Alarm code	Description	Why was this alarm generated?	Action taken by the control	Reset type	Probable cause
1	Evaporator entering fluid thermistor failure	Thermistor outside range -40 to 118°C	Unit shut down	Automatic	Thermistor or wiring fault
2	Evaporator leaving fluid thermistor failure	Thermistor outside range -40 to 118°C	Unit shut down	Automatic	Ditto
3	Condenser entering fluid thermistor failure	Thermistor outside range -40 to 118°C	None, simple message	Automatic	Thermistor or wiring fault or cable/wire damaged
4	Condenser leaving fluid thermistor failure	Thermistor outside range -40 to 118°C	None in cooling mode Unit shut down in heating mode	Automatic	Ditto
5	Heat reclaim condenser entering fluid thermistor failure	Thermistor outside range -40 to 118°C	None, simple message	Automatic	Ditto
6	Heat reclaim condenser leaving fluid thermistor failure	Thermistor outside range -40 to 118°C	None, simple message	Automatic	Ditto
7	Discharge gas thermistor failure, circuit A	Thermistor outside range -40 to 118°C	Circuit A shut down	Automatic	Thermistor solenoid, motor cooling or wiring fault or high discharge temperature
8	Discharge gas thermistor failure, circuit B	Thermistor outside range -40 to 118°C	Circuit B shut down	Automatic	Ditto
9	Motor sensor compressor A1	Thermistor outside range -40 to 118°C	Compressor A1 shut down	Automatic	Thermistor, solenoid, motor cooling or wiring fault
10	Motor sensor compressor A2	Thermistor outside range -40 to 118°C	Compressor A2 shut down	Automatic	Ditto
11	Motor sensor compressor B1	Thermistor outside range -40 to 118°C	Compressor B1 shut down	Automatic	Ditto
12	Motor sensor compressor B2	Thermistor outside range -40 to 118°C	Compressor B2 shut down	Automatic	Ditto
13	External 0-10 V dc signal fault	Signal outside range	1- Loadshed: not used 2- Demand limit: deactivated	Automatic	Defective input or wiring fault
14	Discharge pressure transducer failure, circuit A	Measured signal = 0V dc	Circuit A shut down	Automatic	Defective transducer, wiring fault
15	Discharge pressure transducer failure, circuit B	Measured signal = 0V dc	Circuit B shut down	Automatic	Ditto
16	Suction pressure transducer failure, circuit A	Measured signal = 0V dc	Circuit A shut down	Automatic	Ditto
17	Suction pressure transducer failure, circuit B	Measured signal = 0V dc	Circuit B shut down	Automatic	Ditto
18	Oil pressure transducer failure, compressor A1	Measured signal = 0V dc	Compressor A1 shut down	Automatic	Ditto
19	Oil pressure transducer failure, compressor A2	Measured signal = 0V dc	Compressor A2 shut down	Automatic	Ditto
20	Oil pressure transducer failure, compressor B1	Measured signal = 0V dc	Compressor B1 shut down	Automatic	Ditto
21	Oil pressure transducer failure, compressor B2	Measured signal = 0V dc	Compressor B2 shut down	Automatic	Ditto
22	Economizer A1 transducer failure	Measured signal = 0V dc	Circuit A shut down for unit with economizer. Otherwise compressor A1 shut down.	Automatic	Ditto
23	Economizer A2 transducer failure	Measured signal = 0V dc	Compressor A2 shut down	Automatic	Ditto
24	Economizer B1 transducer failure	Measured signal = 0V dc	Circuit B shut down for unit with economizer. Otherwise compressor B1 shut down.	Automatic	Ditto
25	Economizer B2 transducer failure	Measured signal = 0V dc	Compressor B2 shut down	Automatic	Ditto
26	Transducer supply defective	Ref. voltage supplied by main board outside range 4.4 V-5.5 V	Unit shut down	Automatic	Basic board failure or wiring fault
27	Evaporator liquid level sensor failure, circuit A	Sensor reading outside range -40 to 118°C	Circuit operates, but EXV control based on discharge superheat	Automatic	Open thermistor, liquid level sensor defective, wiring fault
28	Evaporator liquid level sensor failure, circuit B	Sensor reading outside range -40 to 118°C	Ditto	Automatic	Ditto
29	Loss of communication with CPM A1 board	CPM A1 board does not respond	Compressor A1 shut down	Automatic	Bus wiring fault, incorrect address or defective board
30	Loss of communication with CPM A2 board	CPM A2 board does not respond	Compressor A2 shut down	Automatic	Ditto
31	Loss of communication with CPM B1 board	CPM B1 board does not respond	Compressor B1 shut down	Automatic	Ditto
32	Loss of communication with CPM B2 board	CPM B2 board does not respond	Compressor B2 shut down	Automatic	Ditto
33	Loss of communication with 4xDO #1 board	4xDO board associated with CPM A1 does not respond	Circuit A shut down	Automatic	Ditto
34	Loss of communication with 4xDO #2 board	4xDO board associated with CPM A2 does not respond	Compressor A2 shut down	Automatic	Ditto
35	Loss of communication with 4xDO #3 board	4xDO board associated with CPM B1 does not respond	Circuit B shut down	Automatic	Ditto
36	Loss of communication with 4xDO #4 board	4xDO board associated with CPM B2 does not respond	Compressor B2 shut down	Automatic	Ditto
37	Loss of communication with EXV board, circuit A	4xDO board controlling EXV circuit A does not respond	Circuit A shut down	Automatic	Ditto
38	Loss of communication with EXV board, circuit B	4xDO board controlling EXV circuit B does not respond	Circuit B shut down	Automatic	Ditto
39	Loss of communication with fan board #1	4xDO board controlling the first four fan stages does not respond	Unit shut down if number of fan stages by circuit is lower than three. Otherwise circuit A shut down.	Automatic	Ditto
40	Loss of communication with fan board #2	4xDO board controlling the fan stages of circuit B does not respond	Circuit B shut down	Automatic	Ditto
41	Loss of communication with 4xAI - 2xAO #1 board	Analogue card does not respond	Unit shut down if operating in heating mode or using the speed controller or water valve. Otherwise simple message. EXV controls superheat, and no longer controls based on level indicator	Automatic	Ditto
42	Loss of communication with 4xAI - 2xAO #2 board	Analogue card does not respond	Unit shut down if economizer is used. Otherwise only compressors A1 + B1 are shut down.	Automatic	Ditto
43	Loss of communication with 4xAI - 2xAO #3 board	Analogue board does not respond	Shut down compressor A2 & B2	Automatic	Ditto
44	Discharge pressure circuit A too high	SCT>loadshed threshold. Max. satur. condensing pressure (mct_sp) if only one capacity stage remains in operation.	Circuit A shut down	Automatic in the 10 minutes that follow	Transducer/high pressure stat or fan circuit defective, condenser water flow restricted. condenser entering water or air temperature too high
45	Discharge pressure circuit B too high	SCT>loadshed threshold. Max. satur. condensing pressure (mct_sp) if only one capacity stage remains in operation.	Circuit B shut down	Automatic in the 10 minutes that follow	Ditto

Alarm code	Description	Why was this alarm generated?	Action taken by the control	Reset type	Probable cause
46	Oil solenoid failure, compressor A1	Oil pressure differential >17kPa during the period following pump start-up and before opening of the oil solenoid (see prelubrication)	Compressor A1 not authorised to start	Manual	Oil valve defective
47	Oil solenoid failure, compressor A2	Ditto	Compressor A2 not authorised to start	Manual	Ditto
48	Oil solenoid failure, compressor B1	Ditto	Compressor B1 not authorised to start	Manual	Ditto
49	Oil solenoid failure, compressor B2	Ditto	Compressor B2 not authorised to start	Manual	Ditto
50	Pre-start oil pressure, compressor A1	Oil pump does not sufficiently increase the pressure during several prelubrication cycles	Compressor A1 cannot start	Manual	Low oil level, oil pump, oil solenoid or oil transducer failure
51	Pre-start oil pressure, compressor A2	Oil pump does not sufficiently increase the pressure during several prelubrication cycles	Compressor A2 cannot start	Manual	Ditto
52	Pre-start oil pressure, compressor B1	Oil pump does not sufficiently increase the pressure during several prelubrication cycles	Compressor B1 cannot start	Manual	Ditto
53	Pre-start oil pressure, compressor B2	Oil pump does not sufficiently increase the pressure during several prelubrication cycles	Compressor B2 cannot start	Manual	Ditto
54	Oil level circuit A low	Oil level control contact open during operation	Circuit A shut down	Manual	Oil level detector defective, oil quantity insufficient
55	Oil level circuit B low	Oil level control contact open during operation	Circuit B shut down	Manual	Ditto
56	Low saturated suction temperature, circuit A	SST under defrost threshold* for 3 minutes	Circuit A shut down	Manual	Low refrigerant charge, filter drier obstructed, expansion valve and transducer defective, low water flow, low evaporator water temperature
57	Low saturated suction temperature, circuit B	SST under defrost threshold* for 3 minutes	Circuit B shut down	Manual	Ditto
58	High saturated suction temperature, circuit A	After 90 seconds of operation if SST > 12,8°C & EXV < 1%	Circuit A shut down	Manual	Expansion valve, liquid level sensor or transducer defective, high evaporator temp.
59	High saturated suction temperature, circuit B	After 90 seconds of operation if SST > 12,8°C & EXV < 1%	Circuit B shut down	Manual	Ditto
60	Low discharge superheat, circuit A	Superheat <2,8 K for 10 minutes	Circuit A shut down	Manual	Thermistor, transducer, EXV or economizer defective
61	Low discharge superheat, circuit B	Superheat <2,8 K for 10 minutes	Circuit B shut down	Manual	Ditto
62	Max. oil pressure difference, compressor A1	(Discharge pressure - oil pressure) >340 kPa for more than 6 seconds	Compressor A1 shut down	Manual	Obstructed oil filter, oil solenoid or shut-off valve blocked, or manual oil valve closed
63	Max. oil pressure difference, compressor A2	(Discharge pressure - oil pressure) >340 kPa for more than 6 seconds	Compressor A2 shut down	Manual	Ditto
64	Max. oil pressure difference, compressor B1	(Discharge pressure - oil pressure) >340 kPa for more than 6 seconds	Compressor B1 shut down	Manual	Ditto
65	Max. oil pressure difference, compressor B2	(Discharge pressure - oil pressure) >340 kPa for more than 6 seconds	Compressor B2 shut down	Manual	Ditto
66	Loss of communication with System Manager	The unit is controlled by a System Manager (Flotronic or Chiller) and communication with this module is lost for more than two minutes	Unit returns to autonomous operating mode	Automatic	Defective CCN BUS CCN wiring or system module failure
67	Loss of communication with master or slave unit	The master/slave link is broken due to a loss of communication between the two units for more than 2 minutes	Unit returns to autonomous operating mode	Automatic	Defective CCN BUS CCN wiring or loss of supply
68	Low oil pressure compressor A1	Oil pressure differential below the setpoint (dynamically calculated) for 15 seconds	Compressor A1 shut down	Manual	Low condenser air or water temperature, oil filters obstructed, oil valve blocked, oil solenoid and oil pressure transducer defective
69	Low oil pressure compressor A2	Oil pressure differential below the setpoint (dynamically calculated) for 15 seconds	Compressor A2 shut down	Manual	Ditto
70	Low oil pressure compressor B1	Oil pressure differential below oil setpoints 1 or 2 (see alert criteria for low oil pressure and setpoint)	Compressor B1 shut down	Manual	Ditto
71	Low oil pressure compressor B2	Oil pressure differential below the setpoint (dynamically calculated) for 15 seconds	Compressor B2 shut down	Manual	Ditto
72	Evaporator frost protection	Evaporator EWT or LWT below defrost setpoint	Unit shut down. Evaporator pump and if applicable heater start-up, if unit has shut down air-cooled units)	Automatic if the same alarm has not tripped the same day	Defective thermistor, low water flow
73	Condenser frost protection, circuit A	For water-cooled units and fluid type = water, if SCT<1,1°C	Unit shut down. Condenser pump start-up, if unit has shut down	Automatic	Discharge pressure transducer defective, refrigerant leak or low condenser water temperature
74	Condenser frost protection, circuit B	For water-cooled units and fluid type = water, if SCT<1,1°C	Unit shut down. Condenser pump start-up, if unit has shut down	Automatic	Ditto
75	Evaporator water flow control failure	1 - Control not closed, before end of the start-up delay or open during operation 2 - If shut-down control is active (accessible by Carrier Service) and control is closed, when pump is deactivated	Unit shut down. Pump shut down.	Manual	Evaporator pump control or water flow switch failure
76	Condenser water flow loss/thermostat box	Water flow switch (water-cooled units) not closed during the minute after start-up or open thermostat box, due to high temperature (air-cooled units)	Unit shut down	Manual	Condenser pump, low water flow, water flow switch, high thermostat box temperature or thermostat fault on air-cooled units
77	Unit emergency stop	CCN command received to shut down the unit	Unit shut down	CCN/Automatic	Network command

ALARM CODE DESCRIPTIONS (cont.)

Alarm code	Description	Why was this alarm generated?	Action taken by the control	Reset type	Probable cause
82	Communication loss with the 4 x DO heat reclaim board	4 x DO board does not respond	Unit shut down	Automatic	Defective bus wiring, incorrect address or defective board
83	Heat reclaim mode fault, circuit A	1. Interlock not closed 1 minute after condenser pump start-up or open during heat reclaim operation 2. More than two consecutive pumpdown sequences not successful.	Circuit A remains in cooling mode	Manual	1. Water flow switch defective. 2. Leak or heat reclaim shutoff or drain solenoid valve open.
84	Heat reclaim mode fault, circuit B	Ditto	Circuit B remains in cooling mode	Manual	Ditto
Alarm code					
1xx	Defect compressor A1	See CPM subcodes below	See CPM subcodes below	Manual	
2xx	Defect compressor A2	See CPM subcodes below	See CPM subcodes below	Manual	
3xx	Defect compressor B1	See CPM subcodes below	See CPM subcodes below	Manual	
4xx	Defect compressor B2	See CPM subcodes below	See CPM subcodes below	Manual	
CPM subcodes (XX)					
01	High pressurestat tripped	HPS port to CPM module open	Compressor shut down	Manual	Lack of condenser water flow. Condenser valve blocked, fan circuit fault, high condenser entering air or water temperature
02	No motor current	CPM module shows less than 10% of the MTA for more than 3 seconds	Compressor shut down	Manual	Power supply interrupted, fuse(s) blown, wiring fault, core defective
03	Current imbalance >10%	CPM shows the voltage imbalance between phases as more than 10% for 25 minutes	Compressor shut down, if threshold alarm is validated. Otherwise simple message.	Manual, if threshold alarm is validated. Otherwise automatic reset.	Loss of power supply, wiring fault, loose terminal, core defective
04	Current imbalance >18%	CPM shows the voltage imbalance between phases as more than 18% for 25 minutes	Compressor shut down, if threshold alarm is validated. Otherwise simple message.	Manual, if threshold alarm is validated. Otherwise automatic reset.	Poor power supply, loose terminal, core defective
05	Current drop in one phase	CPM shows the current imbalance between phases as more than 30% for 1.8 seconds	Compressor shut down	Manual	Motor fault, wiring fault
06	High motor current	CPM detects high current, based on MTA rating	Compressor shut down	Manual	Operation outside the compressor capacity. Configuration block badly perforated, motor fault
07	Ground current fault	CPM detects ground current (2.5 +/- 0 amps)	Compressor shut down	Manual	Ground current fault on motor winding, wiring fault
08	Voltage imbalance >3%	CPM shows the voltage imbalance between phases as more than 3% for 25 minutes	Compressor shut down, if threshold alarm is validated. Otherwise simple message.	Manual, if threshold alarm is validated. Otherwise automatic reset.	Compressor fault, power supply imbalance, wiring fault, loose terminal
09	Voltage imbalance >7%	CPM shows the voltage imbalance between phases as more than 3% for 25 minutes	Compressor shut down, if threshold alarm is validated. Otherwise simple message.	Manual, if threshold alarm is validated. Otherwise automatic reset.	Ditto
11	Voltage phase reversal	CPM detects phase reversal in the incoming power supply	The compressor does not start	Manual	Supply phases or cables reversed, reference voltages reversed on the CPM board, after replacement
12	Contactors failure	CPM detects 10% of the MTA for 10 seconds after shutdown of the compressor contactor. Oil solenoid still has supply.	Unit shut down	Manual	Defective/blocked contactor
13	Current phase reversal	CPM detects a current phase reversal via the core	Compressor shut down	Manual	Supply phases or cables reversed, core wiring reversed after replacement
14	High motor temperature	CPM detects high motor temperature, if temperature is higher than 110°C for 10 seconds	Compressor shut down	Manual	Solenoid, cooling motor defect, low refrigerant charge. Wiring, motor temperature sensor or CPM board fault
15	Motor thermistor open	CPM detects an open circuit at the motor temperature thermistor	Compressor shut down	Manual	Wiring fault, thermistor or board defective
16	Configuration block fault	CPM detects a reading fault at the block	Compressor shut down	Manual	Configuration block on CPM board badly perforated or badly placed. Defective board.
17	Thermistor short-circuited	CPM detects a short circuit at the motor temperature thermistor	Compressor shut down	Manual	Wiring fault, thermistor or board defective

Legend:

* Defrost threshold = 1.1°C for water or for the lowest cooling setpoint less 4.4°C for brine or low brine.

CPM: Compressor protection module

FSM: Flotronic System Manager™

CSM: Chiller System Manager

MTA: Compressor Must Trip Amperes



Order No. 13056-76, 03 1999. Supersedes order No.: 13056-76, April 1998
Manufacturer reserves the right to change any product specifications without notice.



Environmental Management System Approval

Manufactured by: Carrier S.A., Montluel, France.
Printed in the Netherlands on totally chlorine-free paper.