



TRANE®

Installation Operation Maintenance

RTAA-IOM-3

Library	Service Literature
Product Section	Refrigeration
Product	Rotary liquid Chillers – Air-Cooled
Model	RTAA
Literature Type	Installation, Operation, Maintenance
Sequence	3
Date	December 1991
File No.	SV-RF-RLC-RTAA-IOM-3-1291
Supersedes	

Air-Cooled Series R® Rotary Liquid Chillers

“CO” and Later Design Sequence

Packaged Air-Cooled Chiller,
RTAA 130-400

Remote Evaporator Air-Cooled Chiller,
RTAA 130-200

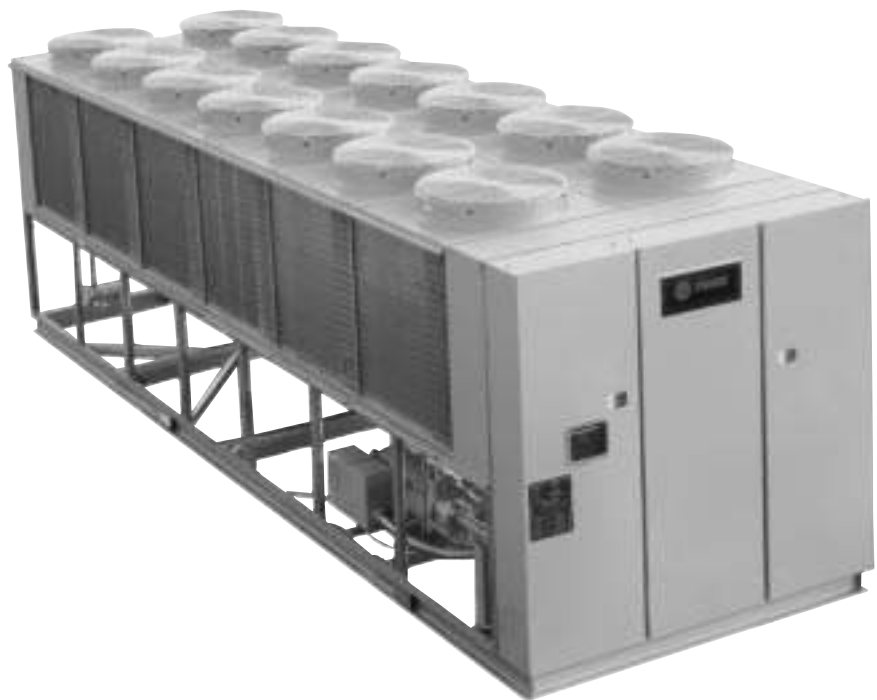

Models

RTAA-130
RTAA-140
RTAA-155

RTAA-170
RTAA-185
RTAA-200

RTAA-240
RTAA-270
RTAA-300

RTAA-340
RTAA-370
RTAA-400

Part No. X39560468-01

Since The Trane Company has a policy of continuous product improvement, it reserves the right to change specifications and design without notice. The installation and servicing of the equipment referred in this booklet should be done by qualified, experienced technicians.

Table of Contents

World environmental scientists have concluded, based on the best currently available evidence, that ozone in our upper atmosphere is being reduced due to release of CFC fully halogenated compounds.

Prior to installation, operation, service or maintenance on this equipment, refer to "Refrigerant Emission Control" in the Periodic Maintenance Section.

9	General Information	47	Installation - Mechanical, Remote Evaporator Interconnecting Refrigerant Piping
9	Literature Change History	47	General
9	Unit Identification	51	Line Sizing
9	Unit Inspection	51	— Equivalent Line Length
9	Inspection Checklist	51	— Liquid Line Sizing
9	Loose Parts Inventory	53	— Suction Line Sizing
10	Unit Description	54	Piping Installation Procedures
10	Commonly Used Acronyms	54	Refrigerant Sensors
20	Warnings and Cautions	56	Leak Test and Evacuation
20	Installation Responsibilities	56	Refrigerant and Additional Oil Charge
21	Nameplates	56	— Refrigerant Charge Determination
21	— Outdoor Unit Nameplate	56	— Oil Charge Determination
21	— Compressor Nameplate	57	Installation - Electrical
21	— Remote Evaporator Nameplate	57	General Recommendations
23	Storage	57	Installer-Supplied Components
25	Installation - Mechanical, Packaged Unit with Remote Evaporator	68	— Remote Evaporator Only
25	General	68	Power Supply Wiring
25	Pre-installation	68	— General
25	Location Requirements	68	— Control Power Supply
25	— Noise Considerations	68	— Heat Tape Power Supply (Packaged Units Only)
25	— Foundation	68	— Water Pump Power Supply
25	— Clearances	68	— Auxiliary Heat Tape Power Supply
31	— Additional Location Requirements for Remote Evaporator Only	69	Interconnecting Wiring
31	— Drainage	69	— Chilled Water Pump Interlock and External Auto/Stop
32	Rigging	69	— Chilled Water Pump Interlock
32	Lifting Procedures	69	— External Auto/Stop Wiring
36	Unit Isolation and Leveling	70	— Alarm/Running/Maximum Capacity Outputs
36	Evaporator Water Piping	71	— Alarm/Running/Maximum Capacity Indicator Wiring
41	— Evaporator Piping	71	Low Voltage Wiring
42	— Evaporator Piping Components	71	— Emergency Stop (Normal Trip)
42	— Entering Chilled Water Piping	71	— External Circuit Lockout - Circuit #1
42	— Leaving Chilled Water Piping	71	— External Circuit Lockout - Circuit #2
42	— Evaporator Drain	71	— Ice Making Option
42	— Evaporator Flow Switch	72	— External Chilled Water Setpoint (CWS) Remote Resistor/Potentiometer, Voltage Source 2-10 VDC or Current Source 4-20 mA
44	— Water Treatment	73	— External Current Limit Setpoint (CLS) Remote Resistor/Potentiometer, Voltage Source 2-10 VDC or Current Source 4-20 mA
44	— Water Pressure Gauges	74	— Optional Bidirectional Communication Link (BCL)
44	— Water Pressure Relief Valves	74	— General
44	— Freeze Protection	74	— Communication Link Connection Procedure
45	— Domestic Water Heater Piping	75	Installation Check List
45	— Domestic Water Heater Piping Components		
45	— Entering Water Piping		
45	— Leaving Water Piping		
45	— Water Pressure Relief Valves		
45	— Freeze Protection		

77 Operating Principles - Mechanical	121 Pre-Start Check-out
77 General	121 General
77 Refrigeration (Cooling) Cycle	122 Unit Voltage Power Supply
77 — Cycle Description	122 Unit Voltage Imbalance
77 — Compressor Description	123 Unit Voltage Phasing
77 — Compressor Motor	124 Water System Flow Rates
77 — Compressor Rotors	124 Water System Pressure Drop
77 — Compressor Loading Sequence	124 UCM Set-up
82 Oil System Operation	125 Start-up Procedures
82 — Overview	125 General
82 — Domestic Water Heater	125 System Superheat
83 — Oil Separator	125 System Subcooling
83 — Compressor Bearing Oil Supply	129 Unit Shutdown Procedures
83 — Compressor Rotor Oil Supply	129 Temporary Shutdown and Restart
84 — Slide Valve Movement	129 Extended Shutdown Procedure
84 — Oil Filter	130 System Restart After Extended Shutdown
84 — Condenser Fans	
87 Operating Principles -Adaptive Control™ Microprocessor Logic	131 Periodic Maintenance
87 General	131 General
87 Digital Display	133 Refrigerant Emission Control
93 — Menus	133 Weekly Maintenance
99 — Chiller Switch	134 Monthly Maintenance
100 Menu Function Descriptions and Selection	134 Annual Maintenance
100 — Selecting Variables and Options	135 Maintenance
100 — Menu 0 - Operating Display	135 General
100 — Menu 1 - Service #1 Display	135 Coil Cleaning
101 — Menu 2 - Service #2 Display	135 Chemically Cleaning the Evaporator
101 — Menu 3 - Auxiliary Options	135 Domestic Water Heater – Tube Cleaning
102 — Menu 4 - Factory Display #1	136 Water Treatment
104 — Menu 5 - Factory Display #2	136 Oil Separator Level Check
105 Operational Features	
105 — Entering Evaporator Water Temperature	
105 — Current Limit Setpoint	
105 — Low Ambient Lockout	
105 — Electronic Expansion Valve (EXV) Test	
105 — Current Overload Protection	
105 — Leaving Chilled Water Temperature Control	
106 — Chilled Water Reset (CWR)	
107 — Leaving Water Temperature Cutout	
107 — Low Refrigerant Temperature Cutout	
107 — Low Ambient Temperature Start	
107 — Low Refrigerant Temperature Cutout Retry	
108 — Auto Lead/Lag	
108 — Phase Imbalance Protection	
108 — Reverse Rotation Protection	
108 DIP Switch Settings	
108 Compressor Overload DIP Switches	
108 IPC Address	
108 — 2-10 VDC/4-20 mA Input for (CWS) and (CLS)	
109 Diagnostics and Troubleshooting	
109 —Mechanical Control Settings	

List of Illustrations

- | | |
|--|---|
| <p>11 Figure 1
Typical RTAA Packaged Unit -
130 to 200 Tons (Front/side
Exterior View)</p> <p>12 Figure 2
Typical RTAA Packaged Unit -
130 to 200 Tons (Rear/side Exterior
View)</p> <p>13 Figure 3
Typical RTAA Packaged Unit -
240 to 400 Tons (Front/side
Exterior View)</p> <p>14 Figure 4
Typical RTAA Unit (Rear Exterior
View)</p> <p>15 Figure 5
Typical RTAA Unit with Remote
Evaporator Option (Rear Exterior
View)</p> <p>18 Figure 6
Remote Evaporator</p> <p>21 Figure 7
Nameplates</p> <p>22 Figure 8
Model Number Coding System</p> <p>26 Figure 9
Dimensions and Clearances for
RTAA Packaged Unit
- 130 to 200 Tons</p> <p>27 Figure 10
Dimensions and Clearances for
RTAA Packaged Unit
- 240 to 300 Tons</p> <p>28 Figure 11
Dimensions and Clearances for
RTAA Packaged Unit
- 340 to 400 Tons</p> <p>29 Figure 12
Dimensions and Clearances for
RTAA Outdoor Unit with Remote
Evaporator Option</p> <p>30 Figure 13
Dimensions and Weights for
Remote Evaporator</p> <p>33 Figure 14
Rigging and Lifting Weights for
RTAA Packaged Unit
- 130 to 200 Tons Including
Domestic Water Heater</p> <p>34 Figure 15
Rigging and Lifting Weights for
RTAA Packaged Unit
- 240 to 300 Tons</p> <p>34 Figure 16
Rigging and Lifting Weights for
RTAA Packaged Unit
- 340 to 400 Tons</p> <p>35 Figure 17
Rigging and Lifting Weights for
RTAA Outdoor Unit with Remote
Evaporator Option</p> | <p>37 Figure 18
Spring Isolator Placement for
Typical RTAA Packaged Unit
- 130 to 200 Tons</p> <p>38 Figure 19
Spring Isolator Placement for
Typical RTAA Packaged Unit
-240 to 400 Tons</p> <p>39 Figure 20
Spring Isolator Placement for
Typical RTAA Outdoor Unit with
Remote Evaporator Option</p> <p>40 Figure 21
Spring Isolator Placement for
Typical RTAA Unit with Heat
Recovery Domestic Water Heater</p> <p>41 Figure 22
Suggested Piping for Typical RTAA
Evaporator</p> <p>43 Figure 23
RTAA 130 thru 400 Evaporator
Water Pressure Drop</p> <p>46 Figure 24
Typical Domestic Water Heater
Piping</p> <p>46 Figure 25
RTAA 130 thru 400 Domestic
Water Heater Water Pressure Drop</p> <p>47 Figure 26
Remote Evaporator Installation -
No Elevation Difference</p> <p>48 Figure 27
Remote Evaporator Installation -
Condenser and Compressor above
Evaporator</p> <p>49 Figure 28
Restricted Installation -Evaporator
is More Than 1'8" Above Base of
Outdoor Unit.</p> <p>49 Figure 29
Restricted Installation -Suction
Line is on a Higher Plane than the
Outdoor Unit.</p> <p>50 Figure 30
Refrigerant Circuit Identification</p> <p>52 Figure 31
Remote Evaporator Piping
Example</p> <p>55 Figure 32
Customer Interconnect Wiring for
RTAA Outdoor Unit with Remote
Evaporator -130 to 200 Tons</p> <p>57 Figure 33
Warning Label</p> <p>58 Figure 34
Typical Field Wiring for RTAA
Packaged Unit - 130 to 200 Tons</p> <p>61 Figure 35
Typical Field Wiring for RTAA
Packaged Unit - 240 to 400 Tons</p> |
|--|---|

64	Figure 36 Typical Field Wiring for Outdoor Unit with Remote Evaporator Option	126	Figure 56 Unit Sequence of Operation - 240 to 400 Tons
70	Figure 37 Alarm/Running/Maximum Capacity Contact Outputs	128	Figure 57 Unit Sequence of Operation -130 to 200 Tons
72	Figure 38 Resistor and Potentiometer Arrangement for External Chilled Water Setpoint	132	Figure 58 Operator's Log
73	Figure 39 Resistor and Potentiometer Arrangement for External Current Limit Setpoint	135	Figure 59 Chemical Cleaning Configuration
78	Figure 40 Refrigeration System and Control Components - Single Circuit	137	Figure 60 System Oil Level Specification
80	Figure 41 Refrigeration System and Control Components - Duplex Circuit		
81	Figure 42 Typical RTAA Compressor		
82	Figure 43 RTAA Compressor Oil System Schematic		
83	Figure 44 Oil Separator		
85	Figure 45 Fan Configurations - RTAA 130 to 200 Ton 15 F Minimum Ambient		
86	Figure 46 Fan Configurations - RTAA 130 to 400 Ton 0 F Minimum Ambient		
88	Figure 47 RTAA Control Panel - 130 to 200 Tons		
89	Figure 48 RTAA Control Panel - 240 to 300 Tons		
90	Figure 49 RTAA Control Panel - 340 to 400 Tons		
91	Figure 50 RTAA Control Panel - 130 to 200 Tons with Remote Evaporator Option		
92	Figure 51 Operator Interface Controls		
93	Figure 52 Menu Formats		
98	Figure 53 Condition/Diagnostic Codes		
107	Figure 54 Low Refrigerant Temperature Cutout Ignore Time		
123	Figure 55 Associated Research Model 45 Phase Sequence Indicator		

List of Tables

- 16 Table 1
General RTAA Mechanical
Specifications
- 17 Table 2
RTAA Refrigerant Circuit
Designations and Capacities
- 51 Table 3
RTAA Circuit Capacities
- 51 Table 4
Liquid Line Size for Horizontal and/
or Downflow Lines
- 51 Table 5
Equivalent Lengths of Non-Ferrous
Valves and Fittings
- 53 Table 6
Suction Line Size for Horizontal
and/or Upflow Lines
- 53 Table 7
Suction Line Size for Horizontal
and/or Downflow Lines
- 56 Table 8
System Refrigerant Charge
- 56 Table 9
Field-installed Piping Charge
- 67 Table 10
Electrical Data
- 70 Table 11
Alarm/Running/Maximum
Capacity Relay Output
Configurations
- 70 Table 12
Alarm/Running/Maximum
Capacity Menu Settings
- 72 Table 13
Input Values vs Extended Chilled
Water Setpoint Inputs (Ohms)
- 73 Table 14
Input Values vs External Current
Unit Setpoint
- 102 Table 15
Leaving Fluid Temperature
Setpoints
- 104 Table 16
Compressor Overload DIP Switch
Settings
- 105 Table 17
Compressor(s) Current Limit
Setpoint vs. Chiller Current Limit
Setpoint (CLS)
- 110 Table 18
Diagnostic and Troubleshooting
Chart



General Information

Literature Change History

RTAA-IOM-3 (October 1991)

Original manual. Covers installation, operation, and maintenance of "CO" design sequence RTAA-130 thru RTAA-400 units.

Unit Identification

When the unit arrives, compare all nameplate data with ordering and shipping information.

Unit Inspection

When the unit is delivered, verify that it is the correct unit and that it is properly equipped. Compare the information which appears on the unit nameplate with the ordering and submittal information. Refer to "Nameplates".

Note: If the Remote Evaporator Option is ordered, the remote evaporator will be shipped in a separate crate. The serial number on the evaporator nameplate must match the serial number on the outdoor unit nameplate.

Caution: If the serial numbers on the remote evaporator and the outdoor unit do not match, do not proceed with the installation. Notify the appropriate Trane Sales Office.

Inspect all exterior components for visible damage. Report any apparent damage or material shortage to the carrier and make a "unit damage" notation on the carrier's delivery receipt. Specify the extent and type of damage found and notify the appropriate Trane Sales Office.

Do not proceed with installation of a damaged unit without sales off ice approval.

Inspection Checklist

To protect against loss due to damage incurred in transit, complete the following checklist upon receipt of the unit.

- Inspect the individual pieces of the shipment before accepting the unit. Check for obvious damage to the unit or packing material.
- Inspect the unit for concealed damage as soon as possible after delivery and before it is stored. Concealed damage must be reported within 15 days.
- If concealed damage is discovered, stop unpacking the shipment. Do not remove damaged material from the receiving location. Take photos of the damage, if possible. The owner must provide reasonable evidence that the damage did not occur after delivery.
- Notify the carrier's terminal of the damage immediately, by phone and by mail. Request an immediate, joint inspection of the damage with the carrier and the consignee.
- Notify the Trane sales representative and arrange for repair. Do not repair the unit, however, until damage is inspected by the carrier's representative.

Loose Parts Inventory

Check all the accessories and loose parts which are shipped with the unit against shipping list. Included in these items will be water vessel drain plugs, rigging and electrical diagrams, and service literature, which are placed inside the control panel and/or starter panel for shipment.

Unit Description

The 130 thru 400-ton Model RTAA units are helical-rotary type, air-cooled liquid chillers designed for installation outdoors. Depending upon rated capacity, the unit will have two, three or four compressors. The compressor circuits are completely assembled, hermetic packages that are factory-piped, wired, leak-tested, dehydrated, and tested for proper control operation before shipment.

Note: Packaged units are factory charged with refrigerant and oil. Remote evaporator units are shipped with a holding charge of nitrogen and a partial charge of oil.

Figures 1 thru 4 show typical RTAA packaged units and their components. Figures 5 and 6 show a typical RTAA Remote Evaporator outdoor unit and evaporator. Tables 1 and 2 contain general RTAA mechanical specifications. Chilled water inlet and outlet openings are covered for shipment. Each compressor has a separate compressor motor starter.

The RTAA series features Trane's exclusive Adaptive Control™ logic, which monitors the control variables that govern the operation of the chiller unit. Adaptive Control logic can correct these variables, when necessary, to optimize operational efficiencies, avoid chiller shutdown, and keep producing chilled water. An optional remote display is available to monitor unit operation from a remote location.

These units feature two independent refrigerant circuits. Compressor unloaders are solenoid actuated and oil pressure operated. Each refrigerant circuit is provided with filter drier, sight glass, electronic expansion valve, and charging valves.

The shell-and-tube type evaporator is manufactured in accordance with ASME standards. Each evaporator is fully insulated and is equipped with water drain and vent connections. Packaged units have heat tape protection to -200 F. Remote evaporators do not have heat tape.

Commonly Used Acronyms

Acronyms used in this manual are defined below.

OAT =	Outdoor Air Temperature
BAS =	Building Automation System
BCL =	Bidirectional Communications Link
CAR =	Circuit Shutdown, Auto Reset
CLS =	Current Limit Setpoint
CMR =	Circuit Shutdown, Manual Reset
CWR =	Chilled Water Reset
CWS =	Chilled Water Setpoint
DDT =	Design Delta-Temperature Setpoint (i.e., the difference between entering and leaving chilled water temperatures)
ENT =	Entering Chilled Water Temperature
EXV =	Electronic Expansion Valve
FLA =	Full Load Amps
HGBP =	Hot Gas Bypass
HVAC =	Heating, Ventilating and Air Conditioning
IFW =	Informational - Warning I/O Input and Output Wiring
IPC =	Inter-Processor Communications
LRA =	Locked Rotor Amps Leaving Chilled Water Temperature
MAR =	Machine Shutdown, Auto Reset
MMR =	Machine Shutdown, Manual Reset
NEC =	National Electric Code
PCWS =	Front Panel Chilled Water Setpoint
PFCC =	Power Factor Correction Capacitors
PSID =	Pounds-per-Square-inch Differential (pressure differential)
PSIG =	Pounds-per-Square-inch (gauge pressure)
RAS =	Reset Action Setpoint
RLA =	Rated Load Amps
RCWS =	Reset Chilled Water Setpoint (CWR)
RRS =	Reset Reference Setpoint (CWR)
SV =	Slide Valve
Tracer® =	Type of Trane Building Automation System
SCI =	Serial Communications Interface
UCLS =	Unit Current Limit Setpoint
UCM =	Unit Control Module (Microprocessor-based)
UCWS =	Unit Chilled Water Setpoint

Figure 1
Typical RTAA Packaged Unit
130 - 200 Ton
(Front/Side Exterior View)

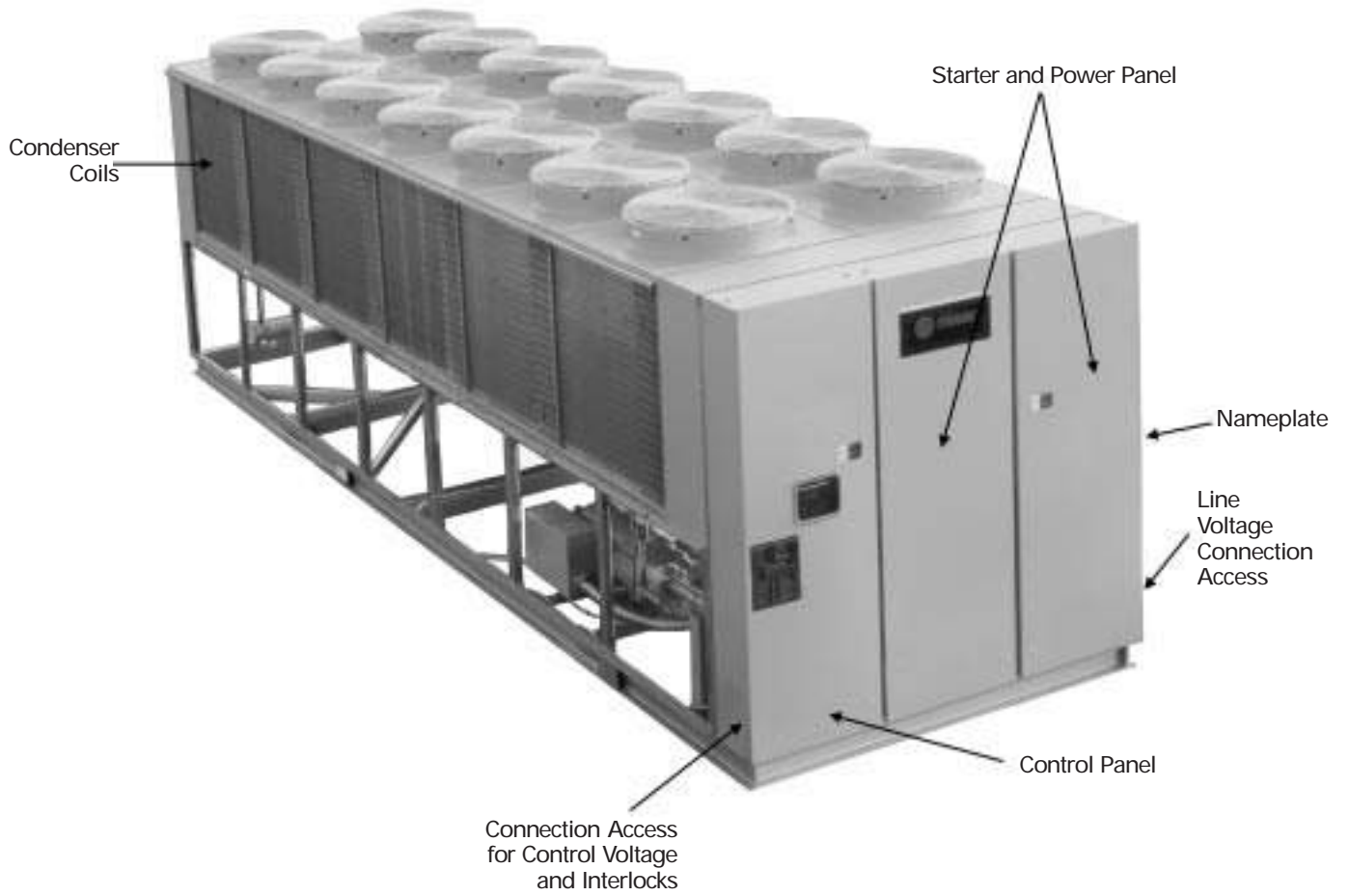

Figure 2
Typical RTAA Packaged Unit
130 - 200 Ton
(Rear/Side Exterior View)

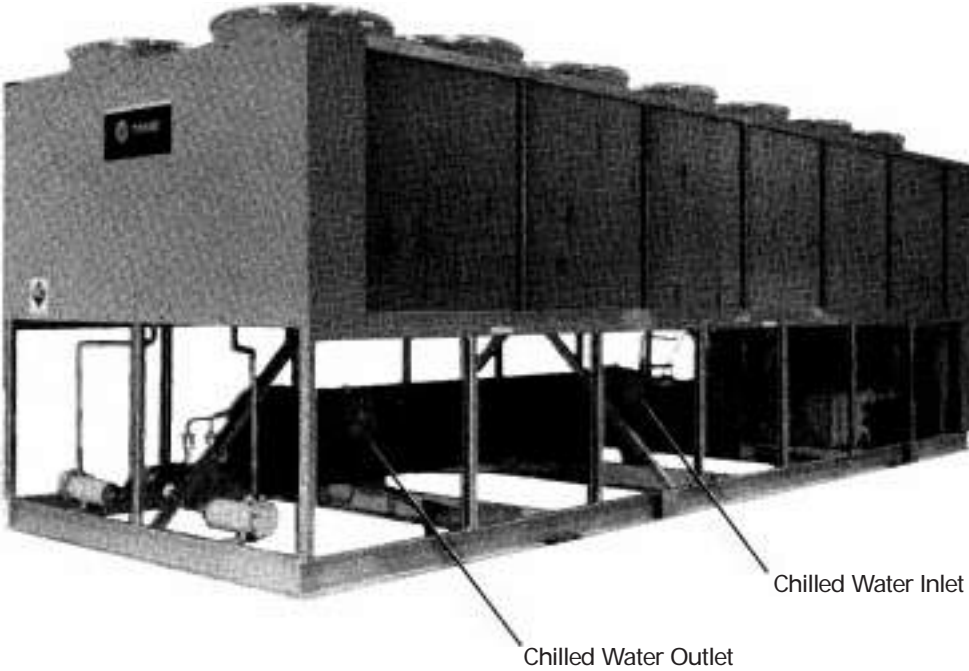

Figure 3
Typical RTAA Packaged Unit
240-400 Tons

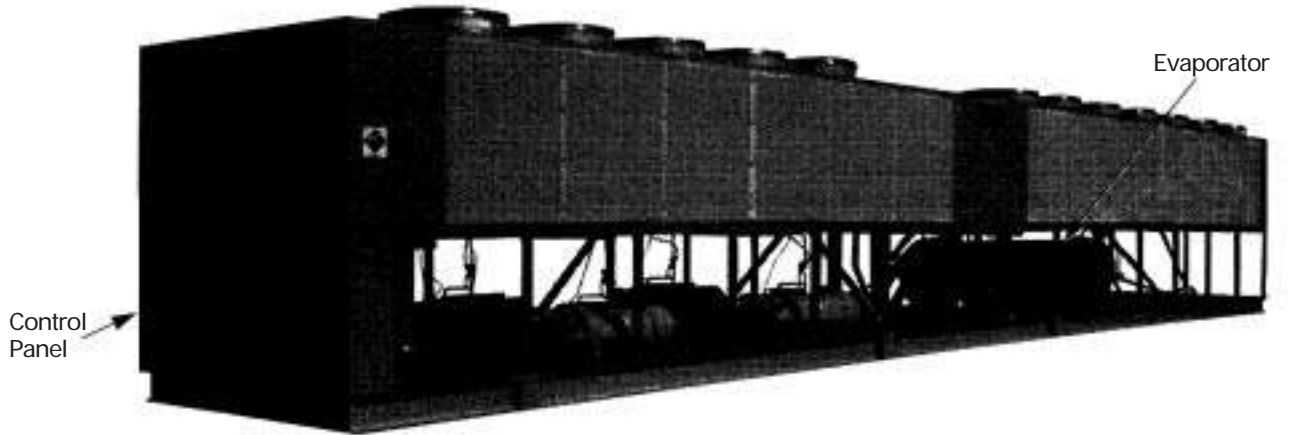

Figure 4
Typical RTAA Unit
(Rear Exterior View)

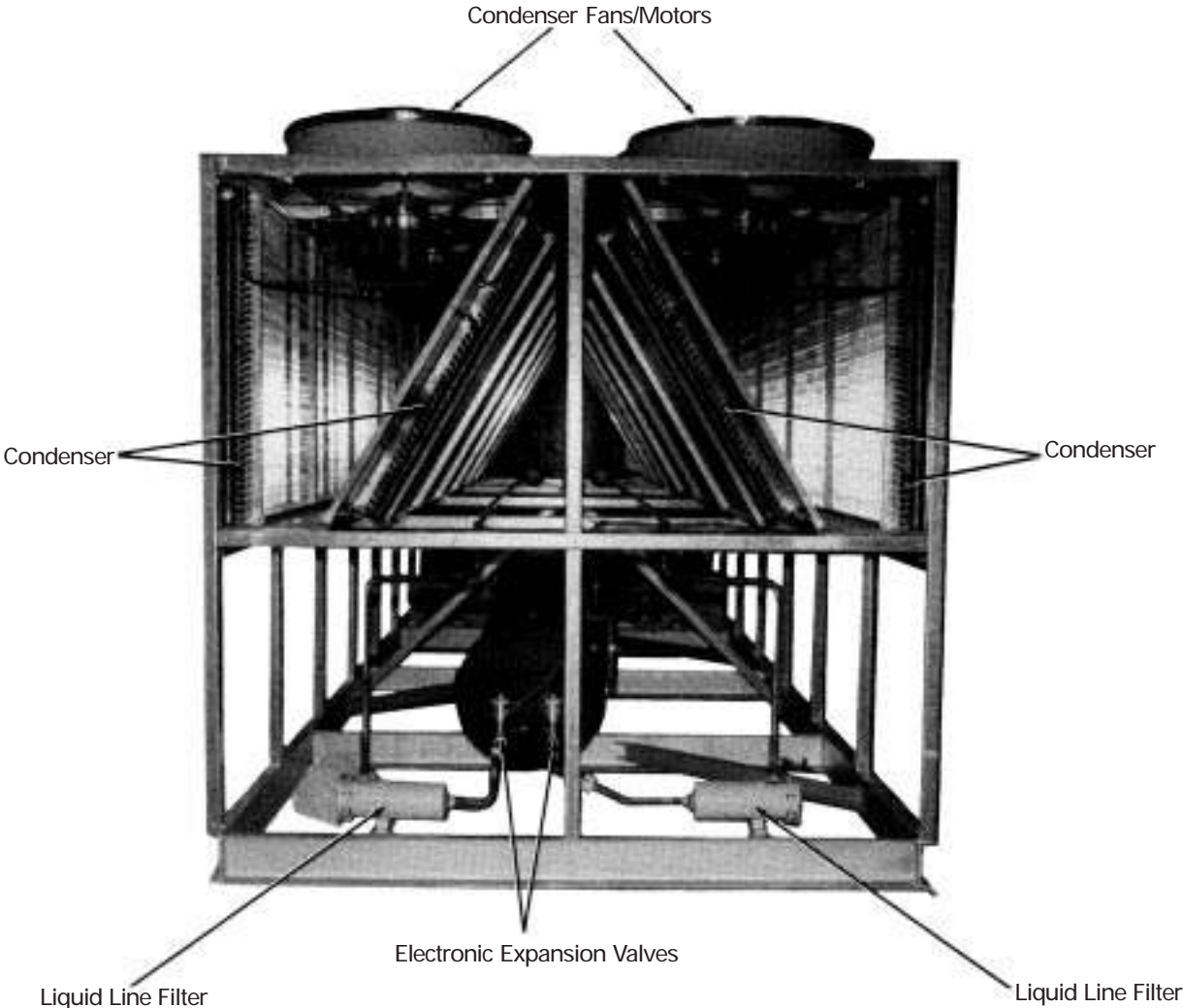

Figure 5
Typical RTAA Unit
(with Remote Evaporator Option)
(Rear Exterior View)

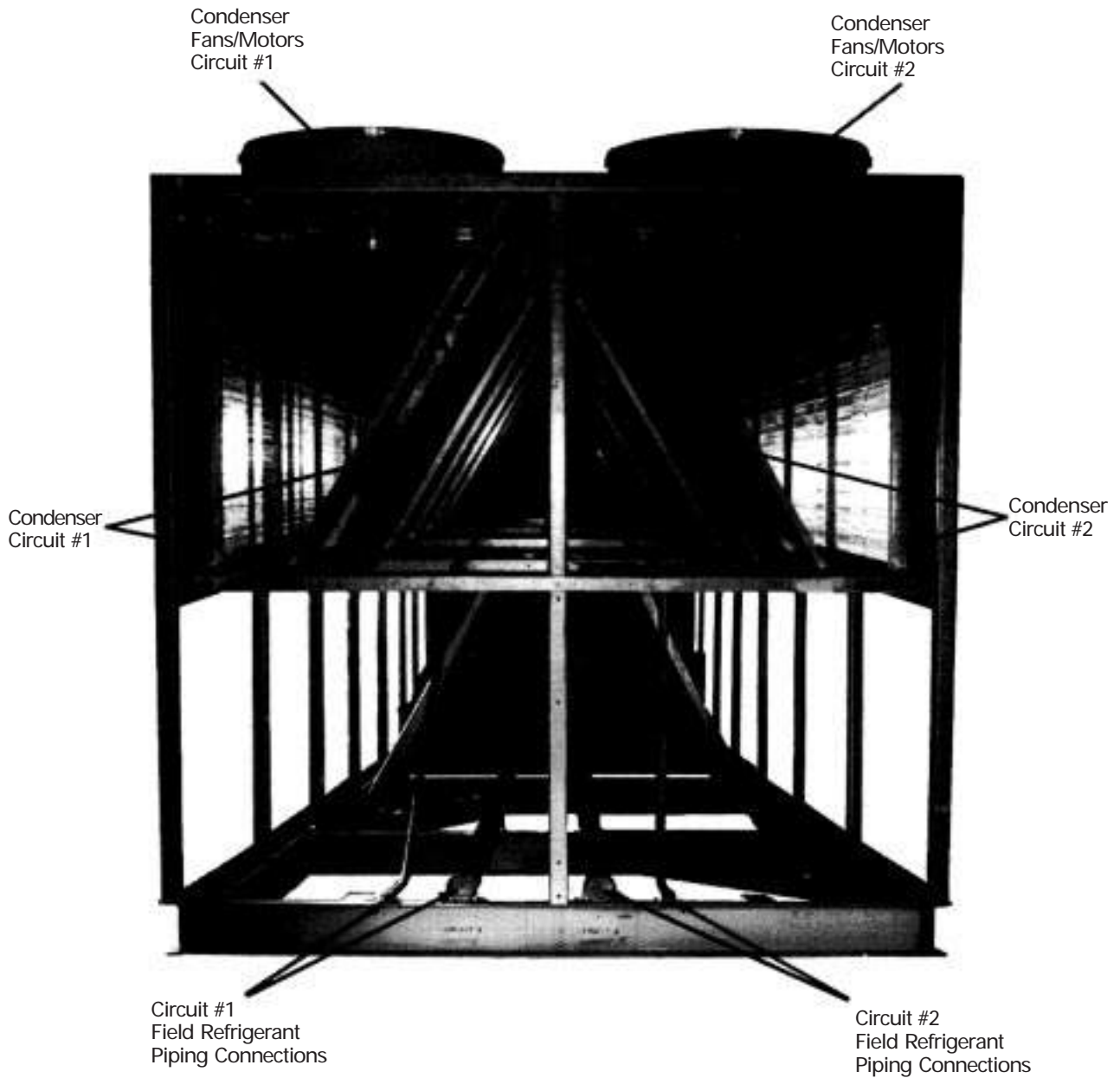

Table 1
General RTAA Mechanical Specifications

	Size					
	130	140	155	170	185	200
Compressor						
Quantity	2	2	2	2	2	2
Nominal Size(1)(Tons)	70/70	70/70	85/70	100/70	100/85	100/100
Evaporator						
Water Storage (Gallons)	49	46	73	69	62	61
(Liters)	184	175	277	261	234	231
Min. Flow (GPM)	156	156	186	186	222	222
(L/Sec)	9.8	9.8	11.7	11.7	14.0	14.0
Max. Flow (GPM)	504	504	612	612	720	720
(L/Sec)	31.8	31.8	38.6	38.6	45.4	45.4
Condenser						
Oty of Coils	4	4	4	4	4	4
Coil Length (In)	214/214	214/214	240/214	240/214	240/240	240/240
Coil Height (In)	42	42	42	42	42	42
Number of Rows	3	3	3	3	3	3
Condenser Fans						
Quantity	5/5	5/5	6/5	7/5	7/6	7/7
Diameter (In)	30	30	30	30	30	30
Total Airflow (CFM)	105,860	105,860	114,610	120,160	128,910	134,460
Nominal RPM	1140	1140	1140	1140	1140	1140
Tip Speed (Ft/Min)	8954	8954	8954	8954	8954	8954
Motor HP (Ea)	1.5	1.5	1.5	1.5	1.5	1.5
Min Starting/Oper. Ambient (2)						
Std Unit (Deg. F)	15	15	15	15	15	15
Low Amb. (Deg. F)	0	0	0	0	0	0
General Unit						
Refrigerant	HCFC-22	HCFC-22	HCFC-22	HCFC-22	HCFC-22	HCFC-22
No. of Independent Refrigerant Circuits	2	2	2	2	2	2
% Min. Load (3)	10	10	10	10	10	10
Refrig. Charge(1)(Lb)	130/130	130/130	165/130	170/130	170/165	170/170
(Kg)	59/59	59/59	75/59	77/59	77/75	77/77
Oil Charge (Gal)	7/7	7/7	8/7	8/7	8/8	8/8
(1,4,5) (L)	27/27	27/27	31/27	31/27	31/31	31/31

Table 1 (Continued from previous page)
General RTAA Mechanical Specifications

	Size					
	240	270	300	340	370	400
Compressor						
Quantity (1)	2/1	1-1/1	2/1	2/2	1-1/2	2/2
Nominal Size (1)(Tons)	70/100	100-70/100	100/100	70/100	100-70/100	100/100
Evaporator						
Water Storage (Gallons)	151	143	135	124	116	108
(Liters)	572	523	511	470	439	407
Min. Flow (GPM)	288	288	288	408	408	408
(L/Sec)	18.2	18.2	18.2	25.7	25.7	25.7
Max. Flow (GPM)	1080	1080	1080	1440	1440	1440
(L/Sec)	68.1	68.1	68.1	90.8	90.8	90.8
Condenser						
Qty. of Coils	4/4	2-2/4	4/4	4/4	2-2/4	4/4
Coil Length (In)	214/120	240-214/120	240/120	214/240	240-214/240	240/240
Coil Height (In)	42	42	42	42	42	42
Number of Rows	3	3	3	3	3	3
Condenser Fans						
Quantity (1)	10/7	12/7	14/7	10/14	12/14	14/14
Diameter (In)	30	30	30	30	1 30	30
Total Airflow (CFM)	173,090	187,390	201,690	240,320	254,620	268,920
Nominal RPM	1140	1140	1140	1140	1140	1140
Tip Speed (Ft/Min)	8954	8954	8954	8954	8954	8954
Motor HP (Ea)	1.5	1.5	1.5	1.5	1.5	1.5
Min Starting/Oper. Ambient (2) (Deg. F)	0	0	0	0	0	0
General Unit						
Refrigerant	HCFC-22	HCFC-22	HCFC-22	HCFC-22	HCFC-22	HCFC-22
No. of Independent Refrigerant Circuits	2	2	2	2	2	2
% Min. Load (3)	10	10	10	10	10	10
Refrig Charge(1)(Lb)	276/180	318/180	360/180	276/360	318/360	360/360
(Kg)	125/82	144/82	163/82	125/163	144/163	163/163
Oil Charge) (Gal)	15/8	16/8	17/8	15/17	16/17	17/17
(1.4,5) (L)	57/31	61/31	65/31	57/65	61/65	65/65

Notes:

- (1) Data containing information on two circuits shown as follows: ckt1/ckt2
- (2) Minimum start-up/operating ambient based on a 5 mph wind across the condenser.
- (3) Percent minimum load is for total machine, not each individual circuit.
- (4) Trane Part# OIL-15
- (5) Add 6 gal./circuit for domestic water heater.

Figure 6
Remote Evaporator

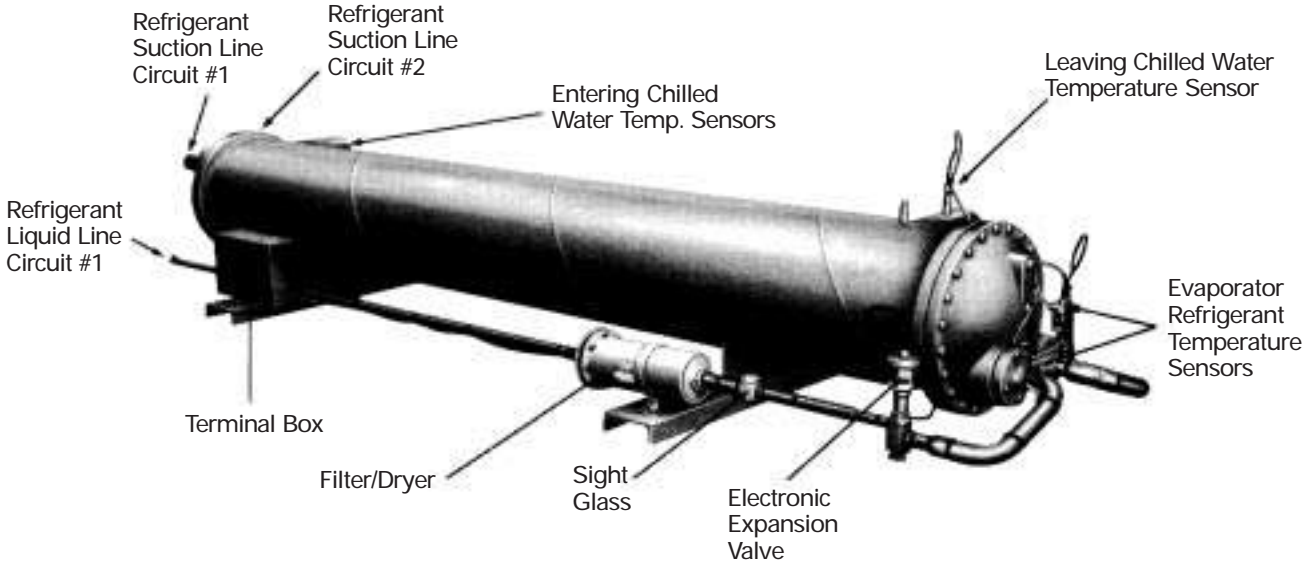
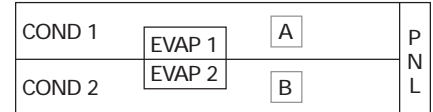

Table 2
RTAA Refrigerant Circuit Designations and Capacities

RTAA Model	Circuit/Tons		Compressor/Tons	
130	1	70	A	70
	2	70	B	70
140	1	70	A	70
	2	70	B	70
155	1	85	A	85
	2	70	B	70
170	1	100	A	100
	2	70	B	70
185	1	100	A	100
	2	85	B	85
200	1	100	A	101
	2	100	B	100

Package Unit 130-200



Remote Evaporator Unit 130-200

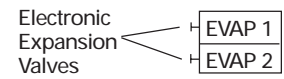

RTAA Model	Circuit/Tons		Compressor/Tons	
240	1	140	A	70
			B	70
			C	100
270	1	170	A	100
			B	70
			C	100
300	1	200	A	100
			B	100
			C	100
340	1	140	A	70
			B	70
			C	100
370	1	170	A	100
			B	70
			C	100
			D	100
400	1	200	A	100
			B	100
			C	100
			D	100

240-300

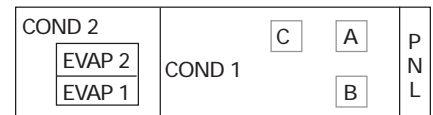

340-400

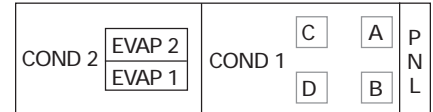

Warnings and Cautions

Warnings and Cautions appear in boldface type at appropriate points in this manual.

Warnings are provided to alert personnel to potential hazards that can result in personal injury or death; they do not replace the manufacturer's recommendations.

Cautions alert personnel to conditions that could result in equipment damage.

Your personal safety and reliable operation of this machine depend upon strict observance of these precautions. The Trane Company assumes no liability for installation or service procedures performed by unqualified personnel.

Installation Responsibilities

Generally, the contractor must do the following when installing an RTAA unit:

- [] Install unit on a flat foundation, level (within 1/4" [6.4 mm]), and strong enough to support unit loading.
- [] Install unit per the instructions contained in the Installation Mechanical and Installation Electrical sections of this manual.
- [] Install any optional sensors and make electrical connections at the UCM.

Note: The standard leaving chilled water sensor is factory installed in the evaporator leaving water outlet.

- [] Where specified, provide and install valves in water piping upstream and downstream of evaporator water connections to isolate the evaporator for maintenance, and to balance/trim system.

- [] If desired, supply and install flow switches in the chilled water piping; interlock each switch with proper pump starter to ensure unit can only operate if water flow is established. Chilled water flow protection is provided by the UCM without the need for a chilled water flow switch. A flow switch for chilled water is strictly discretionary.

- [] **For Remote Evaporator units only,** furnish and install refrigerant piping, refrigerant and oil, per the instructions outlined in this manual.

- [] Furnish and install pressure gauges in inlet and outlet piping of the evaporator.

- [] Furnish and install a drain valve to the bottom of the evaporator.

- [] Supply and install a vent cock to the top of the evaporator.

- [] Where specified, furnish and install strainers ahead of all pumps and automatic modulating valves.

- [] Provide and install field wiring.

- [] Start unit under supervision of a qualified service technician.

- [] Install heat tape and insulate the chilled water lines and any other portions of the system, as required, to prevent sweating under normal operating conditions or freezing during low ambient temperature conditions.

Nameplates

The RTAA outdoor unit nameplates are applied to the exterior and interior surface of the Control Panel door (Figure 1). A compressor nameplate is located on each compressor. On remote evaporators, the nameplate is located on the Terminal Box.

Outdoor Unit Nameplate

The outdoor unit nameplate provides the following information:

- Unit model and size description.
- Unit serial number.
- Identifies unit electrical requirements.

- Lists correct operating charges of R-22 and refrigerant oil.
- Lists unit test pressures.
- Identifies installation, operation and maintenance and service data literature
- Lists drawing numbers for unit wiring diagrams.

Compressor Nameplate

The "compressor" nameplate provides following information:

- Compressor model number.
- Compressor serial number.

- Compressor electrical characteristics.
- Utilization Range.
- Recommended refrigerant.

Remote Evaporator Nameplate

The "evaporator" nameplate provides the following information:

- RTAA outdoor unit to which the remote evaporator is designed to be connected.
- Evaporator serial number. This number and the serial number of the outdoor RTAA unit to which it is connected will be identical.

Figure 7
Nameplates

TRANE™

**** SERIES 8 AIR COOLED CHILLER ****
FOR OUTDOOR USE

MODEL NO: SERIAL NO: DEVICE NO:

RATED VOLTAGE: VOLTS: 3 PH 3E
VOLTAGE UTILIZATION RANGE: VAC

MINIMUM CIRCUIT AMPCACITY: AMPS (CIRCUIT 1) AMPS (CIRCUIT 2)
RECOMMENDED DUAL ELEMENT FUSE: AMPS (CIRCUIT 1) AMPS (CIRCUIT 2)
MAXIMUM FUSE: AMPS (CIRCUIT 1) AMPS (CIRCUIT 2)
MAXIMUM CIRCUIT BREAKER: AMPS (CIRCUIT 1) AMPS (CIRCUIT 2)
-- CANADIAN INSTALLATION (CEA) ONLY --

	QTY	VOLTS	PH	3E	RLA	LRA
COMPRESSOR MOTOR 1:						
COMPRESSOR MOTOR 2:						
CONDENSER FAN MOTORS:					FLA(FA):	SP(FA):
CONTROL CIRCUIT:					VA MAX:	
EVAPORATOR HEAT TAPE:					VA MAX:	

REFRIGERANT SYSTEM FACTORY CHARGED WITH REFRIGERANT R-22
CIRCUIT 1: LBS. CIRCUIT 2: LBS.

LUBRICATION SYSTEM FACTORY CHARGED WITH TRANE OIL NO. 15
CIRCUIT 1: GALS. CIRCUIT 2: GALS.

MAXIMUM REFRIG. WORKING PRESSURE: PSIG (HIGH) PSIG (LOW)
REFRIG. SIDE FACTORY TEST PRESSURE: 450 PSIG (HIGH) 300 PSIG (LOW)

FOR SERVICE INFORMATION REFER TO THE FOLLOWING TRANE LITERATURE:
INSTALLATION, OPERATION & MAINTENANCE: RTAA-IOM-1
WIRING INFORMATION: STAA-F-1
WIRING DIAGRAMS Page 1:
Page 2:
Page 3:
Page 4:
Page 5:
FIELD WIRING:
COMPONENT LOCATION:

MANUFACTURED UNDER ONE OR MORE OF THE FOLLOWING U.S. PATENTS/
CORRESPONDING FOREIGN PATENTS OWNED BY AMERICAN STANDARD INC.:
4,643,654 2,809,547 4,609,967 4,715,190 4,751,653

THE TRANE COMPANY, COMMERCIAL SYSTEMS GROUP LA CROSSE WISCONSIN 54601
A DIVISION OF AMERICAN STANDARD INC. MADE IN U.S.A.

TRANE™

HELIXROTOR™
COMPRESSOR

MODEL NUMBER

SERIAL NUMBER

ELECTRICAL CHARACTERISTICS

L. R. AMPS

UTILIZATION RANGE

USE TRANE APPROVED OILS

REFRIGERANT

MANUFACTURED UNDER THE FOLLOWING U.S. PATENT: 4,843,654

The Trane Company, La Crosse WI 54601-7000 Made in U.S.A. #39270206-01

REMOTE EVAPORATOR

FOR USE WITH TRANE
MODEL INDICATED BELOW

- RTAA 130
- RTAA 140
- RTAA 155
- RTAA 170
- RTAA 185
- RTAA 200

SERIAL NUMBER

COMM-41

Model Number Coding System

The model numbers for the outdoor unit and the compressors are comprised of numbers and letter which represent features of the equipment. Shown on the chart in Figure 8 are samples of typical unit and compressor model numbers, followed by the coding system for each.

Each position, or group of positions, in the number is used to represent a feature. For example, in Figure 8, position 08 of the unit model number, Unit Voltage, contains the letter "G".

From the chart, it can be seen that a "G" in this position means that the unit voltage is 200-230/60/3 dual voltage.

**Figure 8
Model Number Coding System**

RTA	A	200	G	X	B0	1	A	0	D	0	B	D	E	G
0					1									2
123	4	567	8	9	01	2	3	4	5	6	7	8	9	0

(Digit position for above)

Where digits are assigned the following meanings:

Digit No.	Character Value	Description	Digit No.	Character Value	Description
1, 2, 3	RTA	Unit Type/Function Rotary (Series "R") Air Cooled Chiller	14		Agency Listing
				0	No agency listing
				1	U.L. listed - Standard where applicable
4	A	Development Sequence "A" Dev. Sequence		2	C.S.A. listed
				3	*U.L./C.S.A. listed
5, 6, 7		Unit Nominal Tons		S	Special Customer Option
	130	130 Tons			
	140	140 Tons	15		Control Interface
	155	155 Tons		A	Standard Control No communication module
	170	170 Tons		B	Standard Control With communication module
	185	185 Tons		C	Deluxe Control No communication module
	200	200 Tons		D	Deluxe Control With communication module
	240	240 Tons			Deluxe control option consists of the following:
	270	270 Tons		A -	Cycle counter and hour meter
	300	300 Tons		B -	Under/over voltage protection
	340	340 Tons		C -	Remote alarm contacts and compressor run indication
	370	370 Tons		D -	% volts
	400	400 Tons			
8		Unit Voltage	16		Chilled Water Reset
	D	380/60/3		0	None
	G	200-230/60/3 Dual Voltage		1	Return water temperature
	1	346/50/3		2	Outside air temperature
	K	380-415/50/3		3	Zone temperature
	4	460/60/3		S	Special Customer Option
	5	575/60/3			
	S	Special Customer Option	17+		Add on Options
9		Compressor Starter Type		A	Architectural louvered panels
	Y	Y-Delta (Closed Transition)		B	Control power transformer
	X	X-Line (Across the line)		C	Heat recovery
	S	Special Customer Option		D	Low ambient lockout sensor
10, 11		Design Sequence		E	Suction service valves
	BO	Second design. Increment when parts are affected for service purposes.		F	Power disconnect
				G	Low ambient operation
12		Evaporator Leaving Temp.		H	*Unit sound attenuator
	1	Standard 40-60 F		I	Remote evaporator
	2	Low 20-40 F		S	Special Customer Option
	3	Ice making 20-60 F			
	S	Special Customer Option			
13		Condenser Coil Fin Material			
	A	Aluminum			
	B	Aluminum with corrosion protection			
	S	Special Customer Option			

Note:

1. Digits 17 and on may be multiple, independent add on options.
2. * Denotes that this option assignment has been made but is not available now

Storage

Extended storage of the outdoor unit prior to installation requires the following precautionary measures:

1. Store the outdoor unit in a secure area.
2. At least every three months (quarterly), check the pressure in the refrigerant circuits to verify that the refrigerant charge is intact. If it is not, contact a qualified service organization and the appropriate Trane sales office.



Installation - Mechanical Packaged Unit and Units with Remote Evaporator Option

General

The following instructions are, for the most part, applicable to both packaged units and units with the remote evaporator option. Specific exceptions are noted.

The most significant difference in the installation of the two systems is the requirement for interconnecting piping with the remote evaporator option. For this reason, these installation procedures are covered separately in the following section, Installation - Mechanical, Remote Evaporator Interconnecting Piping.

Pre-installation

Report any damage incurred during handling or installation to the Trane sales office immediately. An Installation Check Sheet is provided.

Location Requirements

Noise Considerations

Locate the outdoor unit away from sound sensitive areas. If required, install rubber vibration isolators in all water piping and use flexible electrical conduit. Refer to "Unit Isolation". Consult an acoustical engineer for critical applications. Also refer to Trane Engineering Bulletins for application information on RTAA chillers.

Foundation

Provide rigid, non-warping mounting pads or a concrete foundation of sufficient strength and mass to support the outdoor unit operating weight (i.e., including completed piping, and full operating charges of refrigerant, oil and water). Refer to Figures 18 thru 21 for unit operating weights. Once in place, the outdoor unit must be level within 1/4" (6.4 mm) over its length and width. The Trane Company is not responsible for equipment problems resulting from an improperly designed or constructed foundation.

Clearances

Provide enough space around the outdoor unit to allow the installation and maintenance personnel unrestricted access to all service points. Refer to submittal drawings for the unit dimensions. A minimum of four feet is recommended for compressor service. Provide sufficient clearance for the opening of control panel doors. Refer to Figures 9 thru 12 for minimum clearances. In all cases, local codes which require additional clearances will take precedence over these recommendations.

Note: If the outdoor unit configuration requires a variance to the clearance dimensions, contact your Trane Sales Office Representative. Also refer to Trane Engineering Bulletins for application information on RTAA chillers.

Figure 9
Dimensions and Clearances for
RTAA Packaged Unit – 130 to 200 Ton

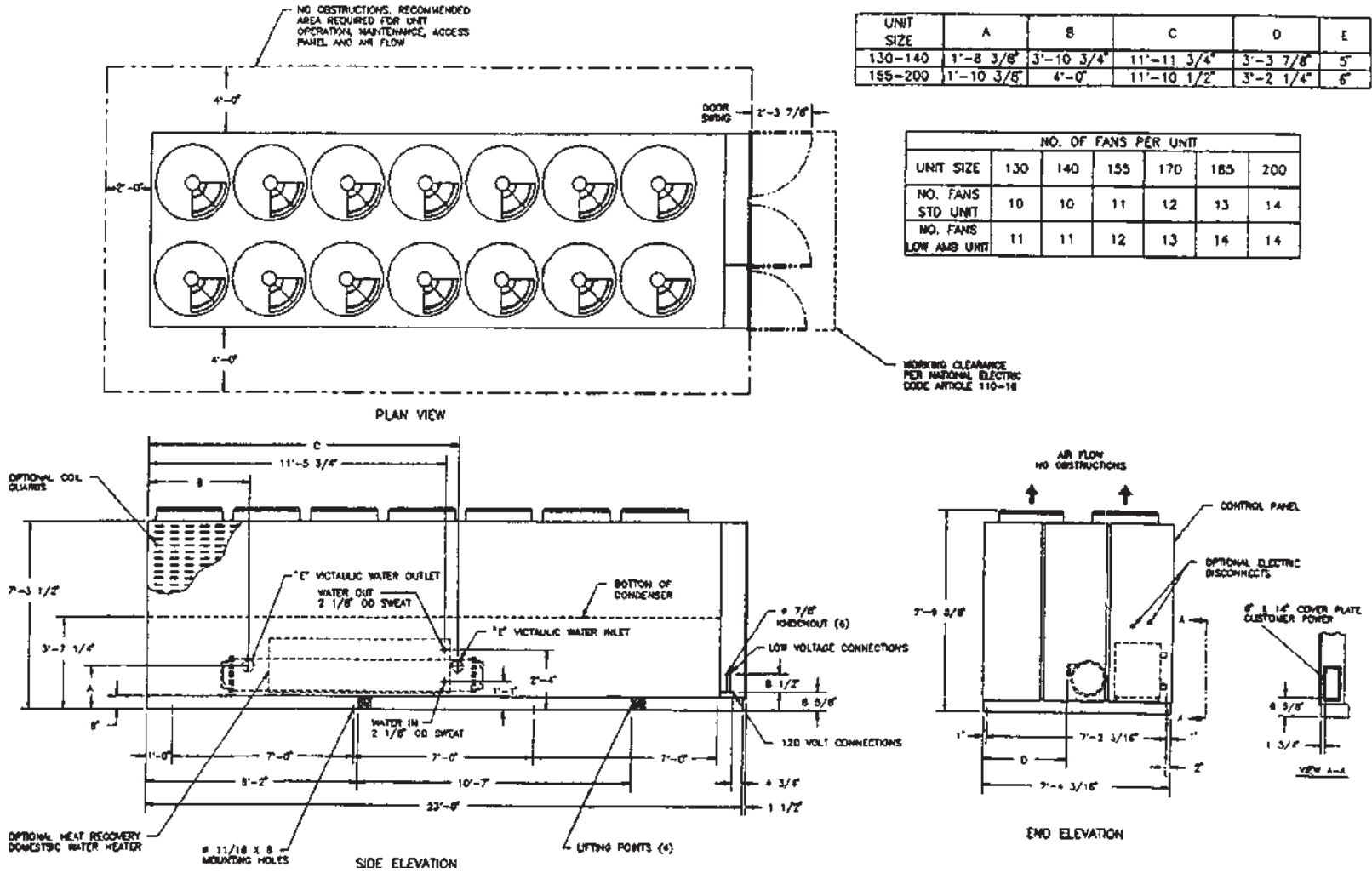

Figure 10
 Dimensions and Clearances for
 RTAA Packaged Unit – 240 - 300 Ton

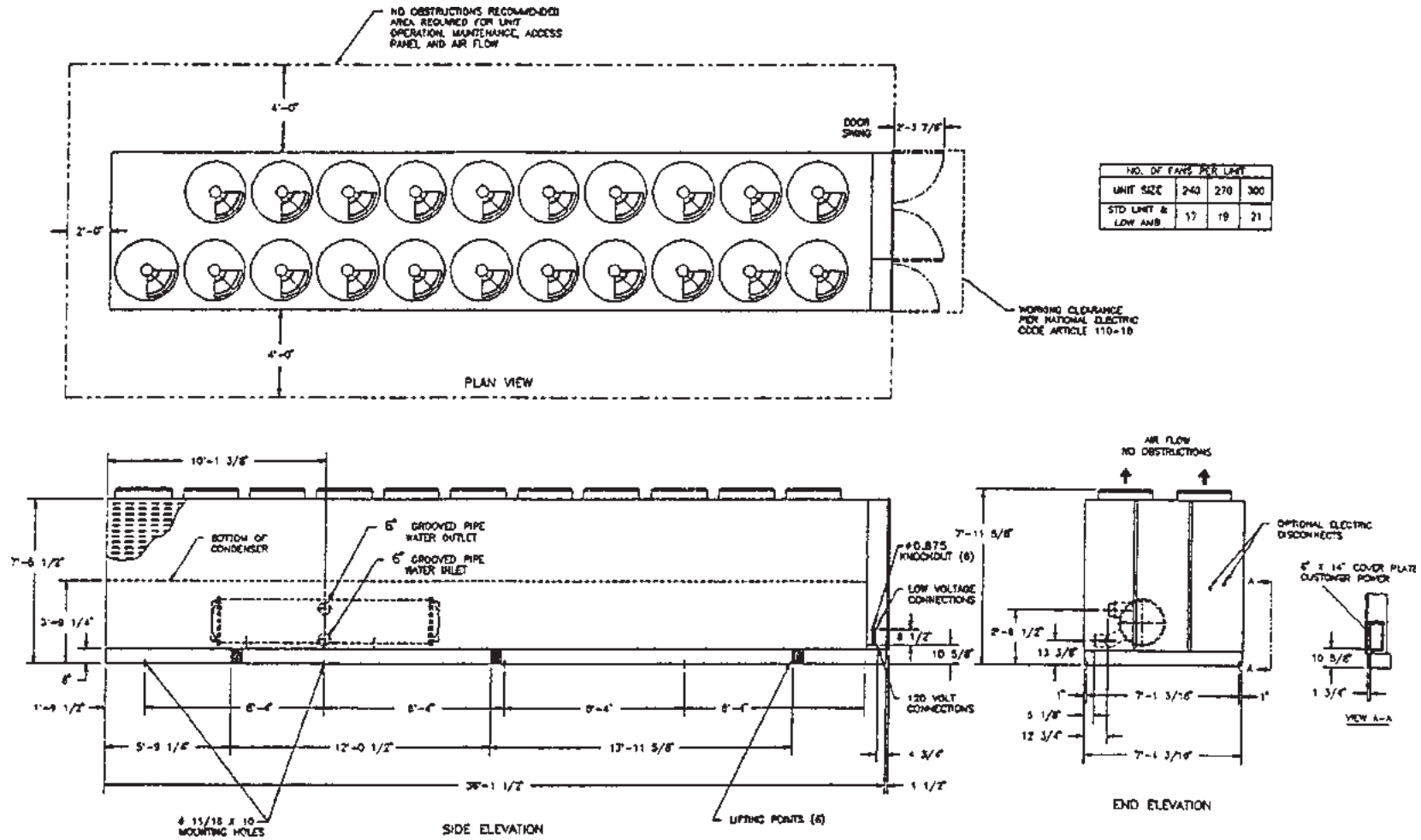

Figure 11
 Dimensions and Clearances for
 RTAA Packaged Unit – 340 to 400 Ton

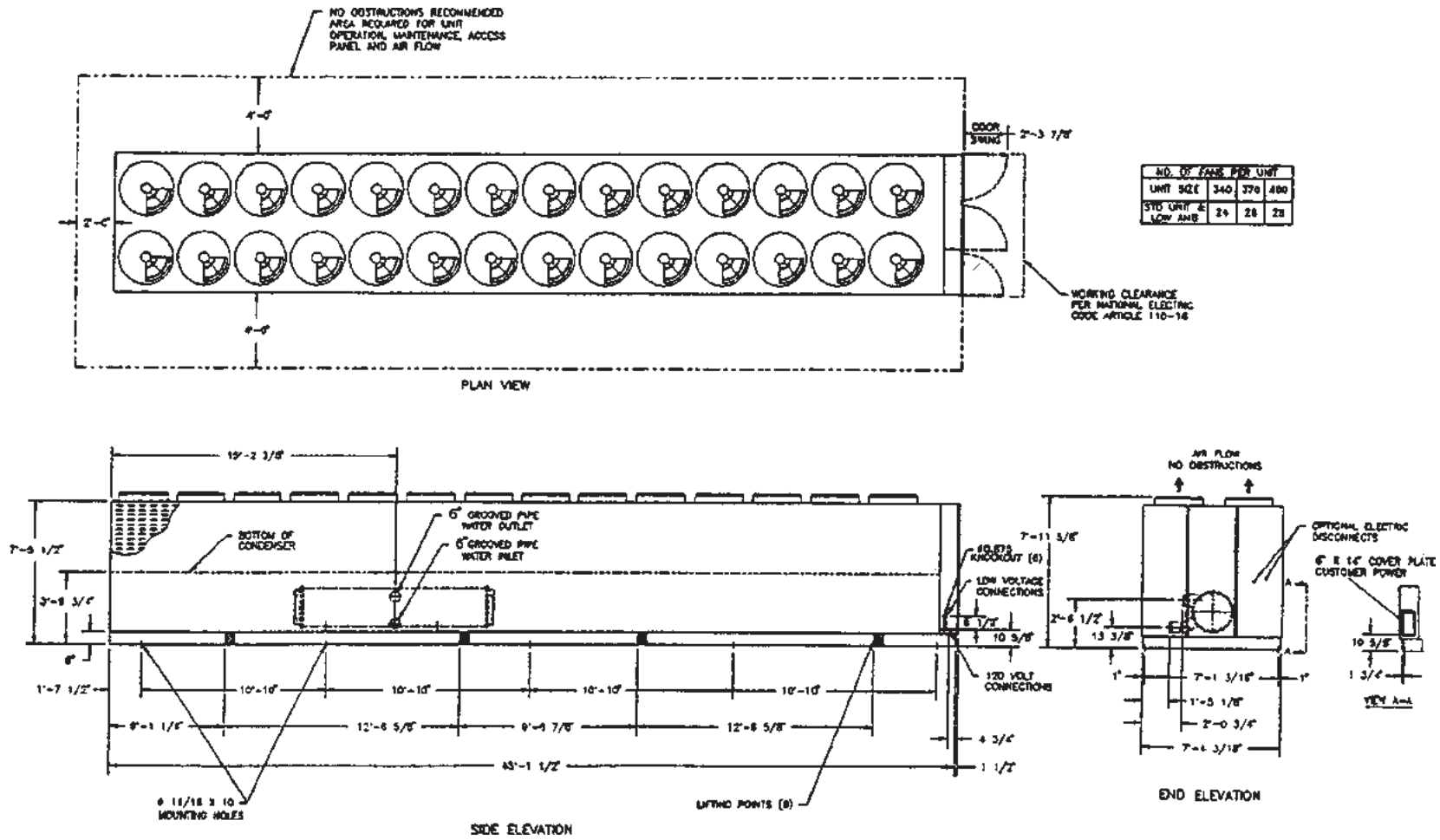

Figure 12
 Dimensions and Clearances for
 RTAA Outdoor Unit with Remote Evaporator Option

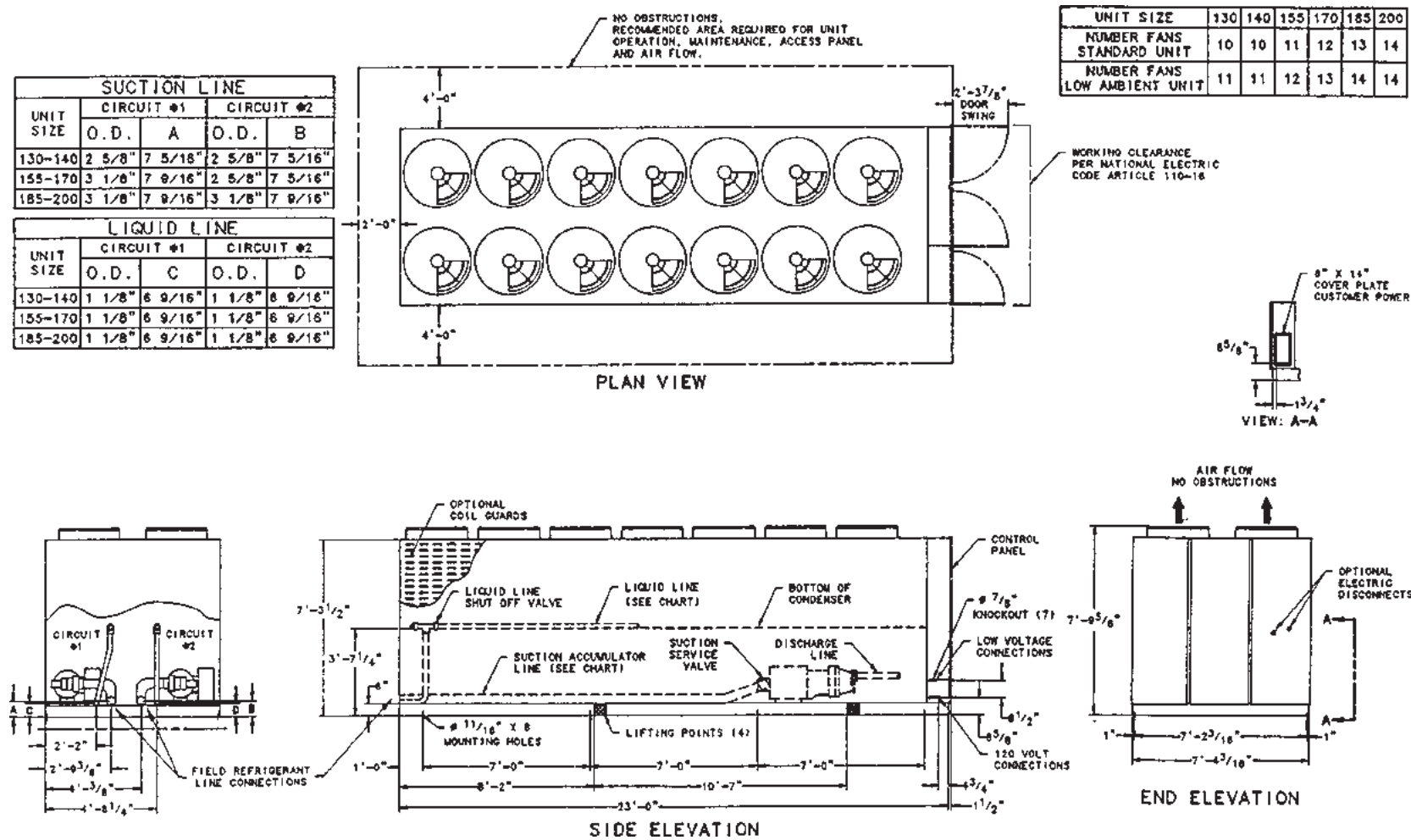

Figure 13
Dimensions and Weights for
Remote Evaporator Option

UNIT SIZE	SUCTION CONNECTIONS		LIQUID LINE CONNECTIONS	
	CIRCUIT #1 O.D.	CIRCUIT #2 O.D.	CIRCUIT #1 O.D.	CIRCUIT #2 O.D.
130-140	2 5/8"	2 5/8"	1 1/8"	1 1/8"
155-170	3 1/8"	2 5/8"	1 1/8"	1 1/8"
185-200	3 1/8"	3 1/8"	1 1/8"	1 1/8"



UNIT SIZE	OPERATING WEIGHT AT MOUNTING LOCATIONS				TOTAL OPERATING WEIGHT	TOTAL SHIPPING WEIGHT
	LOCATION 1	LOCATION 2	LOCATION 3	LOCATION 4		
130	515	488	391	370	1764	1686
140	518	491	394	373	1776	1718
155	649	614	503	476	2242	1944
170	658	620	509	481	2266	2000
185	665	629	517	489	2300	2052
200	672	636	522	494	2324	2103

UNIT SIZE	A	B	C	D	E	F	G	H	J	K NPS
130-140	11'-7 3/8"	1'-8 3/4"	2'-5 3/8"	1'-4"	2 5/8"	8' 1"	11 3/16"	1'-6 3/8"	10"	5"
155-200	11'-9 1/2"	1'-11 3/8"	2'-6 1/2"	1'-5 5/8"	3 5/8"	8'-10 5/8"	10"	1'-6 3/8"	11 5/8"	6"

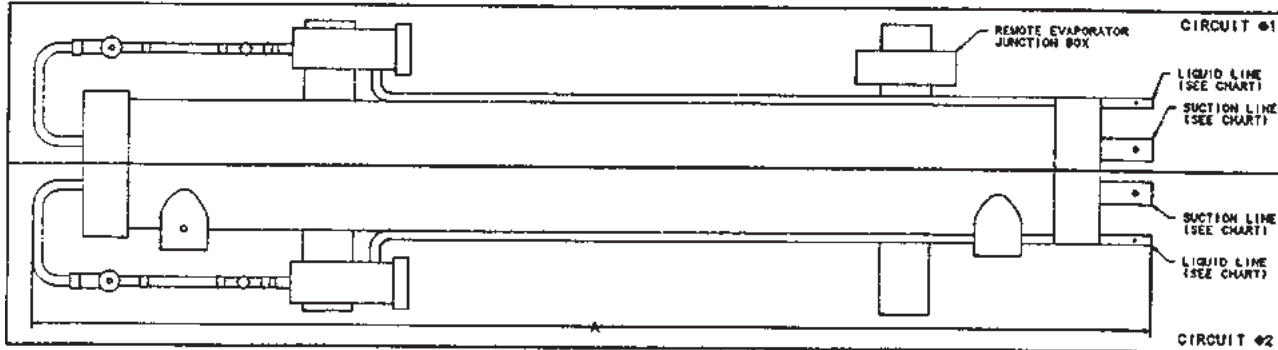

PLAN VIEW

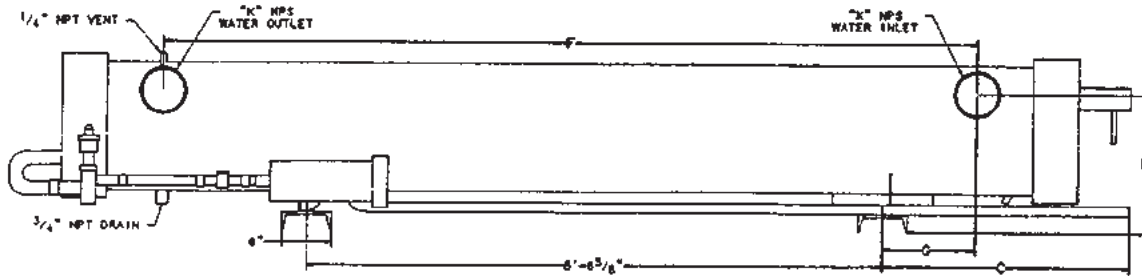

SIDE ELEVATION

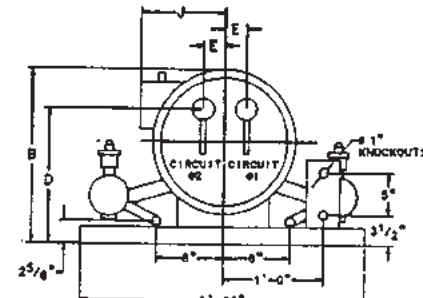

END ELEVATION

NOTES:

1. TOLERANCE ± 1/8" UNLESS OTHERWISE SPECIFIED.
2. ALLOW 8'-8" ON EITHER END FOR TUBE REMOVAL.

Additional Location Requirements for Remote Evaporator Only

The remote evaporator must be installed indoors, unless:

- ambient temperatures are always above 32 F.
- the system circulating liquid is a non-freezing glycol-type solution, selected for the prevailing ambient temperatures.
- the evaporator is protected from freezing by properly installed and applied insulation and heat tape.

Caution: To prevent internal damage due to freezing, do not install the outdoor unit without adequate freeze protection.

The remote evaporator should be mounted on a base of suitable strength to support the operating weight. Remote evaporator weights and mounting locations are shown in Figure 13.

The remote evaporator must be level when installed. Be sure to allow

adequate clearance for water and refrigerant piping connections, performance of service procedures, reading of gauges and thermometers, and operation of valves. Space must be allowed at one end of the evaporator to pull tubes, if required.

Drainage

Provide a large capacity drain for water vessel drain-down during shutdown or repair. The evaporator is provided with a drain connection. Refer to "Evaporator Drain". All local and national codes apply. The vent on the top of the evaporator is provided to prevent a vacuum by allowing air into the evaporator for complete drainage.

Rigging

The Model RTAA chiller should be moved by lifting. Refer to Figures 14 thru 17 for typical unit lifting and operating weights. Refer to the rigging diagram that ships with each unit for specific "per unit" weight data.

WARNING: To prevent injury or death and unit damage, capacity of lifting equipment must exceed unit lifting weight by an adequate safety factor.

Lifting Procedure

Caution: To prevent damage do not use a forklift to lift the unit.

- [] Install clevis connectors through the four, six or eight lifting plates provided on the unit (Figures 14 thru 17).

WARNING: To prevent injury or death and unit damage, use the lifting method shown in Figures 14 and 17.

- [] Attach lifting chains or cables to clevis connectors. Each cable alone must be strong enough to lift the chiller.
- [] Attach cables to lifting beam. Total lifting weight, lifting weight distribution and required lifting beam dimensions are shown in Figures 14 thru 17 and on the rigging diagram shipped with each unit. Lifting beam crossbars must be positioned so lifting cables do not contact the sides of the unit.

Caution: To prevent unit damage, position lifting beam so that cables do not contact the unit.

Figure 14
Rigging and Lifting Weights for
RTAA Packaged Unit

130-200 Tons
without Domestic Water Heater

UNIT SIZE	LIFTING WEIGHTS (LBS)				TOTAL WEIGHTS (LBS)	Cg LOCATIONS	
	W1	W2	W3	W4		X	Y
130	3105	2727	2473	2175	10480	104.3	41.4
140	3105	2726	2485	2182	10500	104.8	41.3
155	3147	2653	2811	2369	10980	107.9	40.5
170	3194	2632	2922	2412	11160	108.7	40.0
185	3080	2645	3160	2715	11600	112.4	40.9
200	3012	2615	3263	2838	11730	114.4	41.1

NOTES:

1. LIFTING CHAINS (CABLES) WILL NOT BE THE SAME LENGTH. ADJUST TO KEEP UNIT LEVEL WHILE LIFTING.
2. DO NOT FORK LIFT UNIT.
3. WEIGHTS ARE TYPICAL FOR UNITS WITH R-22 CHARGE.
4. DEDUCT 740 FROM TOTAL WEIGHT FOR UNITS WITHOUT ARCHITECTURAL LOUVER PANELS.

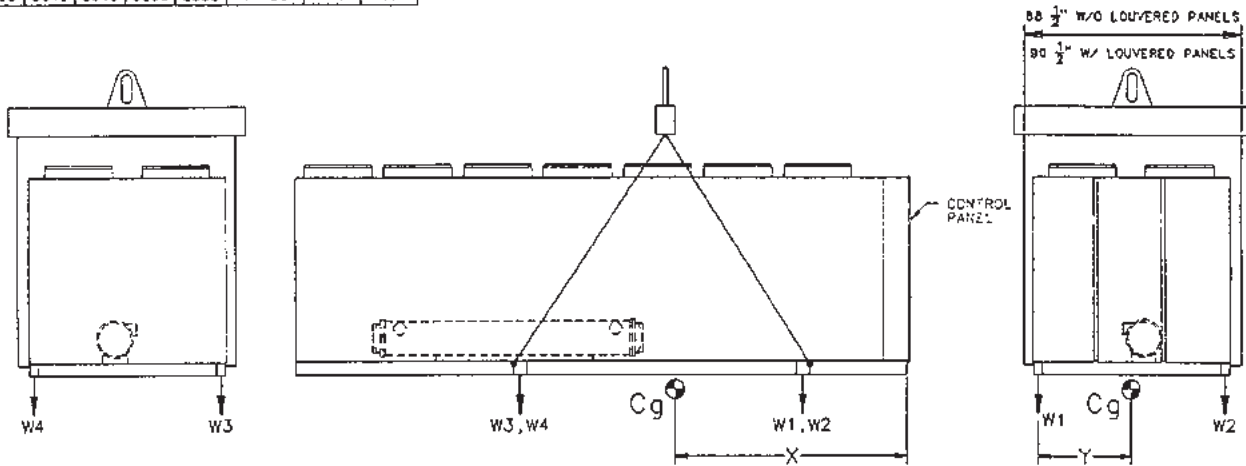

RTAA-SA-2001C

130-200 Tons
with Domestic Water Heater

UNIT SIZE	LIFTING WEIGHTS (LBS)				TOTAL WEIGHTS (LBS)	Cg LOCATIONS	
	W1	W2	W3	W4		X	Y
130	2774	2639	2503	2382	10298	108.0	43.0
140	2774	2637	2521	2397	10329	108.2	42.9
155	2917	2659	2885	2630	11091	111.1	42.0
170	2929	2619	2959	2645	11152	111.8	41.5
185	2872	2651	3205	2958	11687	115.2	42.3
200	2818	2629	3299	3076	11822	116.8	42.5

NOTES:

1. LIFTING CHAINS (CABLES) WILL NOT BE THE SAME LENGTH. ADJUST TO KEEP UNIT LEVEL WHILE LIFTING.
2. DO NOT FORK LIFT UNIT.
3. WEIGHTS ARE TYPICAL FOR UNITS WITH R-22 CHARGE.
4. DEDUCT 740 FROM TOTAL WEIGHT FOR UNITS WITHOUT ARCHITECTURAL LOUVER PANELS.

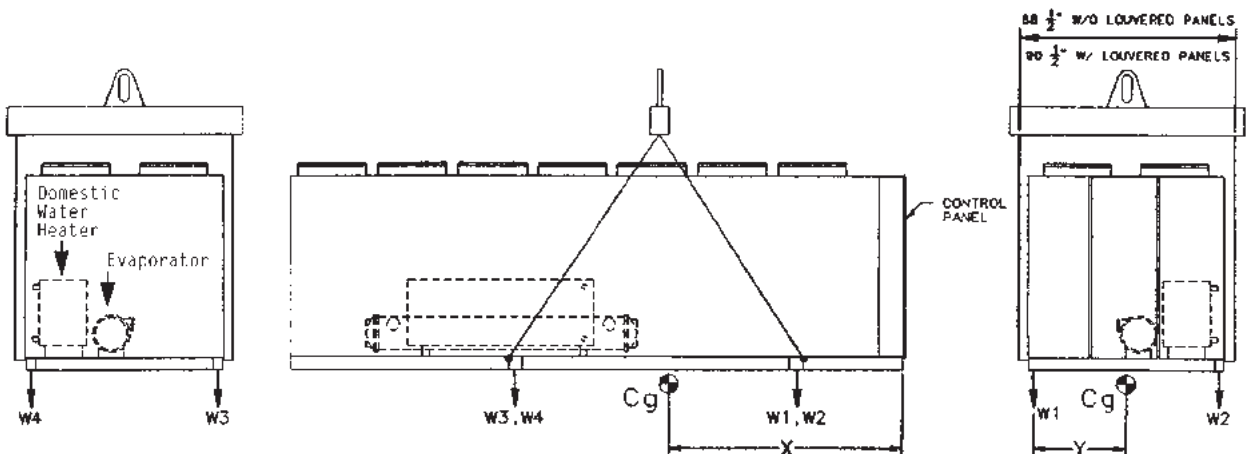

RTAA-SA-2007A

Figure 15
Rigging and Lifting Weights for
RTAA Packaged Unit – 240-300 Tons

UNIT SIZE	LIFTING WEIGHTS (LBS)						TOTAL WEIGHTS (LBS)	Cg LOCATIONS	
	W1	W3	W3	W4	W5	W6		X	Y
246	3111	2906	2908	2718	2705	2532	16860	197.4	42.5
270	3173	2908	3065	2801	2937	2695	17569	200.9	42.1
300	3266	3087	3110	2940	2954	2793	18150	199.6	42.8

NOTES:

1. LIFTING CHAINS (CABLES) WILL NOT BE THE SAME LENGTH. ADJUST TO KEEP UNIT LEVEL WHILE LIFTING.
2. DO NOT FORK LIFT UNIT.
3. WEIGHTS ARE TYPICAL FOR UNITS WITH R-22 CHARGE.
4. DEDUCT 1166 FROM TOTAL WEIGHT FOR UNITS WITHOUT ARCHITECTURAL LOUVER PANELS.

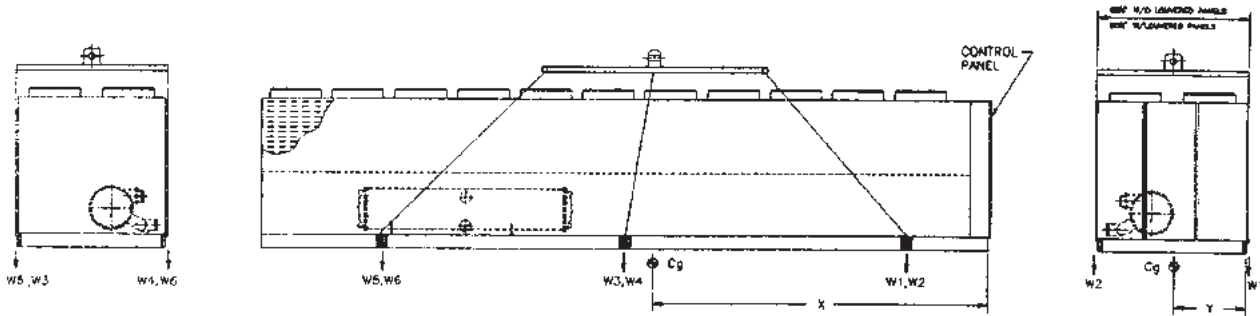

RTAA-SA-2005B

Figure 16
Rigging and Lifting Weights for RTAA
Packaged Unit – 340-400 Tons

UNIT SIZE	LIFTING WEIGHTS (LBS)								TOTAL WEIGHTS (LBS)	Cg LOCATIONS	
	W1	W2	W3	W4	W5	W6	W7	W8		X	Y
349	3162	2871	2921	2745	2738	2573	2494	2346	21949	239.8	42.6
370	3326	3052	3036	2788	2815	2586	2525	2321	22449	236.9	42.1
400	3339	3149	3062	2980	2850	2662	2573	2422	22950	238.0	42.7

NOTES:

1. LIFTING CHAINS (CABLES) WILL NOT BE THE SAME LENGTH. ADJUST TO KEEP UNIT LEVEL WHILE LIFTING.
2. DO NOT FORK LIFT UNIT.
3. WEIGHTS ARE TYPICAL FOR UNITS WITH R-22 CHARGE.
4. DEDUCT 1480 FROM TOTAL WEIGHT FOR UNITS WITHOUT ARCHITECTURAL LOUVERED PANELS.

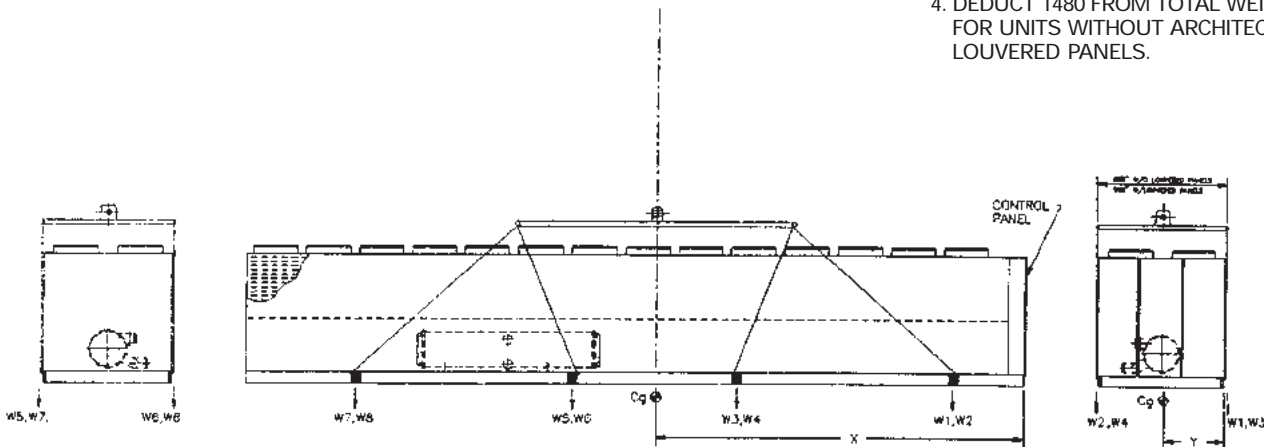

RTAA-SA-2006B

Figure 17
Rigging and Lifting Weights for
RTAA Outdoor Unit with
Remote Evaporator Option

UNIT SIZE	LIFTING WEIGHTS (LBS)				TOTAL WEIGHTS (LBS)	Cg LOCATIONS	
	W1	W2	W3	W4		X	Y
130	2421	2683	1318	1460	7880	92.7	41.9
140	2421	2683	1318	1460	7880	92.7	41.9
155	2443	2834	1448	1680	8405	95.3	40.9
170	2400	2853	1440	1712	8405	95.6	40.4
185	2450	2780	1707	1938	8873	100.0	41.4
200	2438	2720	1794	2002	8952	102.0	41.8

NOTES:

1. LIFTING CHAINS (CABLES) WILL NOT BE THE SAME LENGTH. ADJUST TO KEEP UNIT LEVEL WHILE LIFTING.
2. DO NOT FORK LIFT UNIT.
3. WEIGHTS ARE TYPICAL FOR UNITS WITH R-22 CHARGE.
4. DEDUCT 740 FROM TOTAL WEIGHT FOR UNITS WITHOUT ARCHITECTURAL LOUVER PANELS.

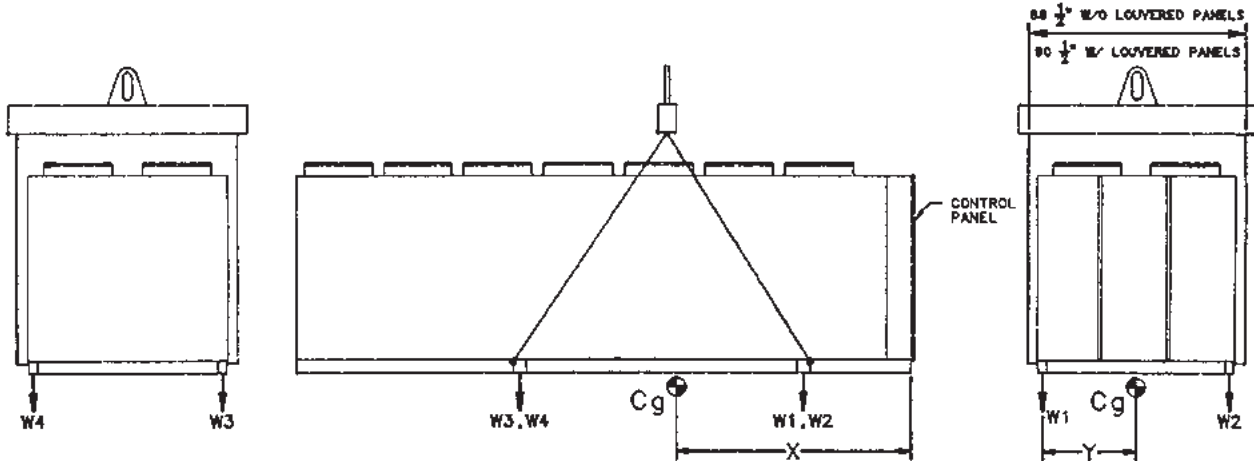

Unit Isolation and Leveling

For additional reduction of sound and vibration, use one of the two mounting methods outlined below:

1. Construct an isolated concrete pad for the unit or provide concrete footings at each of the eight unit mounting points. Mount the unit directly to the concrete pads or footings. Level the unit using the base rail as a reference. The unit must be level within 1/4" over the entire length. Use shims as necessary to level the unit.
2. Install the optional spring isolators at each of the eight/ten unit mounting points. Refer to Figures 18 thru 21 for isolator placement locations and loading information.
 - a. Secure the isolators to the mounting surface, using the mounting slots in the isolator base plate. Do not fully tighten the isolator mounting bolts at this time.
 - b. Positioning pins are located on the top of each isolator, as shown in Figures 18 thru 21. Lower the unit on to the isolators so that the pins register with the unit mounting holes.
 - c. The weight of the unit will force the upper housing of each isolator down. This may cause the upper housing to contact the lower housing. As shown in Figures 18 thru 21, the clearances between upper and lower housings must be 1/4 to 1/2 inch. If the clearance on any isolator is greater than 1/2 inch, it will be necessary to use shims or grout to achieve the required clearance.
 - d. Minor adjustments can be made to the clearance by turning the leveling bolt; clockwise to increase the clearance and counterclockwise to decrease the clearance. All eight isolators must be supporting the entire weight of the unit while these adjustments are being made.

Note: If proper clearances cannot be achieved using the leveling bolts, use shims or grouting under the isolators, as required. Isolators must not straddle small gaps in the shims or grout.

- e. Before tightening the mounting bolts, level the unit using the unit base rail as a reference. The unit must be level within 1/4" over the entire length. Use the leveling bolts and/or additional shims or grout to level the unit.

Evaporator Water Piping

Thoroughly flush all water piping to the unit before making the final piping connections to the unit.

Caution: If using an acidic commercial flushing solution, construct a temporary bypass around the unit to prevent damage to internal components of the evaporator.

Caution: To avoid possible equipment damage, do not use untreated or improperly treated system water.

When completing the NPT-type water connections, apply a suitable pipe sealant, or Teflon tape, to prevent water leakage. To minimize heat gain and to prevent condensation, insulate all piping.

Caution: Avoid overtightening and possible damage of water connections. The lubricating properties of Teflon tape make the possibility of overtightening more likely.

Figure 18
Spring Isolator Placement for
Typical RTAA Packaged Unit – 130 to 200 Tons
without Domestic Water Heater

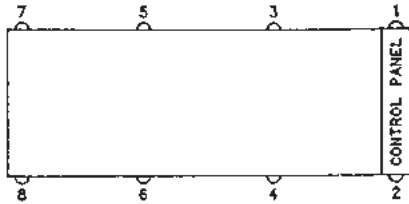

UNIT SIZE	MOUNTING LOCATIONS AND ISOLATOR PART NUMBER							
	LOCATION 1	LOCATION 2	LOCATION 3	LOCATION 4	LOCATION 5	LOCATION 6	LOCATION 7	LOCATION 8
130	CP-2-32	CP-2-31	CP-2-31	CP-2-28	CP-2-28	CP-2-27	CP-1-32	CP-1-31
140	CP-2-32	CP-2-31	CP-2-31	CP-2-28	CP-2-28	CP-2-27	CP-1-32	CP-1-32
155/170	CP-2-32	CP-2-32	CP-2-32	CP-2-31	CP-2-31	CP-2-28	CP-2-27	CP-1-32
185/200	CP-2-32	CP-2-32	CP-2-32	CP-2-31	CP-2-31	CP-2-28	CP-2-28	CP-2-27

UNIT SIZE	WEIGHT ON ISOLATOR AT MOUNTING LOCATION							
	LOCATION 1	LOCATION 2	LOCATION 3	LOCATION 4	LOCATION 5	LOCATION 6	LOCATION 7	LOCATION 8
130	1726	1510	1477	1294	1228	1077	979	859
140	1732	1523	1477	1299	1222	1076	967	854
155	1913	1608	1620	1362	1326	1117	1033	871
170	1942	1604	1651	1365	1360	1125	1067	886
185	1930	1652	1667	1428	1403	1203	1139	978
200	1911	1656	1664	1443	1415	1228	1168	1015

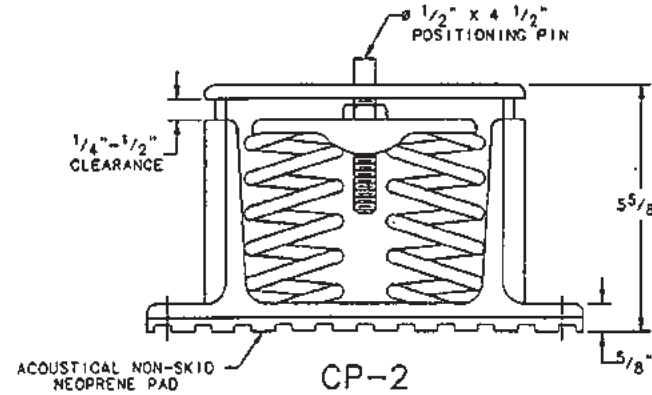
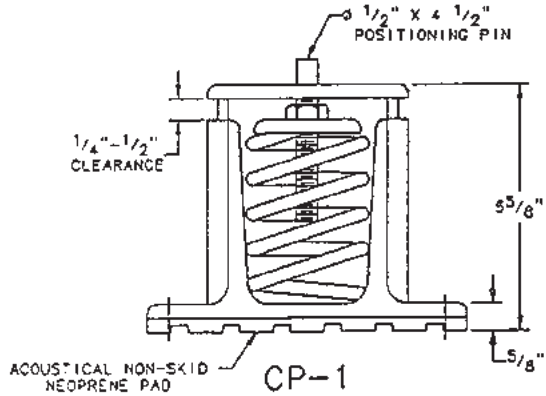
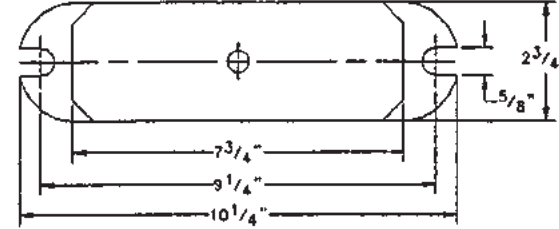
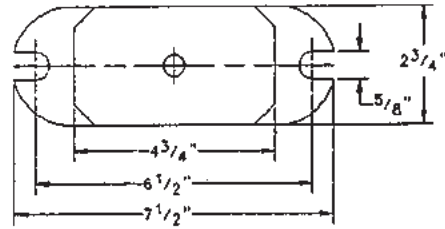

SUFFIX	SPRING COLOR
26	Purple
27	Orange
28	Green
31	Gray
32	White

RTAA-SA-2000B

Figure 19
Spring Isolator Placement for
Typical RTAA Packaged Unit – 240-400 Tons



UNIT	MOUNTING LOCATIONS AND ISOLATOR PART NUMBER									
	LOCATION 1	LOCATION 2	LOCATION 3	LOCATION 4	LOCATION 5	LOCATION 6	LOCATION 7	LOCATION 8	LOCATION 9	LOCATION 10
240	CP-2-32	CP-2-32	CP-2-32	CP-2-32	CP-2-32	CP-2-32	CP-2-32	CP-2-31	CP-2-31	CP-2-31
270	CP-2-32	CP-2-32	CP-2-32	CP-2-32	CP-2-32	CP-2-32	CP-2-32	CP-2-32	CP-2-32	CP-2-31
300	CP-2-32	CP-2-32	CP-2-32	CP-2-32	CP-2-32	CP-2-32	CP-2-32	CP-2-32	CP-2-32	CP-2-31
340	CP-4-31	CP-4-28	CP-4-28	CP-4-28	CP-4-28	CP-4-28	CP-4-27	CP-4-27	CP-4-27	CP-4-28
370	CP-4-31	CP-4-28	CP-4-28	CP-4-28	CP-4-28	CP-4-28	CP-4-27	CP-4-27	CP-4-27	CP-4-27
400	CP-4-31	CP-4-28	CP-4-28	CP-4-28	CP-4-28	CP-4-28	CP-4-28	CP-4-27	CP-4-27	CP-4-27

UNIT	WEIGHT ON ISOLATOR AT MOUNTING LOCATION									
	LOCATION 1	LOCATION 2	LOCATION 3	LOCATION 4	LOCATION 5	LOCATION 6	LOCATION 7	LOCATION 8	LOCATION 9	LOCATION 10
240	1801	1741	1755	1897	1709	1653	1664	1609	1618	1585
270	1854	1752	1824	1723	1793	1694	1763	1686	1733	1637
300	1907	1854	1864	1811	1820	1769	1777	1727	1734	1685
340	2663	2368	2462	2189	2261	2011	2052	1825	1860	1654
370	2672	2440	2475	2260	2276	2080	2073	1893	1884	1720
400	2674	2509	2510	2355	2345	2201	2174	2040	2016	1892

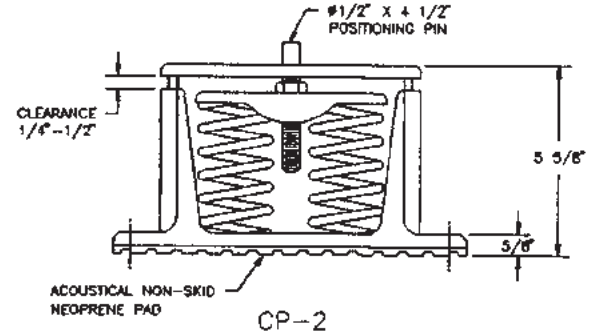
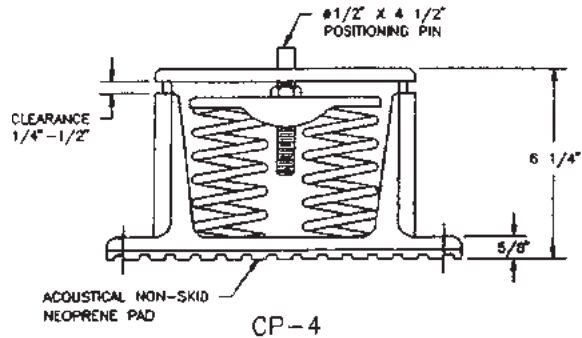
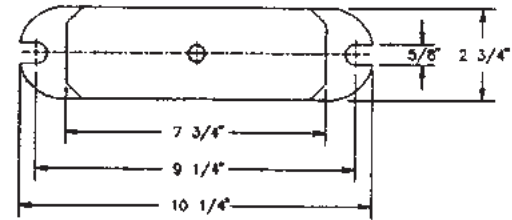
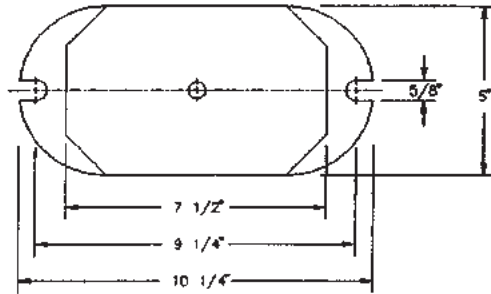

SUFFIX	SPRING COLOR
26	Purple
27	Orange
28	Green
31	Gray
32	White

Figure 20
Spring Isolator Placement for
Typical RTAA Outdoor Unit with
Remote Evaporator Option

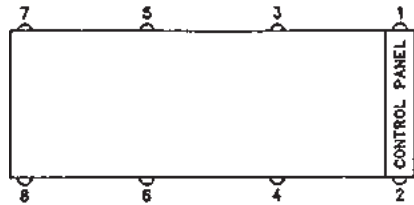

UNIT SIZE	MOUNTING LOCATIONS AND ISOLATOR PART NUMBER							
	LOCATION 1	LOCATION 2	LOCATION 3	LOCATION 4	LOCATION 5	LOCATION 6	LOCATION 7	LOCATION 8
130/140	CP-2-31	CP-2-31	CP-2-28	CP-2-28	CP-1-32	CP-1-32	CP-1-27	CP-1-27
155/170	CP-2-32	CP-2-32	CP-2-31	CP-2-31	CP-1-32	CP-1-32	CP-1-28	CP-1-28
185	CP-2-32	CP-2-32	CP-2-31	CP-2-31	CP-2-28	CP-2-28	CP-1-28	CP-1-28
200	CP-2-32	CP-2-32	CP-2-31	CP-2-31	CP-2-28	CP-2-28	CP-1-31	CP-1-31

UNIT SIZE	WEIGHT ON ISOLATOR AT MOUNTING LOCATION								TOTAL WEIGHTS
	LOCATION 1	LOCATION 2	LOCATION 3	LOCATION 4	LOCATION 5	LOCATION 6	LOCATION 7	LOCATION 8	
130	1594	1438	1222	1102	850	786	477	431	7880
140	1594	1438	1222	1102	850	786	477	431	7880
155	1702	1468	1320	1138	937	808	554	478	8405
170	1717	1444	1333	1121	949	799	568	476	8405
185	1710	1506	1356	1195	1002	883	648	571	8873
200	1689	1512	1350	1209	1011	906	673	602	8952

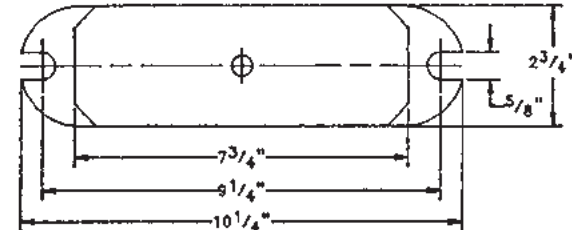
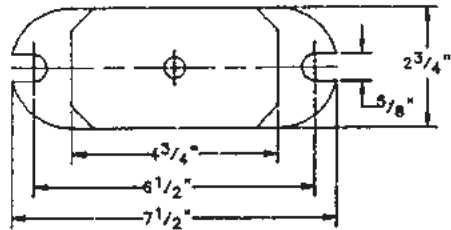

SPRING COLOR	
CP-1-32	WHITE
CP-2-27	ORANGE
CP-2-28	GREEN
CP-2-31	GRAY
CP-2-32	WHITE

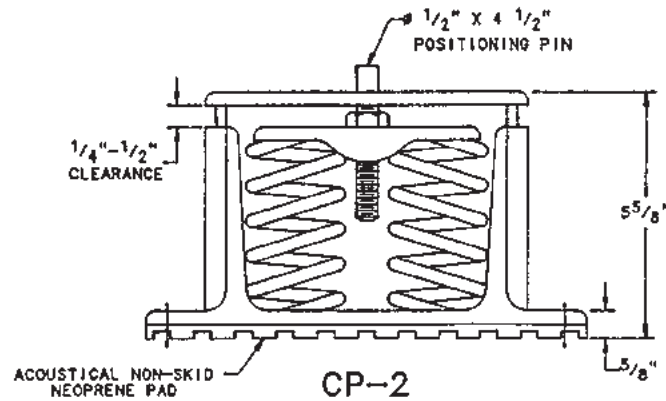
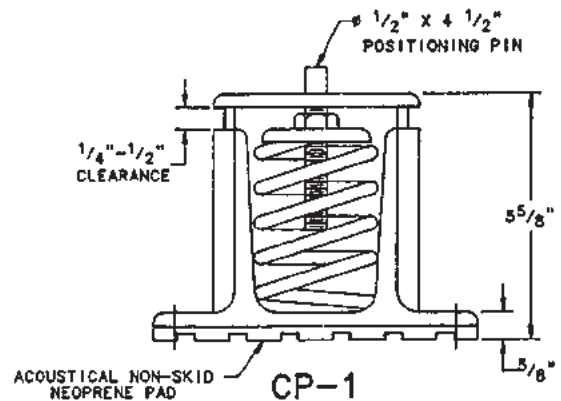

SUFFIX	SPRING COLOR
26	Purple
27	Orange
28	Green
31	Gray
32	White

Figure 21
Spring Isolator Placement for
Typical RTAA Unit with Heat Recovery
Domestic Water Heater

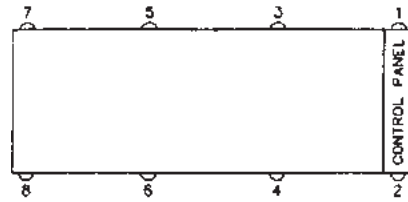

UNIT SIZE	MOUNTING LOCATIONS AND ISOLATOR PART NUMBER							
	LOCATION 1	LOCATION 2	LOCATION 3	LOCATION 4	LOCATION 5	LOCATION 6	LOCATION 7	LOCATION 8
130	CP-2-32	CP-2-31	CP-2-31	CP-2-28	CP-2-28	CP-2-27	CP-1-32	CP-1-31
140	CP-2-32	CP-2-31	CP-2-31	CP-2-28	CP-2-28	CP-2-27	CP-1-32	CP-1-32
155/170	CP-2-32	CP-2-32	CP-2-32	CP-2-31	CP-2-31	CP-2-28	CP-2-27	CP-1-32
185/200	CP-2-32	CP-2-32	CP-2-32	CP-2-31	CP-2-31	CP-2-28	CP-2-28	CP-2-27

UNIT SIZE	WEIGHT ON ISOLATOR AT MOUNTING LOCATION								TOTAL WEIGHTS
	LOCATION 1	LOCATION 2	LOCATION 3	LOCATION 4	LOCATION 5	LOCATION 6	LOCATION 7	LOCATION 8	
130	1695	1607	1423	1349	1151	1091	879	833	10028
140	1696	1608	1425	1350	1153	1093	882	835	10042
155	1839	1662	1579	1427	1319	1192	1058	957	11033
170	1852	1643	1594	1414	1336	1185	1078	956	11058
185	1855	1701	1623	1489	1392	1276	1160	1064	11560
200	1838	1704	1621	1503	1404	1302	1188	1101	11661

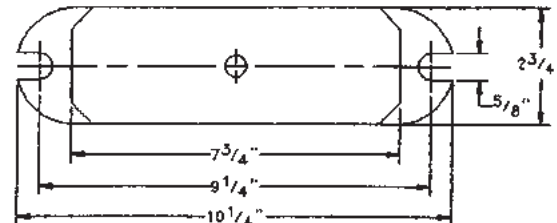
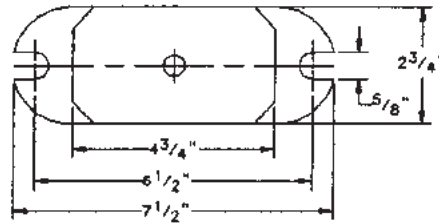

SPRING COLOR	
CP-1-32	WHITE
CP-2-27	ORANGE
CP-2-28	GREEN
CP-2-31	GRAY
CP-2-32	WHITE

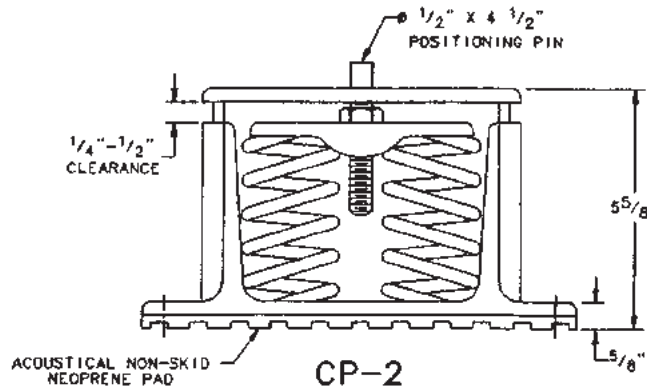
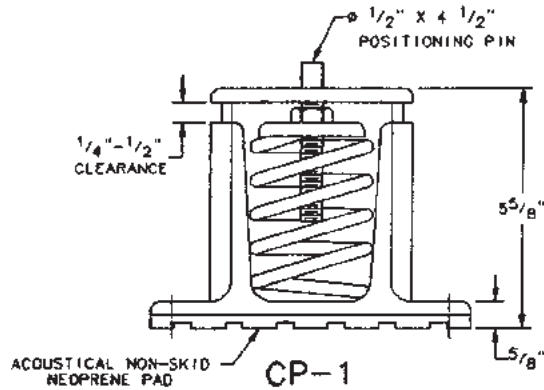

SUFFIX	SPRING COLOR
26	Purple
27	Orange
28	Green
31	Gray
32	White

Evaporator Piping

Figure 22 illustrates typical evaporator piping components. Components and layout will vary slightly, depending on the location of connections and the water source.

Caution: The chilled water connections to the evaporator are to be “victaulic” type connections. Do not attempt to weld these connections, as the heat generated from welding can cause internal damage to the evaporator.

The chilled water connections are on the left side of the unit. If it is necessary for the chilled water piping to enter the unit from the right side, elbows can be used to route the piping 180° over the top of the evaporator, as shown in Figure 22, for RTAA 130-200 units only.

A vent is provided on the top of the evaporator at the return end. Be sure to provide additional vents at high points in the piping to bleed air from the chilled water system. Install necessary pressure gauges to monitor the entering and leaving chilled water pressures.

Caution: To prevent damage to chilled water components, do not allow evaporator pressure (maximum working pressure) to exceed 215 psig.

Provide shutoff valves in lines to the gauges to isolate them from the system when they are not in use. Use rubber vibration eliminators to prevent vibration transmission through the water lines.

If desired, install thermometers in the lines to monitor entering and leaving water temperatures. Install a balancing valve in the leaving water line to control water flow balance. Install shutoff valves on both the entering and leaving water lines so that the evaporator can be isolated for service.

A pipe strainer should be installed in the entering water line to prevent waterborne debris from entering the evaporator.

Figure 22
Suggested Piping for
Typical RTAA Evaporator

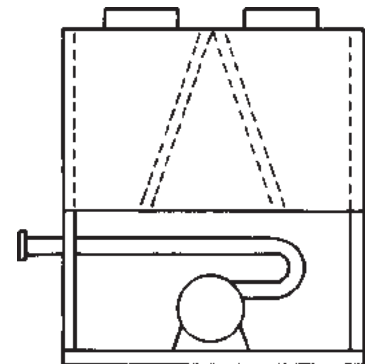
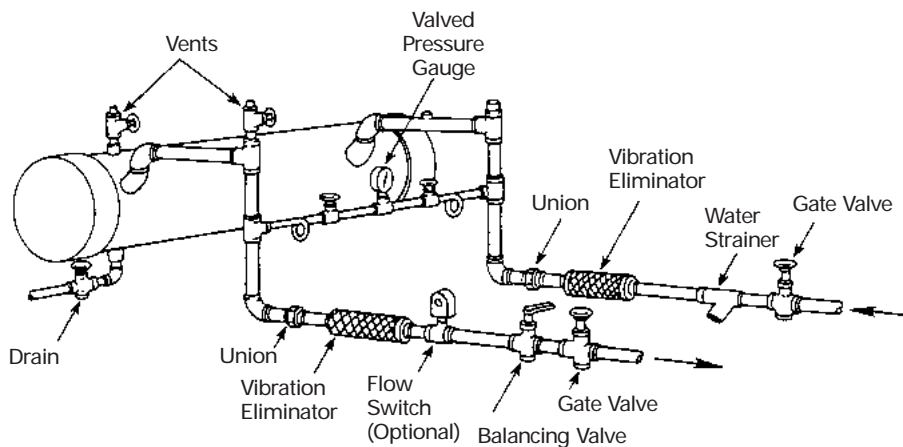

RTAA 130-200
with Opposite-Side Connections
(View from end opposite control panel)

Evaporator Piping Components

“Piping components” include all devices and controls used to provide proper water system operation and unit operating safety. These components and their general locations are given below.

Entering Chilled Water Piping

- [] Air vents (to bleed air from system).
- [] Water pressure gauges with shutoff valves.
- [] Vibration eliminators.
- [] Shutoff (isolation) valves.
Thermometers (if desired).
- [] Clean-out tees.
- [] Pipe strainer.

Caution: To prevent tube damage install strainer in evaporator water inlet piping.

Leaving Chilled Water Piping

- [] Air vents (to bleed air from system).
- [] Water pressure gauges with shutoff valves. Vibration eliminators.
- [] Shutoff (isolation) valves.
- [] Thermometers.
- [] Clean-out tees.
- [] Balancing valve.
- [] Flow Switch (If desired)

Caution: To prevent evaporator damage, do not exceed 215 psig (14.6 bar) evaporator water pressure.

Evaporator Drain

A 3/4" drain connection is located under the outlet end of the evaporator. This may be connected to a suitable drain to permit evaporator drainage during unit servicing. A shutoff valve must be installed on the drain line.

Evaporator Flow Switch

Chilled water flow protection is provided by the UCM without the need for a chilled water flow switch. A flow switch for chilled water is strictly discretionary but if not installed, a signal still must be sent to the chiller to indicate that water flow has been established, e.g. chilled water pump motor starter auxiliary contacts.

If additional chilled water flow protection is desired, use a field-installed flow switch or differential pressure switch with the pump interlock to sense system water flow. Install and wire the flow switch in series with the chilled water pump motor starter auxiliaries (refer to “Electrical Wiring”).

Specific connection and schematic wiring diagrams are shipped with the unit. Some piping and control schemes, particularly those using a single water pump for both chilled and hot water, must be analyzed to determine how and or if a flow sensing device will provide desired operation.

Follow the manufacturer’s recommendations for selection and installation procedures. General guidelines for flow switch installation are outlined below

1. Mount the switch upright, with a minimum of 5 pipe diameters of straight horizontal run on each side. Do not install close to elbows, orifices or valves.

Note: The arrow on the switch must point in the direction of flow.

2. To prevent switch fluttering, remove all air from the water system.

Note: The UCM provides a 6-second time delay after a “loss-of-flow” diagnostic before shutting the unit down. Contact a qualified service representative if nuisance machine shutdowns persist.

3. Adjust the switch to open when water flow falls below nominal. Evaporator data is shown in Figure 23. Refer to Table 1 for minimum flow recommendations. Flow switch contacts are closed on proof of water flow.

4. Install a pipe strainer in the entering evaporator water line to protect components from waterborne debris.

Figure 23
RTAA 130 thru 400
Evaporator Water Pressure Drop

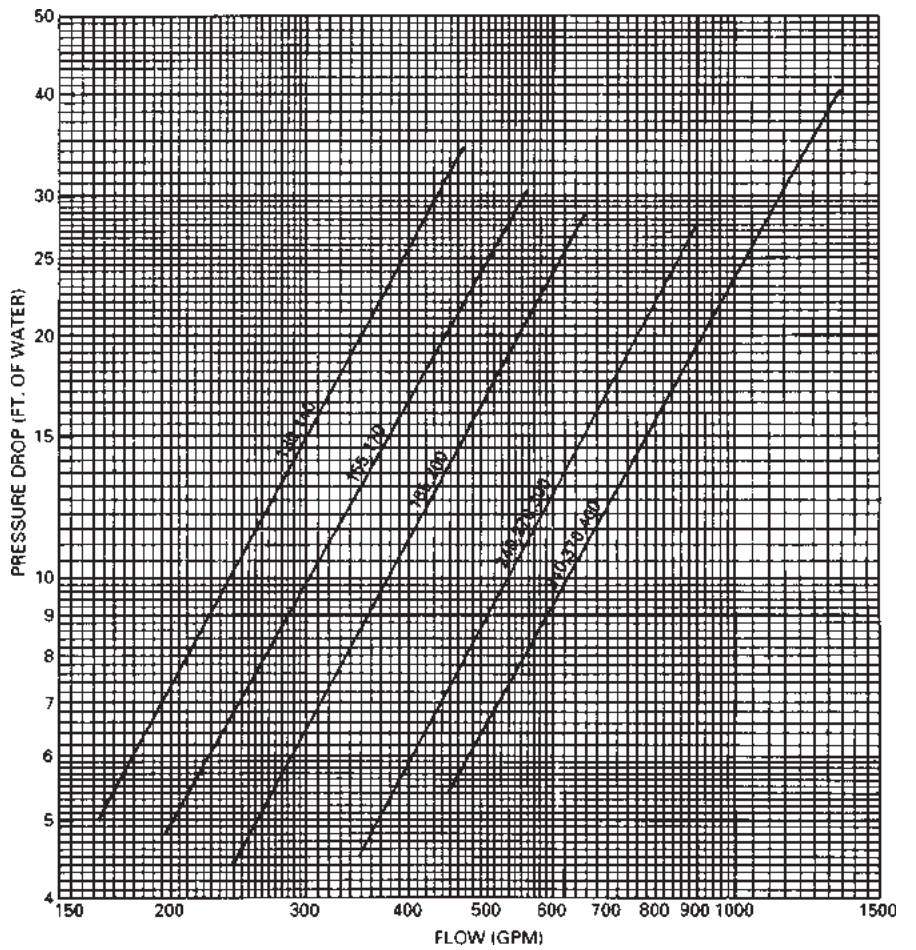

Water Treatment

Using untreated or improperly treated water in these units may result in inefficient operation and possible tube damage. Consult a qualified water treatment specialist to determine whether treatment is needed. The following disclamatory label is provided on each RTAA unit:

Customer Note

The use of improperly treated or untreated water in this equipment may result in scaling, erosion, corrosion, algae or slime. The services of a qualified water treatment specialist should be engaged to determine what treatment, if any, is advisable. The Trane Company warranty specifically excludes liability for corrosion, erosion or deterioration of Trane equipment. Trane assumes no responsibilities for the results of the use of untreated or improperly treated water, or saline or brackish water.

Caution: Do not use untreated or improperly treated water. Equipment damage may occur.

Water Pressure Gauges

Install field-supplied pressure gauges (with manifolds, whenever practical) as shown in Figure 22. Locate pressure gauges or taps in a straight run of pipe; avoid placement near elbows, etc. Be sure to install the gauges at the same elevation on each shell if the shells have opposite-end water connections.

To read manifolded pressure gauges, open one valve and close the other (depending upon the reading desired). This eliminates errors resulting from differently calibrated gauges installed at unmatched elevations.

Water Pressure Relief Valves

Install a water pressure relief valve in the evaporator inlet piping between the evaporator and the inlet shutoff valve, as shown in Figure 22. Water vessels with close-coupled shutoff valves have a high potential for hydrostatic pressure buildup on a water temperature increase. Refer to applicable codes for relief valve installation guidelines.

Caution: To prevent shell damage, install pressure relief valves in the evaporator water system.

Freeze Protection

If the unit will remain operational at subfreezing ambient temperatures, the chilled water system must be protected from freezing, following the steps listed below

1. Heat tape is factory-installed on the packaged unit evaporator and will protect it from freezing in ambient temperatures down to -20 F.
2. Install heat tape on all water piping, pumps, and other components that may be damaged if exposed to freezing temperatures. Heat tape must be designed for low ambient temperature applications. Heat tape selection should be based on the lowest expected ambient temperature.
3. Add a non-freezing, low temperature, corrosion inhibiting, heat transfer fluid to the chilled water system. The solution must be strong enough to provide protection against ice formation at the lowest anticipated ambient temperature. Refer to Table 1 for evaporator water storage capacities.

Note: Use of glycol type antifreeze reduces the cooling capacity of the unit and must be considered in the design of the system specifications.

Domestic Water Heater Piping

Figure 24 illustrates typical domestic water heater piping components. Components and layout will vary slightly, depending on the location of connections and the water source. See unit submittals to insure identification of water inlet and outlet connections.

Be sure to provide additional vents at high points in the piping to bleed air from the water system.

Caution: To prevent damage to components, do not allow domestic water heater pressure (maximum working pressure) to exceed 150 psig.

Use rubber vibration eliminators to prevent vibration transmission through the water lines.

Install a balancing valve in the leaving water line to control water flow balance. Install shutoff valves on both the entering and leaving water lines so that the domestic water heater can be isolated for service.

The vent and drain can be used to temporarily install gauges and determine pressure drop at the heater. Water flow rates, as a function of pressure drop, are charted in Figure 25, or pressure drop can be calculated using the following formula:

Pressure Drop (Ft. H₂O) = 2.31 (Drain psig - Vent psig)

A pipe strainer should be installed in the entering water line to prevent waterborne debris from entering the domestic water heater.

Domestic Water Heater Piping Components

“Piping components” include all devices and controls used to provide proper water system operation and unit operating safety. These components and their general locations are given below.

Entering Water Piping

- Drain
- Vibration eliminators.
- Shutoff (isolation) valves.
- Pipe strainer.

Caution: To prevent tube damage install strainer in the water inlet piping.

Leaving Chilled Water Piping

- Air vents (to bleed air from system)
- Vibration eliminators.
- Shutoff (isolation) valves.
- Balancing valve.

Caution: To prevent damage, do not exceed 215 psig (14.6 bar) domestic water heater water pressure.

Water Pressure Relief Valves

Install a water pressure relief valve in the outlet piping between the domestic water heater and the outlet shutoff valve, as shown in Figure 24. Water vessels with close-coupled shutoff valves have a high potential for hydrostatic pressure buildup on a water temperature increase. Refer to applicable codes for relief valve installation guidelines.

Caution: To prevent shell damage, install pressure relief valves in the evaporator water system.

Freeze Protection

If water in the domestic water heater will be subjected to subfreezing ambient temperatures, the water system must be protected from freezing, following the steps listed below:

1. Heat tape is factory-installed on the domestic water heater and will protect it from freezing in ambient temperatures down to -20 F. Insure that electrical power is provided for the heat tape.
2. Install heat tape on all water piping, pumps, and other components that may be damaged if exposed to freezing temperatures. Heat tape must be designed for low ambient temperature applications. Heat tape selection should be based on the lowest expected ambient temperature.

Figure 24
 Typical Domestic Water
 Heater Piping

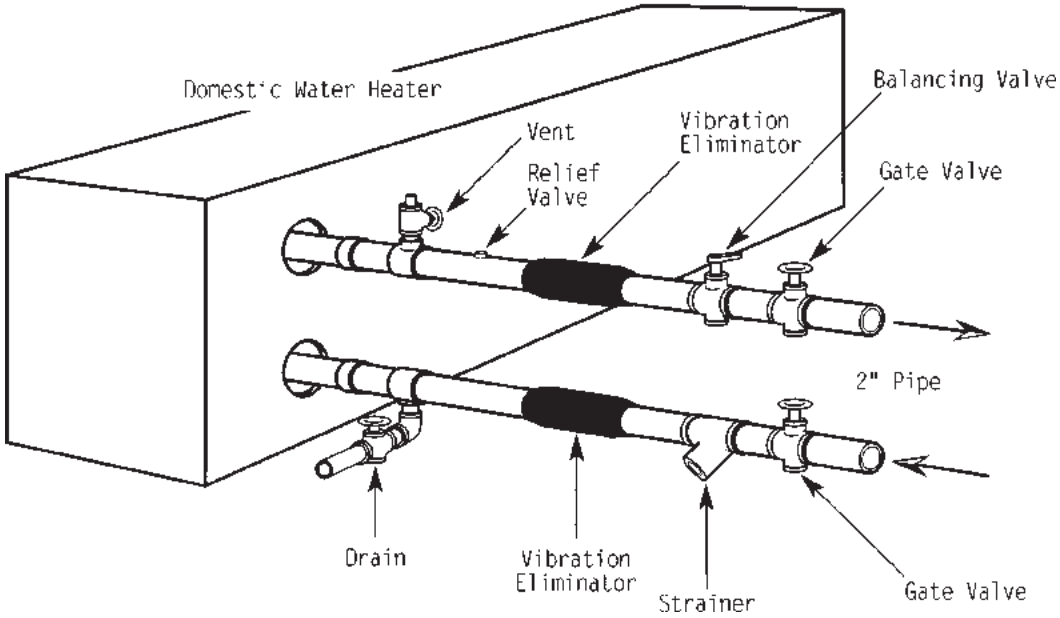
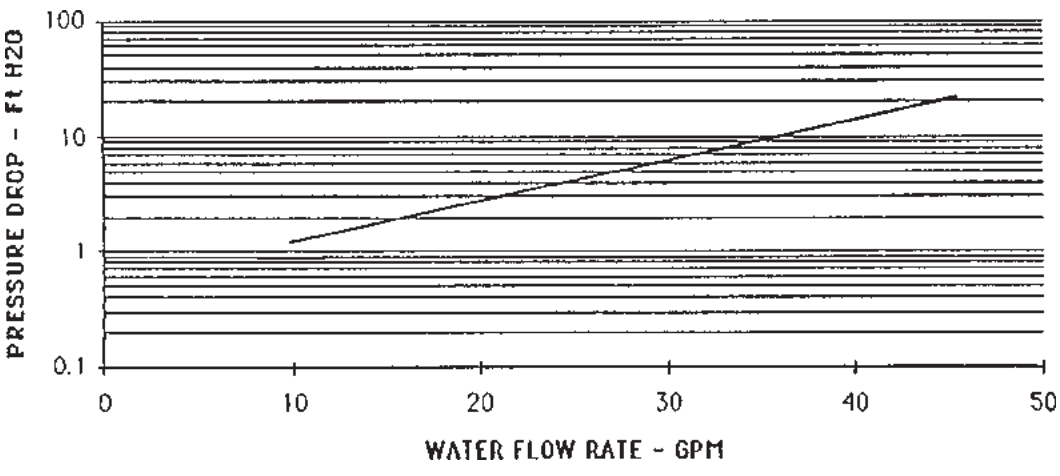

Figure 25
 Typical Domestic Water
 Heater Piping



Installation - Mechanical

Remote Evaporator Interconnecting Refrigerant Piping.

General

The RTAA outdoor unit with the Remote Evaporator option is shipped as two pieces: the outdoor unit (condensing) and the evaporator. The outdoor unit includes a suction accumulator line on each circuit and has the field connections for the refrigerant at the end opposite the control panel.

The evaporator is shipped complete with factory-mounted refrigeration specialties (electronic expansion valves, sight-glasses and removable core filter-driers). All evaporator refrigerant line connections are at one end of the evaporator. The installing contractor need only provide and install the refrigerant piping between the evaporator and the outdoor unit.

System Configuration

The system may be configured in either of the two primary arrangements as shown in Figures 26 and 27. The configuration and its associated elevation, along with the total distance between the remote evaporator and the compressor/condenser section, play a critical role in determining suction and liquid line sizes. This will also affect field refrigerant and oil charges. Consequently, there are physical limits which must not be violated if the system is to operate as designed. Please note the following restrictions:

Figure 26
Remote Evaporator Installation –
No Elevation Difference

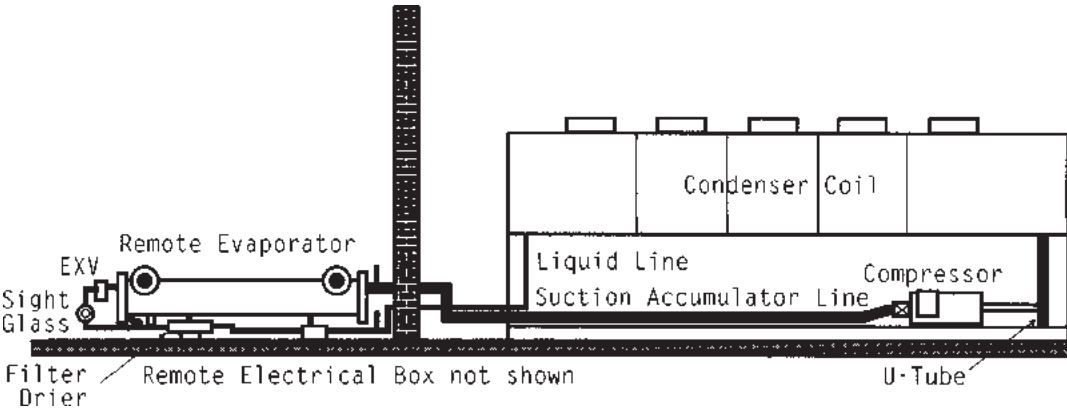

A. The line sizes established in this installation manual are to be used only for 40-50 F leaving water temperature and full-load ice-making applications.

B. The evaporator can be mounted only on the SAME PLANE OR LOWER PLANE than the outdoor unit. Figure 28 illustrates what not to do. The elevation difference is to not exceed 100 feet.

C. Piping between evaporator and outdoor unit is to not exceed 200 (linear) feet or an equivalent length (includes equivalent length pressure drop of fittings) of 300 feet.

D. The suction line must never cross or be above a plane that is 1'8" above the bottom of the outdoor unit. Figure 29 illustrates what not to do.

Figure 27
Remote Evaporator Installation –
Condenser and Compressor
above Evaporator

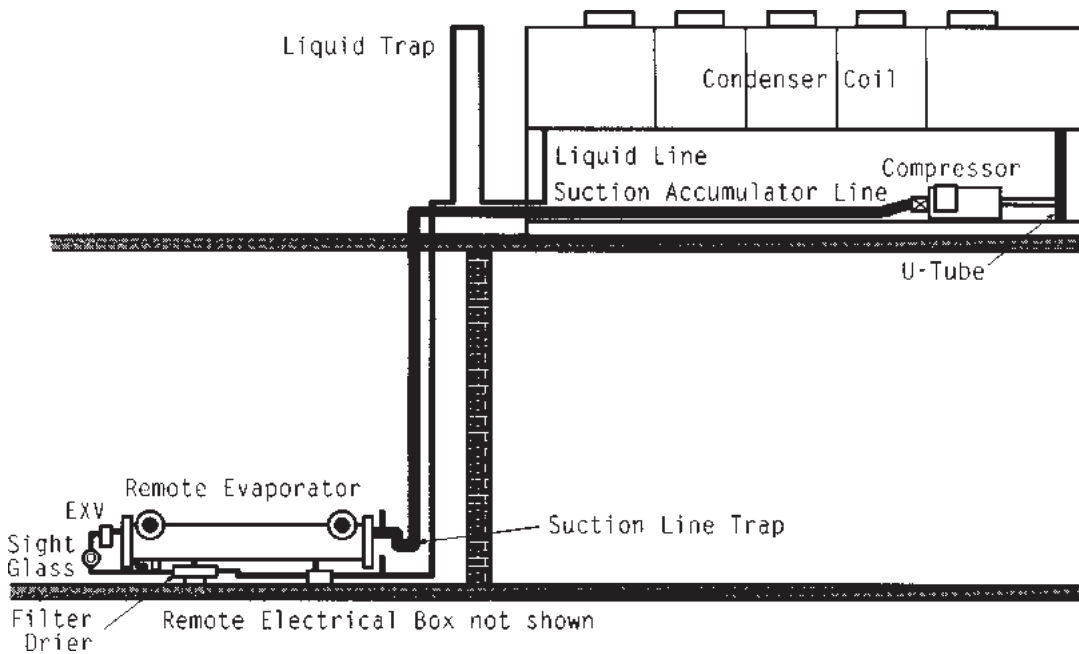

E. Horizontal portions of the suction lines must be downward sloping to the compressors. Suction lines must be insulated.

F. Install an inverted trap in the liquid line when the evaporator is on a lower plane than the outdoor unit. The apex of the trap should be at a height above the top of the condenser coils. See Figure 27.

G. Install a suction line trap at the evaporator when the evaporator is on a lower plane than the outdoor unit. See Figure 27.

H. The evaporator MUST be matched with its respective outdoor unit. The nameplate on the evaporator will have a serial number that is matched to the outdoor unit's serial number. See Figure 7.

Also the circuits on the outdoor unit must match the circuits on the evaporator (I.E. circuit #1 on the outdoor units must be connected with circuit #1 on the evaporator).

Caution: If the circuits are crossed, serious equipment damage may occur.

See Figure 30 for circuit number identification.

Figure 28
Restricted Installation –
Evaporator is on a Higher Plane
than the Outdoor Unit

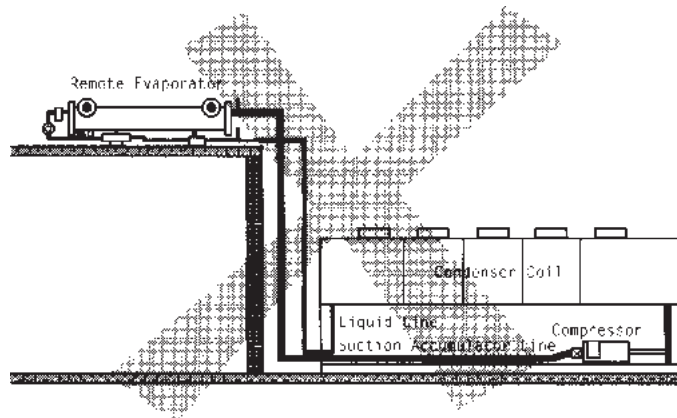

Figure 29 – Restricted Installation -
Suction Line is More Than 1'8"
Above Base of Outdoor Unit

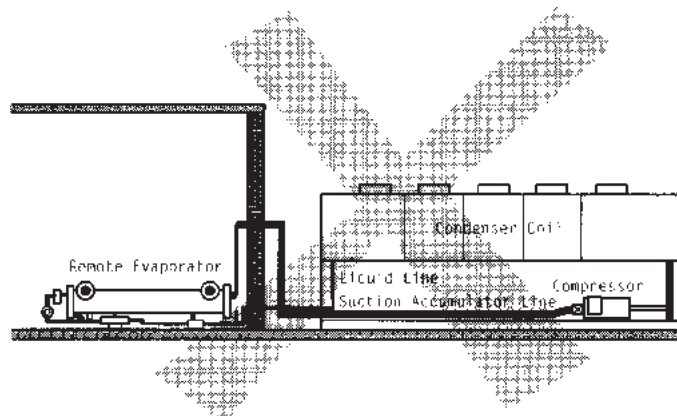
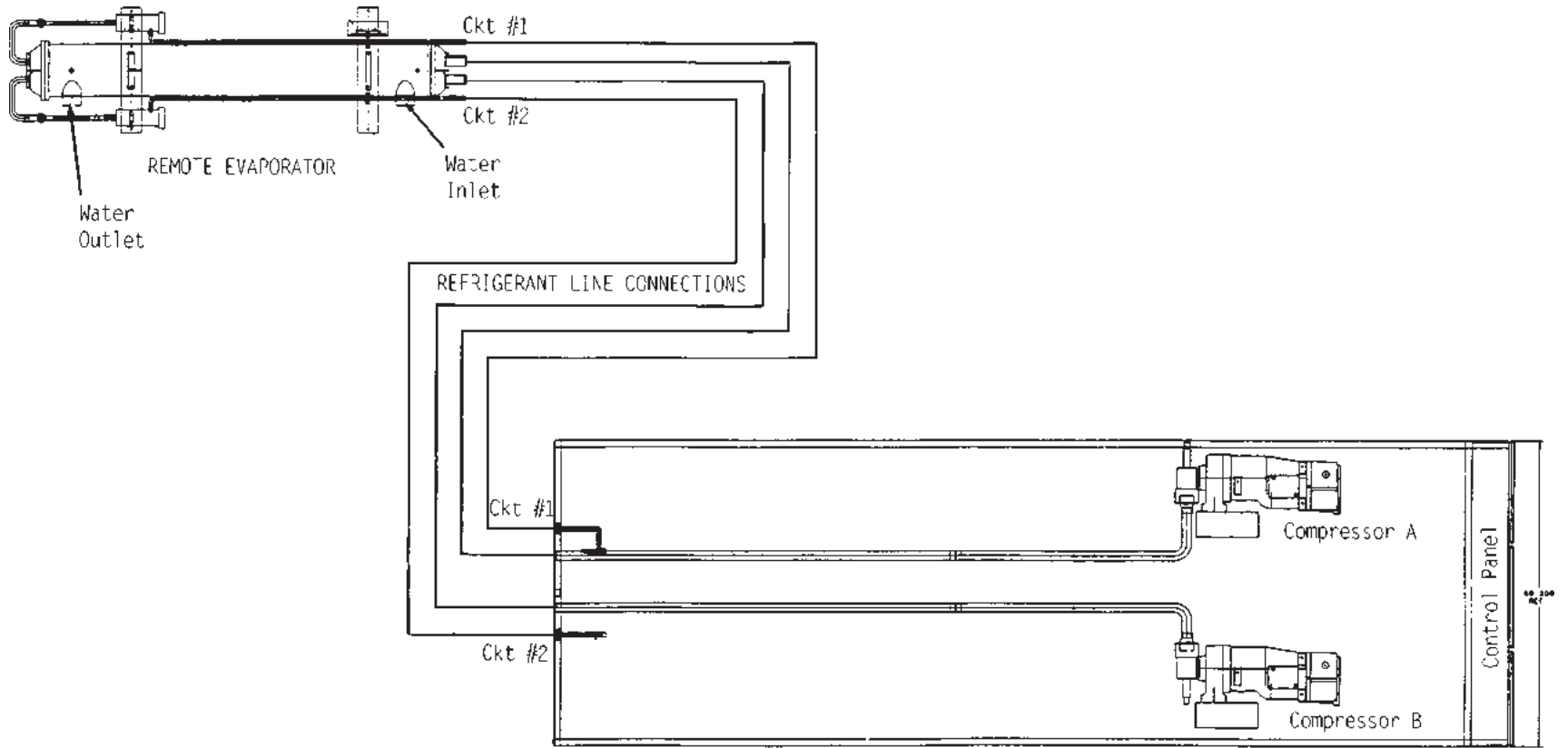

Figure 30
Refrigerant Circuit Identification



Line Sizing

Equivalent Line Length

To determine the appropriate size for field installed liquid and suction lines, it is first necessary to establish the equivalent length of pipe for each line. An initial approximation can be made by assuming that the equivalent length of pipe is 1.5 times the actual length of pipe. These assumed lengths can then be used with the appropriate tables in the Liquid Line Sizing section and the Suction Line Sizing sections which follow.

It is also necessary to know the capacity (tons) of each circuit. Circuit capacities for each RTAA unit are listed in Table 3.

Table 3
RTAA Circuit Capacities

Model	Circuit 1	Circuit 2
130	70	70
140	70	70
155	85	70
170	100	70
185	100	85
200	100	100

The following are examples of how to determine line sizes.

Liquid Line Sizing

This example uses the unit installation shown in Figure 31 and assumes an 85 ton circuit. The actual length of field installed piping is 117 feet (80 + 8 + 8 + 21). Using the factor of 1.5, the equivalent line length is 175 feet.

From Table 4, for horizontal and/or downflow liquid lines, and assuming an 85 ton circuit, 175 feet of equivalent line requires a liquid line with an OD of 1 5/8 in.

There are 6 long-radius elbows in this example. Using Table 5 and the pipe OD of 1 5/8 in., these fittings represent 15.6 feet (6 elbows @ 2.6 feet each). Therefore our new equivalent line length is 132.6 feet (117 + 15.6).

Referring back to Table 4, an 85 ton circuit with 132.6 feet of equivalent pipe length (use the dimension closest to the calculated dimension) can use a pipe O.D. of 1 3/8 in. rather than 1 5/8 in. From Table 5 we see that the 6 elbows of 1 3/8 in. have an equivalent pipe length of 13.2 feet (6 elbows @ 2.2 feet each). This further reduces the equivalent pipe length to 130.2 feet (117 + 13.2), and, as shown in Table 4, still allows the use of 1 3/8 in. O.D. pipe.

Table 4
Liquid Line Size for Horizontal and/or Downflow Lines

Circuit Size: Total Equiv. Length (Ft)	Liquid Line Size (OD")		
	100 Ton	85 Ton	70 Ton
25'	1 1/8	1 1/8	1 1/8
50'	1 3/8	1 1/8	1 1/8
75'	1 3/8	1 3/8	1 3/8
100'	1 3/8	1 3/8	1 3/8
125'	1 3/8	1 3/8	1 3/8
150'	1 5/8	1 3/8	1 3/8
175'	1 5/8	1 5/8	1 5/8
200'	1 5/8	1 5/8	1 5/8
225'	1 5/8	1 5/8	1 5/8
250'	1 5/8	1 5/8	1 5/8
275'	1 5/8	1 5/8	1 5/8
300':	1 5/8	1 5/8	1 5/8

Table 5
Equivalent Lengths of Non-Ferrous valves and Fittings

Line Size Inches OD	Globe Valve	Angle Valve	Short Radius ELL	Long Radius ELL
1 1/8	87	29	2.7	1.9
1 3/8	102	33	3.2	2.2
1 5/8	115	34	3.8	2.6
2 1/8	141	39	5.2	3.4
2 5/8	159	44	6.5	4.2
3 1/8	185	53	8.0	5.1
3 5/8	216	66	10.0	6.3
4 1/8	248	76	12.0	7.3

Reproduced by permission of Air conditioning and Refrigeration Institute.

Figure 31
Remote Evaporator Piping Example

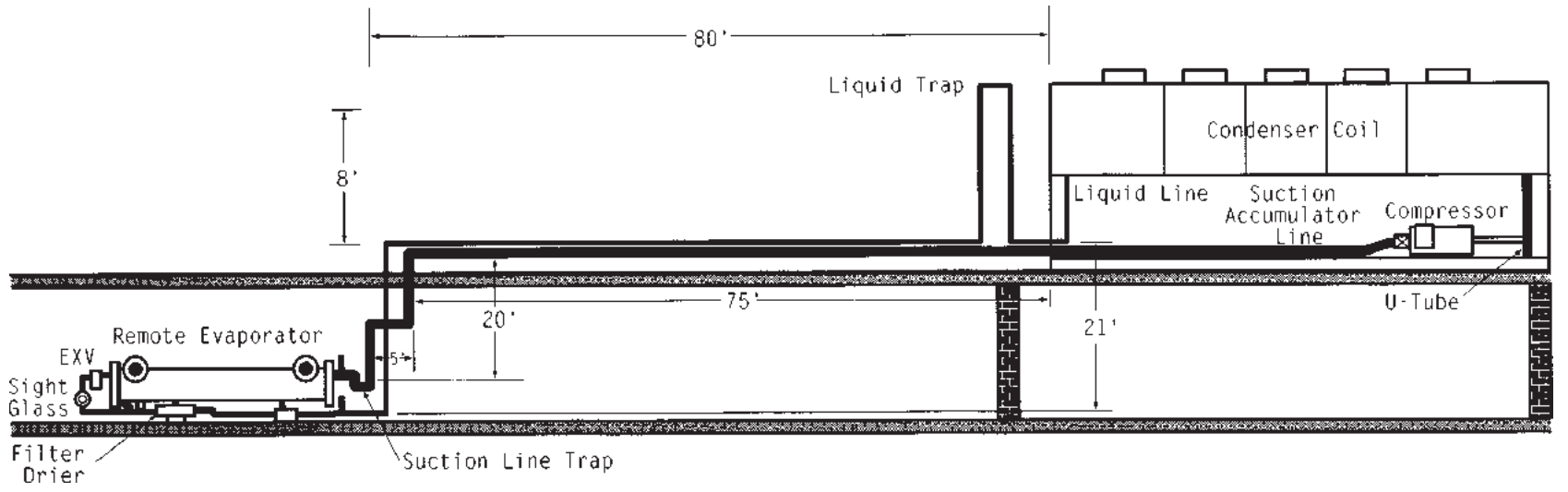

Suction Line Sizing

This example uses the unit installation shown in Figure 31 and assumes a 100 ton circuit. As in the liquid line sizing example, the equivalent pipe length must first be determined. It must also be determined what portion of the pipe is “horizontal and/or downflowing” and what portion is “horizontal and/or upflowing.”

In Figure 31, the actual length of field installed piping is 100 feet (20 + 5 + 75). Using the factor of 1.5, the equivalent line length is 150 feet. The suction line has an elevation of 20 feet and consists of horizontal and vertical (upflowing) sections, which must be sized separately.

The two vertical sections are separated by a small horizontal section. The total distance is 25 feet (20 + 5). The first approximation of equivalent pipe length is 37.5 feet (1.5 times 25). Referring to Table 6 for a horizontal and/or upflow suction line on a 100 ton circuit with 37.5 feet of line, the pipe O.D. should be 3 1/8 in.

There are four long-radius elbows in this section of piping. Using Table 5 and the pipe OD of 3 1/8 in., these fittings represent 20.4 feet (4 elbows @ 5.1 feet each). Therefore our new equivalent line length is 45.4 feet (25 + 20.4). Table 6 indicates that 45.4 equivalent feet still permits the use of 3 1/8 in. O.D. pipe.

In sizing the horizontal and/or downflow portion of the suction line, it is necessary to account for the total equivalent length of the line.

Note: In this example, the horizontal line is pitched downward in the direction of flow

Using Table 7 and 150 feet of equivalent pipe length for a 100 ton circuit, a pipe O.D. of 4 1/8 in. is specified. There are no fittings in the 75 foot horizontal run, so no equivalent fitting lengths need to be determined.

Add the 75 feet of horizontal and/or downflow line to the 45.4 feet of horizontal and/or upflow line, resulting in 120.5 of equivalent pipe length. Table 7 at 125 feet (use the dimension closest to the calculated dimension) indicates the use of 4 1/8 in. O.D. pipe. Therefore, the 4 1/8 in line will have to be reduced for the vertical sections of the line and expanded again for the horizontal sections.

Table 6
Suction Line Size for Horizontal and/or Upflow Lines

Circuit Size: Total Vertical Equiv. Length (Ft)	Suction Line Size (OD")		
	100 Ton	85 Ton	70 Ton
50':	3 1/8	3 1/8	2 1/8
75':	3 1/8	3 1/8	2 1/8
100':	3 1/8	3 1/8	2 1/8

Table 7
Suction Line Size for Horizontal and/or Downflow Lines

Circuit Size: Total Equiv. Length (Ft) (Including vertical section, if any)	Suction Line Size (OD")		
	100 Ton	85 Ton	70 Ton
50':	3 1/8	3 1/8	2 5/8
75':	3 1/8	3 1/8	2 5/8
100':	3 1/8	3 1/8	3 1/8
125':	4 1/8	3 1/8	3 1/8
150':	4 1/8	3 1/8	3 1/8
175':	4 1/8	4 1/8	3 1/8
200':	4 1/8	4 1/8	3 1/8
225':	4 1/8	4 1/8	3 1/8
250':	4 1/8	4 1/8	3 1/8
275':	4 1/8	4 1/8	3 1/8
300':	4 1/8	4 1/8	3 1/8

Piping Installation Procedures

The outdoor unit and the evaporator are shipped with a 25 psig holding pressure of dry nitrogen. Do not relieve this pressure until field installation of the refrigerant piping is to be accomplished. This will require the removal of the temporary pipe caps.

Note: Use Type L refrigerant-grade copper tubing only.

The refrigerant lines must be isolated to prevent line vibration from being transferred to the building. Do not secure the lines rigidly to the building at any point.

All horizontal suction lines should be pitched downward, in the direction of flow, at a slope of 1/2 in. per 10 feet of run. This allows for larger line size, which will improve unit efficiency.

Do not use a saw to remove end caps, as this may allow copper chips to contaminate the system. Use a tubing cutter or heat to remove the end caps.

When sweating copper joints, flow dry nitrogen through the system. This prevents scale formation and the possible formation of an explosive mixture of R-22 and air. This will also prevent the formation of toxic phosgene gas, which occurs when refrigerant is exposed to open flame.

WARNING: To prevent injury or death, due to explosion and/or inhalation of phosgene gas, purge the system thoroughly while sweating connections. Use a pressure regulator in the line between the unit and the high pressure nitrogen cylinder to avoid over-pressurization and possible explosion.

Refrigerant Sensors

The suction line refrigerant sensors must be installed by the contractor installing the refrigerant piping. The sensors are pre-wired and each is "wire-tied" to its respective liquid line. Fittings and adapters for mounting of the sensors are located in the remote evaporator terminal box. See Figure 32 for mounting instructions.

Figure 32
Customer Interconnect Wiring for
RTAA Outdoor unit with Remote Evaporator -
130 to 200 Tons

NOTES

1. ALL CUSTOMER CONTROL CIRCUIT WIRING MUST HAVE A MINIMUM RATING OF 150 VOLTS.
2. DRILL \varnothing .469 DIA HOLE IN TOP OF CKT #1 & 2 SUCTION LINE. REMOVE ALL CHIPS & DIRT FROM INSIDE TUBING BEFORE BRAZING ADAPTER IN LINES.
3. BRAZE ADAPTERS IN TOP OF SUCTION LINES BEFORE INSTALLATING SENSORS & FITTINGS. USE AWS BRAZING FLUX TYPE 3A OR 3B & BCUP ALLOY.
4. APPLY TEFLON TAPE TO FITTING THREADS BEFORE TIGHTENING.
5. TIGHTEN NUT UNTIL SENSOR WILL NOT TURN BY HAND. THEN TIGHTEN 1-1/4 TURNS. DO NOT OVER TIGHTEN.
6. ORIENT SENSOR WITH SINGLE HOLE SIDE FACING FLOW, INDICATED BY ARROW.

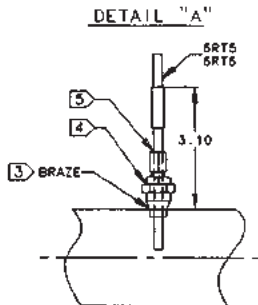
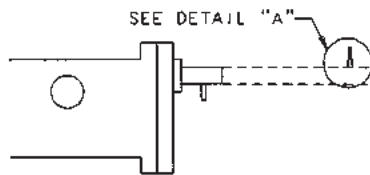
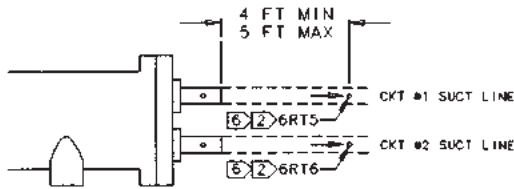

⚠ WARNING

HAZARDOUS VOLTAGE!

DISCONNECT ALL ELECTRIC POWER INCLUDING REMOTE DISCONNECTS BEFORE SERVICING.

FAILURE TO DISCONNECT POWER BEFORE SERVICING CAN CAUSE SEVERE PERSONAL INJURY OR DEATH.

⚠ AVERTISSEMENT

VOLTAGE HASARDEUX!

DECONNECTEZ TOUTES LES SOURCES ELECTRIQUES INCLUANT LES DISJONCTEURS SITUES A DISTANCE AVANT D'EFFECTUER L'ENTRETIEN.

FAUTE DE DECONNECTER LA SOURCE ELECTRIQUE AVANT D'EFFECTUER L'ENTRETIEN PEUT ENTRAINDER DES BLESSURES CORPORELLES SEVERES OU LA MORT.

IMPORTANT

USE COPPER CONDUCTORS ONLY TO PREVENT EQUIPMENT DAMAGE. UNIT TERMINALS ARE NOT DESIGNED TO ACCEPT ANY OTHER WIRING.

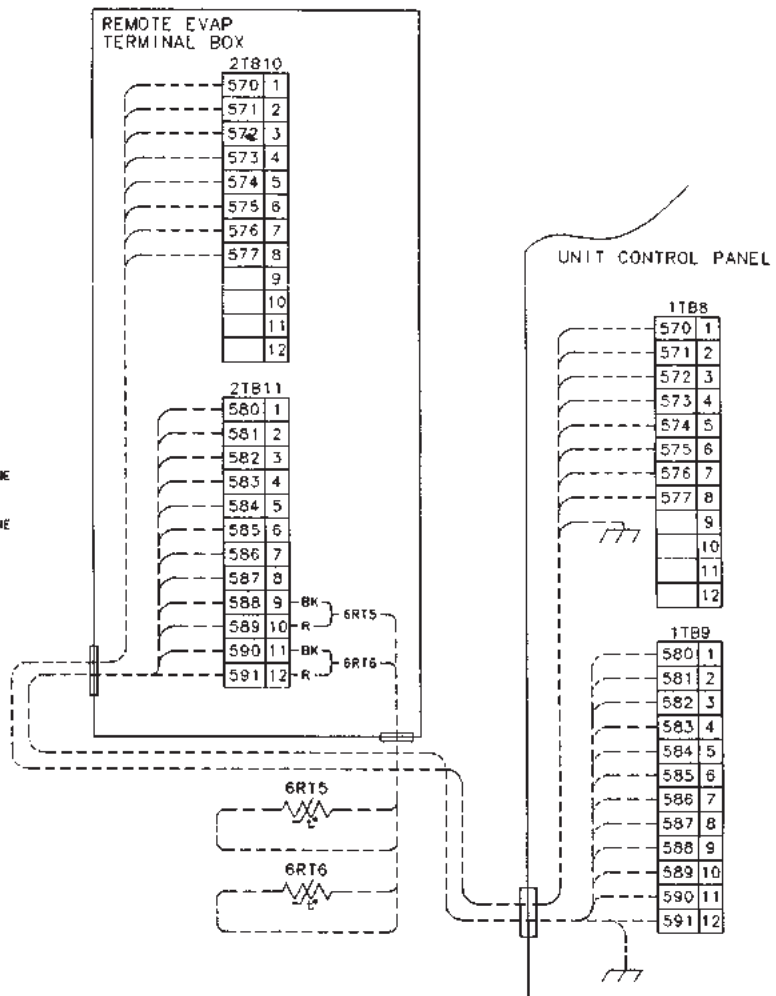

Leak Test and Evacuation

After installation of the refrigerant piping, thoroughly test the system for leaks. Pressure test the system at pressures required by local codes.

Immediately before evacuation, install the liquid line filter cores. These will be shipped with the evaporator.

Note: Do not install these before the circuit is ready for evacuation, as the cores will absorb moisture from the atmosphere.

For field evacuation, use a rotary-type vacuum pump capable of pulling a vacuum of 100 microns or less. Follow the pump manufacturer's instructions for proper use of the pump. The line used to connect the pump to the system should be copper and be the largest diameter that can be practically used. A larger line size with minimum flow resistance can significantly reduce evacuation time.

Use the ports on the compressor suction service valves and the liquid line shutoff valves for access to the system for evacuation. Insure that the compressor suction service valve, the liquid line shutoff valve, the oil line shutoff valve and any field installed valves are open in the proper position before evacuating.

Insulate the entire suction line and the suction accumulator line. Where the line is exposed to the weather, wrap it with weatherproof tape and seal with weatherproof compound.

Refrigerant and Additional Oil Charge

Refrigerant Charge Determination

The approximate amount of refrigerant charge required by the system must be determined by referring to Table 8 and must be verified by running the system and checking the liquid line sightglasses.

Table 8
System Refrigerant Charge

Circuit Size	Lbs. of R-22
70	130
85	165
100	170

To determine the appropriate charge, first refer to Table 8 to establish the required charge required without the field-installed piping. Next, determine the charge required for the field-installed piping by referring to Table 9.

Table 9
Field-installed Piping Charge

Pipe O.D. (inches)	Suction Line	Liquid Line
1 3/8	1.2	63.0
1 5/8	1.7	89.2
2 1/8	2.9	155.2
2 5/8	4.5	239.4
3 1/8	6.4	—
4 1/8	11.3	—

Note: The amounts of refrigerant listed in Table 9 are based on 100 feet of pipe. Actual requirements will be in direct proportion to the actual length of piping.

Note: Table 9 assumes:

Liquid Temperature = 100 F

Suction Temperature = 35 F

Suction Superheat Temperature = 8 F

The approximate amount of refrigerant is therefore the sum of the values determined from Tables 8 and 9.

Example:

Determine the approximate amount of charge required for an RTAA 200 ton unit with a remote evaporator that is located 75 feet away (i.e. the actual length of field installed pipe is 75 feet for each suction line and liquid line). Assume that the suction lines have been previously determined to be 4 1/8 in., O.D. and the liquid lines are 1 3/8 in. O.D.

A 200 ton unit has two 100 ton circuits. From Table 8 above, a 100 ton circuit requires 170 lbs. of R-22. In addition, the 4 1/8 in. O. D. suction line for the 100 ton circuit will require 11.3 lbs. per 100 feet of the 75 feet of line will therefore require 8.5 lbs. (11.3 times 75/100).

Similarly from Table 9, the 1 3/8 in. O.D. liquid line will require 47.3 lbs. of R-22 (63 times 75/100). The total R-22 charge for the 100 ton circuit will be 225.8 lbs. (170 + 8.5 + 47.3). And because the RTAA 200 has two 100 ton circuits, the total system charge will be twice as much, or 461.6 lbs.

Oil Charge Determination

The unit is factory charged with the amount of oil required by the system, without the field-installed piping. The amount of additional oil required is dependent upon the amount of refrigerant that is added to the system for the field-installed piping.

Use the following formula to calculate the amount of oil to be added:

$$\text{Pints of Oil (Trane Oil-15)} = \text{lbs. of refrigerant added for field-installed piping} / 18.375$$

From the example above, in which the weight of the additional refrigerant added for the field-installed piping was 55.8 lbs. (47.3 + 8.5), the amount of oil to be added equals 3 pints (55.8/18.375) per circuit.

Installation – Electrical

General Recommendations

WARNING: The Warning Label shown in Figure 33 is displayed on the equipment and shown on wiring diagrams and schematics. Strict adherence to these warnings must be observed.

All wiring must comply with local codes and the National Electric Code. Typical field wiring diagrams are shown in Figures 34 thru 36. Minimum circuit ampacities and other unit electrical data are on the unit nameplate and are shown in Table 10. See the unit order specifications for actual electrical data. Specific electrical schematics and connection diagrams are shipped with the unit.

Caution: To avoid corrosion and overheating at terminal connections, use copper conductors only.

Do not allow conduit to interfere with other components, structural members or equipment.

Control voltage (115V) wiring in conduit must be separate from conduit carrying low voltage (<30V) wiring.

Caution: To prevent control malfunctions, do not run low voltage wiring (<30V) in conduit with conductors carrying more than 30 volts.

Figure 33
Warning Label

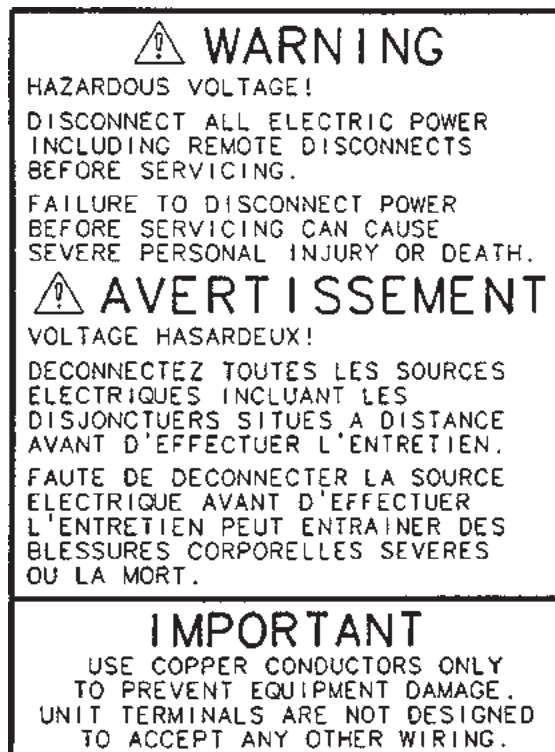

Figure 34
 Typical Field Wiring for
 RTAA Packaged Unit -
 130 to 200 Tons

(Continued on Next Page)

CUSTOMER WIRE SELECTION TABLE				
POWER WIRE SELECTION TO DISCONNECT SWITCH (181)				
UNIT SIZE	UNIT VOLTAGE	DISCONNECT SWITCH SIZE	CONNECTOR WIRE RANGE	
130-140 TON CKT #1&2	200/230V 60HZ	400 AMP	(1) - 3/0 TO 250 MCM	
155-170 TON CKT #2	200/230V 60HZ			
130-140, 155 TON	346V, 380/415V 60HZ, 460 60HZ			
170, 185 TON	380/415V 60HZ, 480V 60HZ			
200 TON	475V 60HZ			
130, 140 TON	380V 60HZ			
180, 146, 166, 170, 185 TON	375V 60HZ	310 AMP	(1) - 250 TO 300 MCM	
165, 170 TON CKT #1	280/230V 60HZ	600 AMP	(2) - 250 TO 300 MCM	
185, 200 TON CKT #1&2	200/230V 60HZ			
170, 185, 200 TON	380/415V 60HZ, 480V 60HZ			
155, 170, 185, 200 TON	380V 60HZ			
POWER WIRE SELECTION TO MAIN TERMINAL BLOCK (1191)				
UNIT SIZE	UNIT VOLTAGE	TERMINAL BLOCK SIZE	CONNECTOR WIRE RANGE	
130-200 TON	200/230 CKT #1 & #2	840 AMP	(2) - #2 TO 600 MCM	
130-200 TON	346V, 380/415V 60HZ, 380V, 460V, 475V 60HZ			
CONTROL WIRE SELECTION FOR 30 VOLT OR LESS CIRCUITS - SEE NOTE 25				
WIRE SIZE	MAXIMUM LENGTH FOR SENSOR LEADS			
14 AWG	6000 FT			
16 AWG	2000 FT			
18 AWG	1000 FT			
FUSE REPLACEMENT SELECTION				
FUSE DESCRIPTION	UNIT SIZE	UNIT VOLTAGE	FUSE TYPE	FUSE SIZE
CONDENSER FAN FUSE (1F1 - 1F12)	ALL	ALL	CLASS RK5 (600V)	35 AMP
CONTROL CIRCUIT FUSE (1F13)	ALL	ALL	BUSS TYPE S	10 AMP
CONTROL POWER TRANSFORMER FUSE (1F14 - 1F17)	ALL	200/230V 60HZ	CLASS RK5 (250V)	5 AMP
		380/415V 60HZ	CLASS RK5 (600V)	5 AMP
		300V 60HZ	CLASS RK5 (600V)	5 AMP
		346V 60HZ	CLASS RK5 (600V)	3.7 AMP
		460V, 475V 60HZ	BUSS BAC-1/4	4 AMP
CHILLER MODULE (1U1) AND OTHER PROTECTION MODULE (1U4 & 1U5)	ALL	ALL	LITTLEFUSE 230-250	0.35 AMP
RVV MODULE FUSE (1U3F1)	ALL	ALL	BUSS GMC-3/10	0.30 AMP
			LITTLEFUSE 230-300	0.20 AMP
			BUSS GMC-2/10	0.30 AMP
			LITTLEFUSE 230-200	0.20 AMP

IMPORTANT
 When there is a command to shutdown the chilled water system, the chilled water pump is required to operate for a minimum of one minute after the External AUTO/STOP gives the shutdown command.

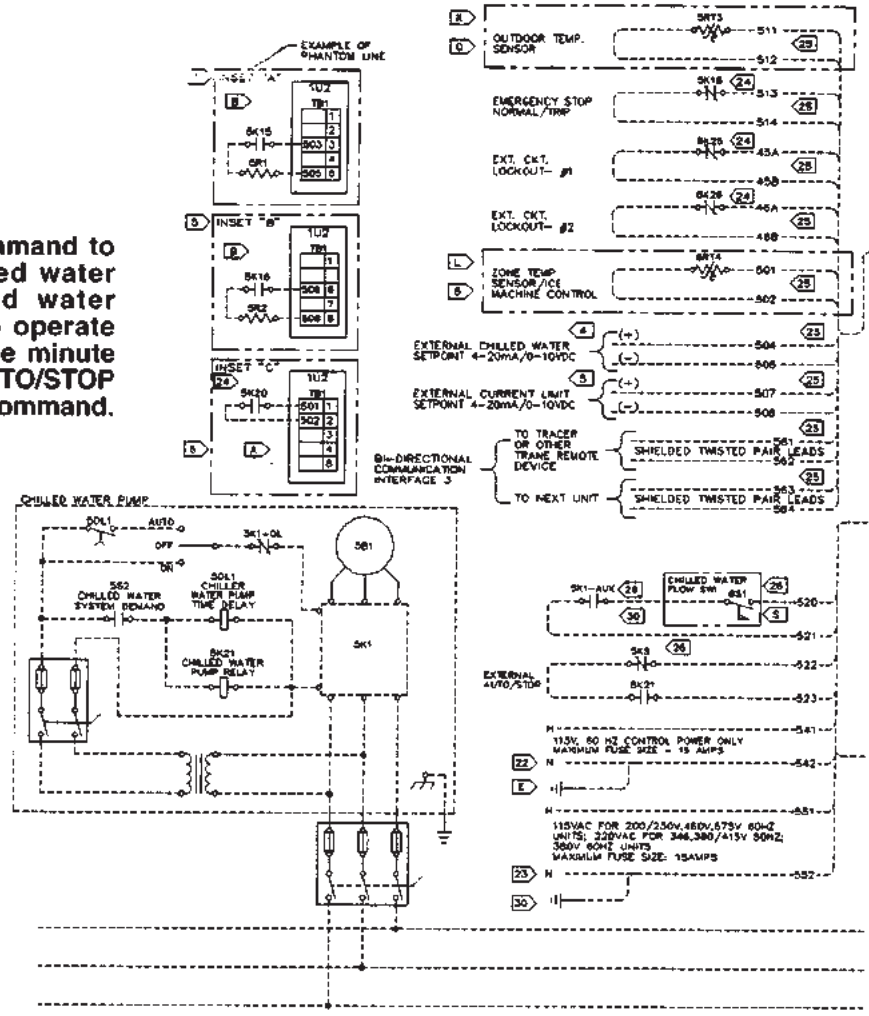

Figure 34 (Continued from Last Page)
 Typical Field Wiring for
 RTAA Packaged Unit –
 130 to 200 Tons

NOTES:

1. DASHED LINES INDICATE RECOMMENDED FIELD WIRING BY OTHERS. PHANTOM LINES INDICATE ALTERNATE CIRCUITRY OR AVAILABLE SALES OPTION. CHECK SALES ORDER TO DETERMINE IF WIRING IS REQUIRED FOR SPECIFIC OPTIONS.
2. ALL THREE PHASE MOTORS SUPPLIED WITH THE UNIT ARE PROTECTED UNDER PRIMARY SINGLE PHASE FAILURE CONDITIONS.
3. CAUTION – DO NOT ENERGIZE UNIT UNTIL CHECK OUT AND START-UP PROCEDURES HAVE BEEN COMPLETED.
4. SEE INSERT "A" FOR RESISTOR CONNECTIONS TO PROGRAM AN EXTERNAL CHILLED WATER SETPOINT WHEN A – 20 mA OR A 2 – 10 VDC SIGNAL IS NOT USED. SEE THE OPERATOR'S MANUAL FOR RESISTOR VALUES.
5. SEE INSERT "B" FOR RESISTOR CONNECTIONS TO PROGRAM AN EXTERNAL CURRENT LIMIT SETPOINT WHEN A – 20 mA OR A 2 – 10 VDC SIGNAL IS NOT USED. SEE THE OPERATOR'S MANUAL FOR RESISTOR VALUES.
6. SEE INSET "C" FOR CONTACTS (IN PLACE OF THE ZONE TEMP. SENSOR) FOR OPTIONAL ICE MACHINE CONTROL – OPTION "A".
7. THE FOLLOWING CAPABILITIES ARE OPTIONAL – THEY ARE IMPLEMENTED AND WIRED AS REQUIRED FOR A SPECIFIC SYSTEM APPLICATION.
 - A ICE-MACHINE CONTROL. (CANNOT BE USED WITH OPT. L)
 - B COMMUNICATIONS INTERFACE
 - D WYE-DELTA CLOSED TRANSITION STARTER
 - E CONTROL POWER TRANSFORMER.
 - H UNIT DISCONNECT, NON-FUSED
 - J CHILLED WATER RESET – RETURN WATER
 - K CHILLED WATER RESET – OUTDOOR AIR
 - L CHILLED WATER RESET – ZONE AIR (CANNOT BE USED WITH OPT. A)
 - O LOW AMBIENT LOCKOUT
 - Q DELUXE CHILLER MODULE (1U1) INCLUDES:
 - REMOTE ALARM/RUNNING/MAX CAPACITY CONTACTS
 - DISPLAY OF K VOLTS
 - DISPLAY OF STARTS AND HOURS BY COMPRESSOR
 - UNDER/OVER VOLTAGE PROTECTION
 - S CHILLED WATER FLOW SWITCH (NOT REQUIRED FOR CHILLER PROTECTION)

⚠ WARNING

HAZARDOUS VOLTAGE!
 DISCONNECT ALL ELECTRIC POWER INCLUDING REMOTE DISCONNECTS BEFORE SERVICING.
 FAILURE TO DISCONNECT POWER BEFORE SERVICING CAN CAUSE SEVERE PERSONAL INJURY OR DEATH.

⚠ AVERTISSEMENT

VOLTAGE HASARDEUX!
 DECONNECTEZ TOUTES LES SOURCES ELECTRIQUES INCLUANT LES DISCONNECTS REMOTE A DISTANCE AVANT D'EFFECTUER L'ENTRETIEN.
 FAUTE DE DECONNECTER LA SOURCE ELECTRIQUE AVANT D'EFFECTUER L'ENTRETIEN PEUT ENTRAÎNER DES BLESSURES CORPORELLES SEVERES OU LA MORT.

IMPORTANT

USE COPPER CONDUCTORS ONLY TO PREVENT EQUIPMENT DAMAGE. UNIT TERMINALS ARE NOT DESIGNED TO ACCEPT ANY OTHER WIRING.

WIRING AND CONTACT REQUIREMENTS:

20. ALL FIELD WIRING MUST BE IN ACCORDANCE WITH THE NATIONAL ELECTRICAL CODE (NEC), STATE, AND LOCAL REQUIREMENTS. OUTSIDE THE UNITED STATES, OTHER COUNTRIES APPLICABLE NATIONAL AND/OR LOCAL REQUIREMENTS SHALL APPLY.
21. FOR CANADIAN INSTALLATION (CSA) ONLY, LOCAL INSPECTION AUTHORITIES MAY REQUIRE SINGLE POWER SOURCE DISCONNECTING MEANS.
22. FOR UNITS WITHOUT THE CONTROL POWER TRANSFORMER (1T1) OPTION, THE CUSTOMER MUST PROVIDE CONTROL POWER OF 115 VAC, 60 HERTZ, SINGLE PHASE, 7.5A ON 130 BRU1 AND 70N UNITS. THE CONTROL POWER TRANSFORMER (1T1) IS STANDARD ON 20 HERTZ UNITS.
23. FOR ALL UNITS, THE HEAT TAPE MUST BE POWERED FROM A SEPARATE CUSTOMER PROVIDED 115 VAC, 420 WATT SOURCE FOR 200/230/420/375 60HZ UNITS, 220 VAC, 420 WATT SOURCE FOR 348/380/418 50HZ UNITS FOR THE OPTIONAL HEAT RECOVERY HEAT TAPE IS 420 WATTS, Ø4664.
24. CUSTOMER SUPPLIED CONTACTS MUST BE COMPATIBLE WITH DRY CIRCUIT 12VDC, 45mA RESISTIVE LOAD. SILVER OR GOLD PLATED CONTACTS ARE RECOMMENDED.
25. 30 VOLT OR LESS CIRCUIT. DO NOT RUN IN CONDUIT WITH HIGHER VOLTAGE CIRCUITS. USE #14-18 AWG. SEE SELECTION TABLE.
26. MINIMUM CONTACT RATING AT 115 VAC: 8.0VA BRUSH, 1.3VA SEALED.
27. FIELD WIRED ELECTRICAL LOADING IS NOT TO EXCEED THE FOLLOWING RATINGS:

TERMINALS	DEVICE	VOLTAGE	SEALED VA	BRUSH VA
1U1-1B4-2.1	1U1K1,NO	115	115	1150a
1U1-1B4-2.3	1U1K1,NC	115	115	1160a
1U1-1B4-2.4	1U1K2,NO	115	115	1150a
1U1-1B4-2.6	1U1K2,NC	115	115	1150a

+ STANDARD PILOT DUTY RATING (35% POWER FACTOR).
28. WHEN CUSTOMER INPUT IS REQUIRED, REMOVE JUMPER AND INSTALL CUSTOMER WIRING.
29. AS SHIPPED 200/230 60HZ AND 380/418 50HZ VOLT UNIT TRANSFORMER 1T1 (OPTIONAL) IS WIRED FOR 200 AND 418 VOLT OPERATION RESPECTIVELY. IF UNIT IS TO BE OPERATED ON A 220 OR 380 VOLT POWER SUPPLY, RECONNECT AS SHOWN IN INSET "D"; IF THE CHILLER MODULE (1U1) UPGRADE (OPTION D) IS USED, CHANGE LOW FACTORY DISPLAY MENU ITEM 43 FROM 200V OR 418V TO 230V OR 380V RESPECTIVELY.
30. REQUIRED WIRING FOR BASIC UNIT OPERATION. ALL OTHER WIRING IS EITHER FOR OPTIONS OR AT THE CUSTOMER'S DISCRETION.
31. 348V,380/415V 50HZ; 380V,480V,575V 60HZ UNITS REQUIRE MAIN POWER CONNECTION ONLY TO 1T1. 200/230V 60HZ UNITS REQUIRE MAIN POWER CONNECTIONS TO BOTH 1T1 (CKT #1) AND 1T2 (CKT #2). POWER WIRING ENTERS LOWER RIGHT HAND SIDE OF CONTROL PANEL.
32. ALL CUSTOMER CONTROL CIRCUIT WIRING MUST HAVE A MINIMUM RATING OF 150 VOLTS.
33. FOR FIELD CONNECTION, CUT, STRIP, AND WIRE NUT EXISTING WIRE LOOP TO FIELD WIRING.
34. THE (3) RELAY OUTPUTS CAN BE PROGRAMMED TO PERFORM ALTERNATE FUNCTIONS. SEE RTAA-IOM-3 FOR DETAILS. FUNCTION #1 IS SHOWN.

Figure 35
 Typical Field Wiring for
 RTAA Packaged Unit –
 240-400 Tons

(Continued on Next Page)

- NOTES:
1. DASHED LINES INDICATE RECOMMENDED FIELD WIRING BY OTHERS. PHANTOM LINES INDICATE ALTERNATE CIRCUITRY OR AVAILABLE SALES OPTION. CHECK SALES ORDER TO DETERMINE IF WIRING IS REQUIRED FOR SPECIFIC OPTIONS.
 2. ALL THREE PHASE MOTORS SUPPLIED WITH THE UNIT ARE PROTECTED UNDER PRIMARY SINGLE PHASE FAILURE CONDITIONS.
 3. CAUTION – DO NOT ENERGIZE UNIT UNTIL CHECK OUT AND START-UP PROCEDURES HAVE BEEN COMPLETED.
 4. SEE INSERT "A" FOR RESISTOR CONNECTIONS TO PROGRAM AN EXTERNAL CHILLED WATER SETPOINT WHEN A = 30 MA OR A 2 = 10 VDC SIGNAL IS NOT USED. SEE THE OPERATORS MANUAL FOR RESISTOR VALUES.
 5. SEE INSERT "B" FOR RESISTOR CONNECTIONS TO PROGRAM AN EXTERNAL CURRENT LIMIT SETPOINT WHEN A = 30 MA OR A 2 = 10 VDC SIGNAL IS NOT USED. SEE THE OPERATORS MANUAL FOR RESISTOR VALUES.
 6. SEE INSERT "C" FOR CONTACTS (IN PLACE OF THE ZONE TEMP. SENSOR) FOR OPTIONAL ICE MACHINE CONTROL – OPTION "I".
 7. THE FOLLOWING CAPABILITIES ARE OPTIONAL – THEY ARE IMPLEMENTED AND WIRED AS REQUIRED FOR A SPECIFIC SYSTEM APPLICATION.
 - A. ICE-MACHINE CONTROL (CANNOT BE USED WITH OPT. L)
 - B. COMMUNICATIONS INTERFACE
 - C. WYE-DELTA CLOSED TRANSITION STARTER
 - E. CONTROL POWER TRANSFORMER
 - H. UNIT DISCONNECT, NON-FUSED
 - J. CHILLED WATER RESET – RETURN WATER
 - K. CHILLED WATER RESET – OUTDOOR AIR
 - L. CHILLED WATER RESET – ZONE AIR (CANNOT BE USED WITH OPT. A)
 - O. LOW AMBIENT LOCKOUT
 - Q. DELUXE CHILLER MODULE (1U1) INCLUDES:
 - REMOTE ALARM/RUNNING/MAX CAPACITY CONTACTS
 - DISPLAY OF % VOLTS
 - DISPLAY OF STARTS AND HOURS BY COMPRESSOR
 - UNDER/OVER VOLTAGE PROTECTION
 - S. CHILLED WATER FLOW SWITCH (NOT REQUIRED FOR CHILLER PROTECTION)

WIRING AND CONTACT REQUIREMENTS:

20. ALL FIELD WIRING MUST BE IN ACCORDANCE WITH THE NATIONAL ELECTRICAL CODE (NEC), STATE, AND LOCAL REQUIREMENTS. OUTSIDE THE UNITED STATES, OTHER COUNTRIES APPLICABLE NATIONAL AND/OR LOCAL REQUIREMENTS SHALL APPLY.
21. FOR CANADIAN INSTALLATION (CSA) ONLY, LOCAL INSPECTION AUTHORITIES MAY REQUIRE SINGLE POWER SOURCE DISCONNECTING MEANS.
22. FOR UNITS WITHOUT THE CONTROL POWER TRANSFORMER (1T1) OPTION, THE CUSTOMER MUST PROVIDE CONTROL POWER OF 115 VAC, 60 HERTZ, SINGLE PHASE, 1000 VA OR 240 THRU 400 TON UNITS, THE CONTROL POWER TRANSFORMER (1T1) IS STANDARD ON 80 HERTZ UNITS.
23. FOR ALL UNITS, THE HEAT TAPE MUST BE POWERED FROM A SEPARATE CUSTOMER PROVIDED 115 VAC, 840 WATT SOURCE FOR 400,275/30 UNITS; 220 VAC, 840 WATT SOURCE FOR 300/20 UNITS.
24. CUSTOMER SUPPLIED CONTACTS MUST BE COMPATIBLE WITH DRY CIRCUIT 120VDC, 45MA RESISTIVE LOAD. SILVER OR GOLD PLATED CONTACTS ARE RECOMMENDED.
25. 30 VOLT OR LESS CIRCUIT, DO NOT RUN IN CONDUIT WITH HIGHER VOLTAGE CIRCUITS. USE #14-18 AWG, SEE SELECTION TABLE.
26. MINIMUM CONTACT RATING AT 115 VAC: 4.5VA INRUSH, 1.5VA SEALED.
27. FIELD WIRE ELECTRICAL LOADS ARE NOT TO EXCEED THE FOLLOWING RATINGS:

TERMINALS	DEVICE	VOLTAGE	SEALED VA	INRUSH VA
1U1-TB4-2.1	1U1K1,ND	115	115	1150+
1U1-TB4-2.3	1U1K1,NC	115	115	1150+
1U1-TB4-3.1	1U1K2,NO	115	115	1150+
1U1-TB4-3.6	1U1K2,NC	115	115	1150+

+ STANDARD PILOT DUTY RATING (USE POWER FACTOR).

28. WHEN CUSTOMER INPUT IS REQUIRED, REMOVE JUMPER AND INSTALL CUSTOMER WIRING.
29. AS SHIPPED, 300/115/30 VOLT UNIT TRANSFORMER (1T1) IS WIRED FOR 415 VOLT OPERATION. IF UNIT IS TO BE OPERATED ON A 380 VOLT POWER SUPPLY, RE-CONNECT AS SHOWN IN INSERT "F". IF THE CHILLER MODULE (1U1) UPGRADE (OPTION Q) IS USED, CHANGE UOM FACTORY DISPLAY MENU ITEM 45 FROM 415V TO 380V.
30. REQUIRED WIRING FOR BASIC UNIT OPERATION. ALL OTHER WIRING IS EITHER FOR OPTIONS OR AT THE CUSTOMERS DISCRETION.
31. ALL CUSTOMER CONTROL CIRCUIT WIRING MUST HAVE A MINIMUM RATING OF 100 VOLTS.
32. FOR FIELD CONNECTION, CUT, STRIP, AND WIRE MUST EXISTING WIRE LOOP TO FIELD WIRING.
33. THE (3) RELAY OUTPUTS CAN BE PROGRAMMED TO PERFORM ALTERNATE FUNCTIONS. SEE RTAA-IOM-3 FOR DETAILS. FUNCTION #1 IS SHOWN.

⚠ WARNING

HAZARDOUS VOLTAGE!
 DISCONNECT ALL ELECTRIC POWER INCLUDING REMOTE DISCONNECTS BEFORE SERVICING.
 FAILURE TO DISCONNECT POWER BEFORE SERVICING CAN CAUSE SEVERE PERSONAL INJURY OR DEATH.

⚠ AVERTISSEMENT

VOLTAGE HASARDEUX!
 DÉCONNECTEZ TOUTES LES SOURCES ÉLECTRIQUES INCLUANT LES DISJONCTEURS SITUÉS À DISTANCE AVANT D'EFFECTUER L'ENTRETIEN.
 FAUTE DE DÉCONNECTER LA SOURCE ÉLECTRIQUE AVANT D'EFFECTUER L'ENTRETIEN PEUT ENTRAÎNER DES BLESSURES CORPORELLES SÉVÈRES OU LA MORT.

IMPORTANT

USE COPPER CONDUCTORS ONLY TO PREVENT EQUIPMENT DAMAGE. UNIT TERMINALS ARE NOT DESIGNED TO ACCEPT ANY OTHER WIRING.

Figure 35 (Continued from Previous Page)
 Typical Field Wiring for
 RTAA Packaged Unit –
 240-400 Tons

(Continued on Next Page)

CUSTOMER WIRE SELECTION TABLE				
POWER WIRE SELECTION TO DISCONNECT SWITCH (151) (1)				
UNIT SIZE	UNIT VOLTAGE	DISC. SW. SIZE (KVA/2)	CONNECTOR WIRE RANGE (KVA/2)	
240 CKT #1/2	360/60,348/90 VOLT	400/400	(1) - 3/0 TO 280 MCM/(2) - 3/0 TO 280 MCM	
	360/219,330 & 480/240 VOLT	400/400	(2) - 3/0 TO 280 MCM/(3) - 3/0 TO 280 MCM	
270 CKT #1/2	360/419,380,480/90 VOLT	400/400	(1) - 3/0 TO 280 MCM/(2) - 3/0 TO 280 MCM	
	360/60,348/90 VOLT	400/400	(3) - 280 TO 800 MCM/(2) - 3/0 TO 280 MCM	
300 CKT #1/2	360/60,348/90 VOLT	400/400	(2) - 3/0 TO 280 MCM/(2) - 3/0 TO 280 MCM	
	348,360/419,380,480,380/90 VOLT	400/400	(2) - 250 TO 500 MCM/(2) - 3/0 TO 280 MCM	
340 CKT #1/2	348,360/419,380,480,380/90 VOLT	400/400	(2) - 3/0 TO 280 MCM/(2) - 3/0 TO 280 MCM	
	378/90 VOLT	400/400	(2) - 3/0 TO 280 MCM/(2) - 3/0 TO 280 MCM	
370 CKT #1/2	348,360/419,380,480,380/90 VOLT	400/400	(2) - 3/0 TO 280 MCM/(2) - 250 TO 500 MCM	
	360/219,348/90 VOLT	400/400	(2) - 250 TO 500 MCM/(2) - 250 TO 500 MCM	
400 CKT #1/2	360/60,348/90 VOLT	400/400	(2) - 3/0 TO 280 MCM/(2) - 3/0 TO 280 MCM	
	348,360/419,380,480/90 VOLT	400/400	(2) - 250 TO 500 MCM/(2) - 250 TO 500 MCM	
	378/90 VOLT	400/400	(2) - 3/0 TO 280 MCM/(2) - 3/0 TO 280 MCM	
POWER WIRE SELECTION TO MAIN TERMINAL BLOCK (178)/2				
UNIT SIZE	UNIT VOLTAGE	TERMINAL BLOCK SIZE	CONNECTOR WIRE RANGE	
270-400	348,360/419,380,480,378,380/90 VOLT CKT #1	840 AMP	(2) - #2 TO 800 MCM	
270-400	348,360/419,380,480,378,380/90 VOLT CKT #2	840 AMP	(2) - #2 TO 800 MCM	
CONTROL WIRE SELECTION FOR 30 VOLT OR LESS CIRCUITS - SEE NOTE 25				
WIRE SIZE	MAXIMUM LENGTH FOR SENSOR LEADS			
14 AWG	5000 FT			
18 AWG	2000 FT			
18 AWG	1000 FT			
FUSE REPLACEMENT SELECTION				
FUSE DESCRIPTION	UNIT SIZE	UNIT VOLTAGE	FUSE TYPE	FUSE SIZE
CONDENSER FAN FUSE (1P1 - 1P12)	ALL	ALL	CLASS RK5(600V)	35 AMP
CONTROL CIRCUIT FUSE (1P10)	ALL	ALL	BUSS TYPE S	15 AMP
POWER CONTROL TRANSFORMER FUSE (1P16-1P17)	ALL	348,360/419,380,480 VOLT	CLASS RK5 (600V)	4.0 AMP
		480/90 VOLT	CLASS RK5 (600V)	3.2 AMP
		378/90 VOLT	CLASS RK5 (600V)	5.0 AMP
CHILLER MODULE(1U)OVERHEAT PROTECTION MODULE(1U4-1U7) FUSE (1U1P1,1U4P1,1U5P1,1U6P1, & 1U7P1)	ALL	ALL	BUSS QMC-1/4 LITTLEFUSE 239,200	0.25 AMP 502mm
EVY MODULE FUSE (1U3F1)	ALL	ALL	BUSS QMC-3/10 LITTLEFUSE 238,300	0.30 AMP 502mm
OPTIONE MODULE FUSE (1U2F2)	ALL	ALL	BUSS QMC-3/10 LITTLEFUSE 239,200	0.30 AMP 502mm

See Notes on Previous Page

IMPORTANT
 When there is a command to shutdown the chilled water pump system, the chilled water pump is required to operate for a minimum of one minute after the External AUTO/STOP gives the shutdown command.

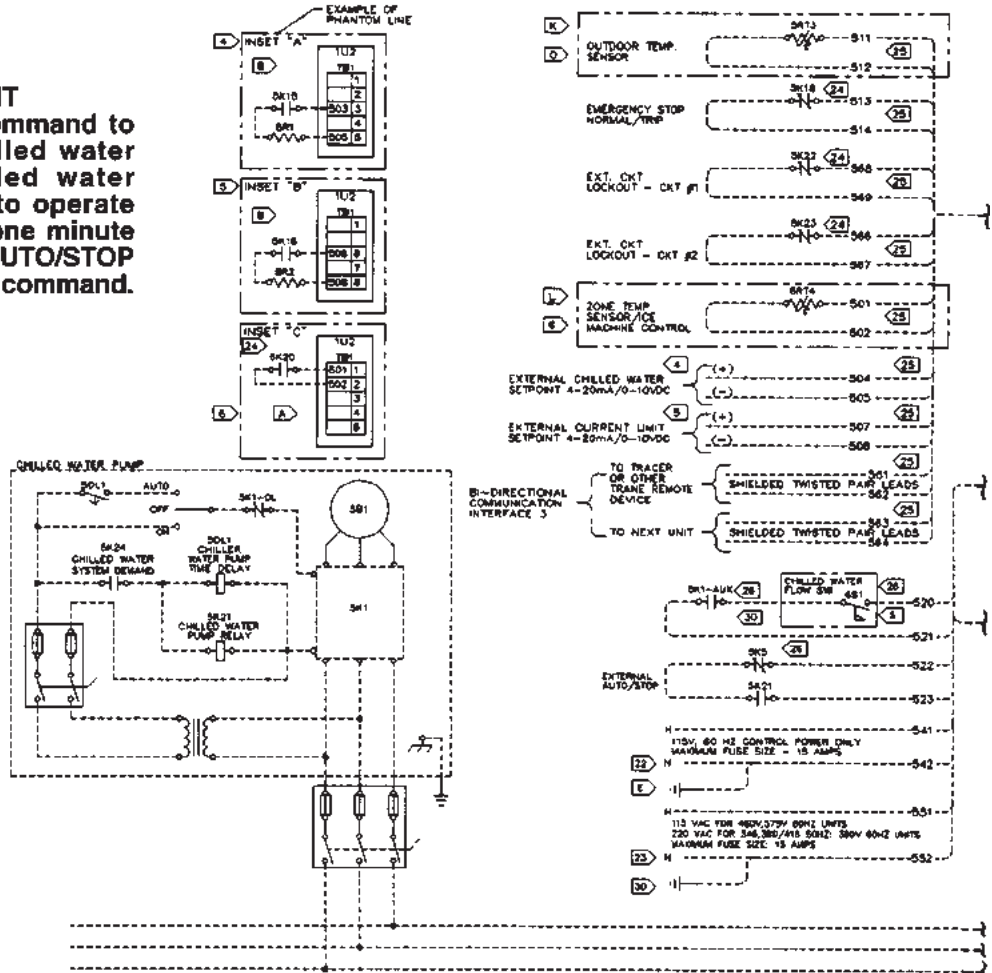

(Continued from Previous Page)

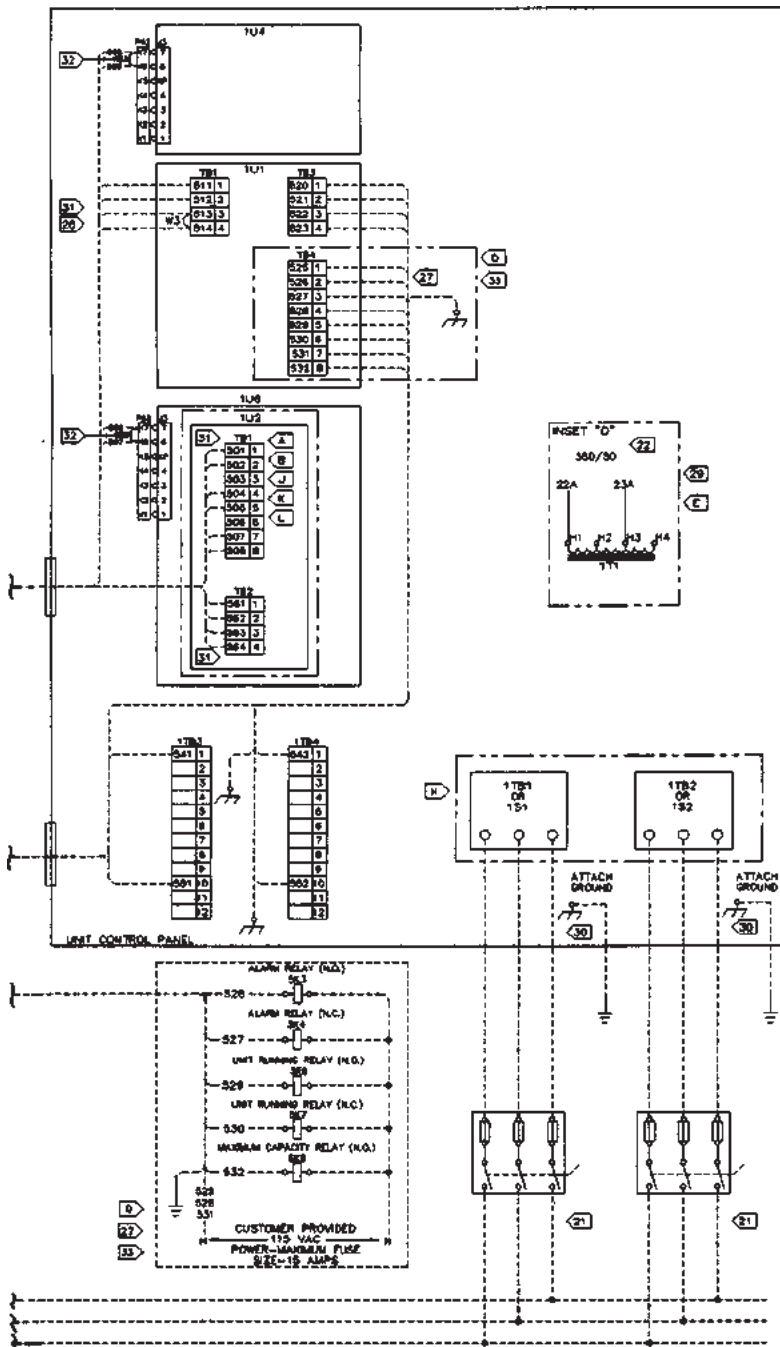

See Notes on Page 61

Figure 36
 Typical Field Wiring for
 RTAA With Remote
 Evaporator Option

(Continued on Next Page)

CUSTOMER WIRE SELECTION TABLE				
POWER WIRE SELECTION TO DISCONNECT SWITCH (191)				
UNIT SIZE	UNIT VOLTAGE	DISCONNECT SWITCH SIZE	CONNECTOR WIRE RANGE	
130,140 TON	200/230V 60HZ	400 AMP	(2) - 3/0 TO 250 MCM	
155,170 TON	200/230V 60HZ			
130,140,155 TON	348V,380/415V 50HZ, 480V 60HZ			
170,185 TON	348/415V 50HZ, 480V 60HZ			
200 TON	375V 60HZ			
130,140 TON	380V 60HZ			
130,140,155,165 TON	375V 60HZ	370 AMP	(1) - 250 TO 350 MCM	
165,170 TON	200/230V 60HZ	400 AMP	(2) - 250 TO 350 MCM	
165,200 TON	200/230V 60HZ			
200 TON	348/415V 50HZ, 480V 60HZ			
170,185,200 TON	348V 50HZ			
155,170,185,200 TON	380V 60HZ			
POWER WIRE SELECTION TO MAIN TERMINAL BLOCK (178)				
UNIT SIZE	UNIT VOLTAGE	TERMINAL BLOCK SIZE	CONNECTOR WIRE RANGE	
130-200 TON	200/230 VLT @ #1 & #2	840 AMP	(2) - #2 TO 600 MCM	
130-200 TON	348V,380/415V 50HZ, 380V,480V,475V 60HZ			
CONTROL WIRE SELECTION FOR 30 VOLT OR LESS CIRCUITS - SEE NOTE 25				
WIRE SIZE	MAXIMUM LENGTH FOR SENSOR LEADS			
14 AWG	3000 FT			
16 AWG	2000 FT			
18 AWG	1000 FT			
FUSE REPLACEMENT SELECTION				
FUSE DESCRIPTION	UNIT SIZE	UNIT VOLTAGE	FUSE TYPE	FUSE SIZE
CONDENSER FAN FUSE (1F1 - 1F12)	ALL	ALL	CLASS RK5 (600V)	35 AMP
CONTROL CIRCUIT FUSE (1F13)	ALL	ALL	BUSF TYPE S	10 AMP
CONTROL POWER TRANSFORMER FUSE (1F15-1F17)	ALL	200/230V 60HZ	CLASS RK5 (250V)	5 AMP
		380/415V 50HZ	CLASS RK5 (600V)	5 AMP
		380V 50HZ	CLASS RK5 (600V)	3.2 AMP
		480V,375V 60HZ	CLASS RK5 (600V)	4 AMP
CHILLER MODULE (1U1) AND OTHER PROTECTION MODULE (1U4 & 1U5)	ALL	ALL	LITTLEFUSE 230,250	600mm
EVAP MODULE FUSE (1U3P1)	ALL	ALL	BUSF GNC-3/0	0.30 AMP
			LITTLEFUSE 230,300	500mm
OPTIONS MODULE (1U3P2)	ALL	ALL	BUSF GNC-2/0	0.20 AMP
			LITTLEFUSE 230,250	500mm

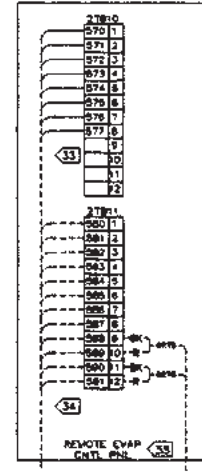

IMPORTANT
 When there is a command to shutdown the chilled water system, the chilled water pump is required to operate for a minimum of one minute after the External AUTO/STOP gives the shutdown command.

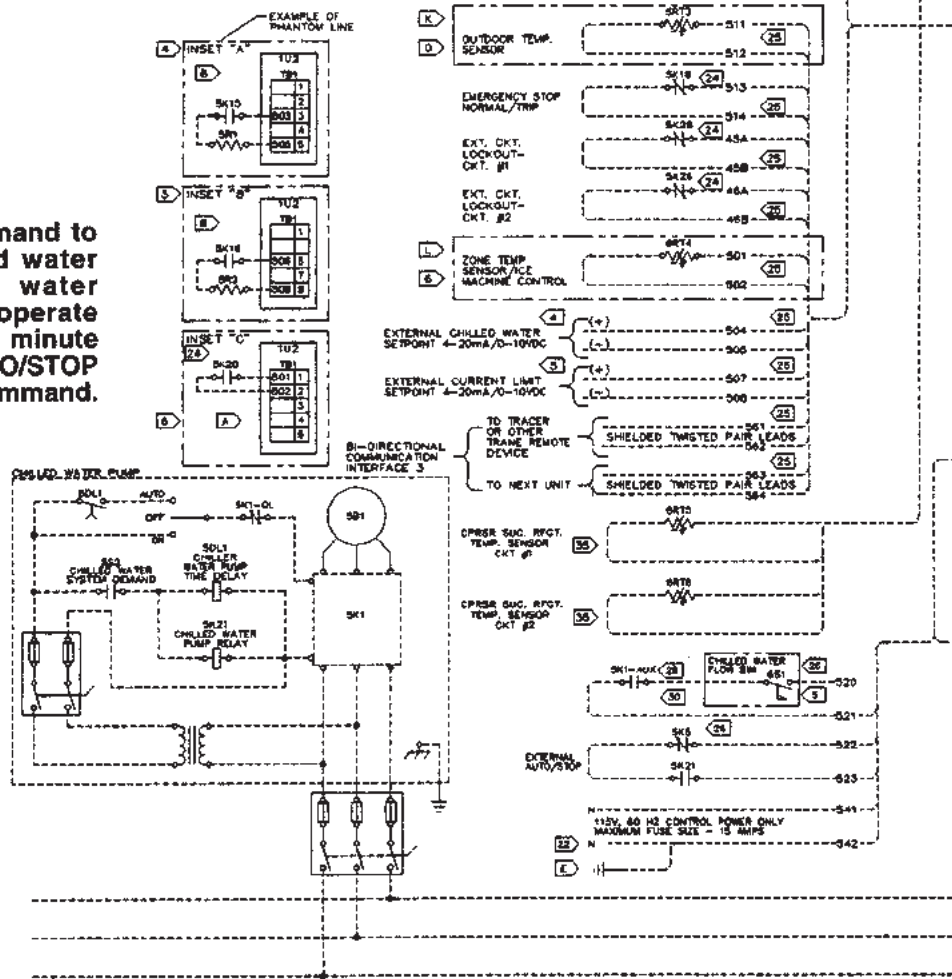

(Continued from Previous Page)

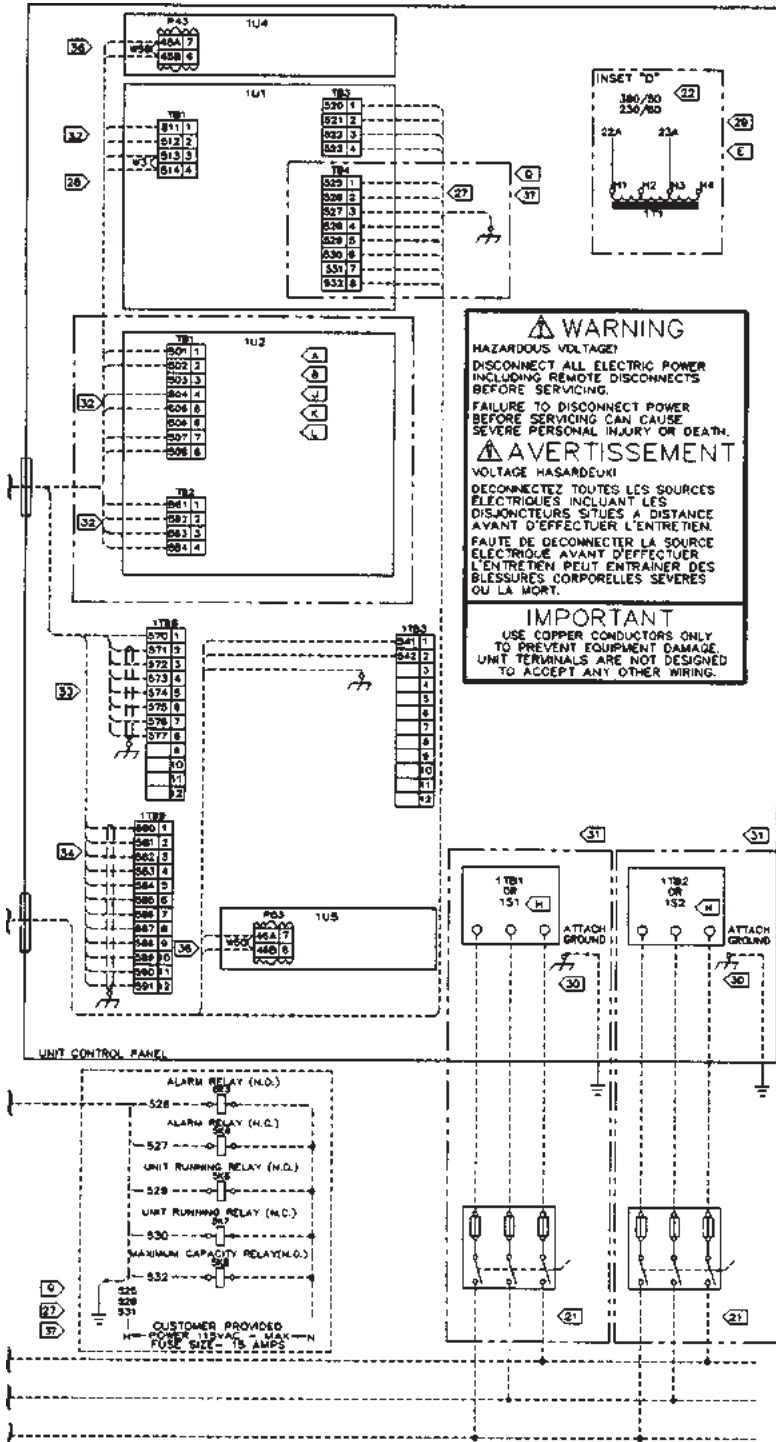

See Notes on Page 61

Figure 36 (Continued from Previous Page)
 Typical Field Wiring for
 RTAA With Remote
 Evaporator Option

- NOTES**
1. DASHED LINES INDICATE RECOMMENDED FIELD WIRING BY OTHERS. PHANTOM LINES INDICATE ALTERNATE DISCREETRY OR AVAILABLE SALES OPTION. CHECK SALES ORDER TO DETERMINE IF WIRING IS REQUIRED FOR SPECIFIC OPTIONS.
 2. ALL THREE PHASE MOTORS SUPPLIED WITH THE UNIT ARE PROTECTED UNDER PRIMARY SINGLE PHASE FAILURE CONDITIONS.
 3. CAUTION - DO NOT ENERGIZE UNIT UNTIL CHECK OUT AND START-UP PROCEDURES HAVE BEEN COMPLETED.
 4. SEE INSET "A" FOR RESISTOR CONNECTIONS TO PROGRAM AN EXTERNAL CHILLED WATER SETPOINT WHEN A = 20 MA OR A 2 = 10 VDC SIGNAL IS NOT USED. SEE THE OPERATORS MANUAL FOR RESISTOR VALUES.
 5. SEE INSET "B" FOR RESISTOR CONNECTIONS TO PROGRAM AN EXTERNAL CURRENT LIMIT SETPOINT WHEN A = 20 MA OR A 2 = 10 VDC SIGNAL IS NOT USED. SEE THE OPERATORS MANUAL FOR RESISTOR VALUES.
 6. SEE INSET "C" FOR CONTACTS (IN PLACE OF THE ZONE TEMP. SENSOR) FOR OPTIONAL ICE MACHINE CONTROL - OPTION "A".
 7. THE FOLLOWING CAPABILITIES ARE OPTIONAL - THEY ARE IMPLEMENTED AND WIRED AS REQUIRED FOR A SPECIFIC SYSTEM APPLICATION.
 - A ICE-MACHINE CONTROL (CANNOT BE USED WITH OPT. L)
 - B COMMUNICATIONS INTERFACE
 - D WYE-DELTA CLOSED TRANSITION STARTER
 - E CONTROL POWER TRANSFORMER
 - H UNIT DISCONNECT, NON-FUSED
 - J CHILLED WATER RESET - RETURN WATER
 - K CHILLED WATER RESET - OUTDOOR AIR
 - L CHILLED WATER RESET - ZONE AIR (CANNOT BE USED WITH OPT. A)
 - O LOW AMBIENT LOCKOUT
 - Q DELUXE CHILLER MODULE (1U) INCLUDES:
 - REMOTE ALARM/RUNNING/MAX CAPACITY CONTACTS
 - DISPLAY OF SE VOLTS
 - DISPLAY OF STARTS AND HOURS BY COMPRESSOR
 - UNDER/OVER VOLTAGE PROTECTION
 - S CHILLED WATER FLOW SWITCH (NOT REQUIRED FOR CHILLER PROTECTION)

WIRING AND CONTACT REQUIREMENTS:

20. ALL FIELD WIRING MUST BE IN ACCORDANCE WITH THE NATIONAL ELECTRICAL CODE (NEC), STATE AND LOCAL REQUIREMENTS. OUTSIDE THE UNITED STATES, OTHER COUNTRIES APPLICABLE NATIONAL AND/OR LOCAL REQUIREMENTS SHALL APPLY.
21. FOR CANADIAN INSTALLATION (CRA) ONLY, LOCAL INSPECTION AUTHORITIES MAY REQUIRE SINGLE PHASE SERVICE DISCONNECTING MEANS.
22. FOR UNITS WITHOUT THE CONTROL POWER TRANSFORMER (1T) OPTION, THE CUSTOMER MUST PROVIDE CONTROL POWER OF 115 VAC, 60 HERTZ, SINGLE PHASE, 750 VA ON 130 THRU 200 TON UNITS. THE CONTROL POWER TRANSFORMER (1T) IS STANDARD ON 50 HERTZ UNITS.
24. CUSTOMER SUPPLIED CONTACTS MUST BE COMPATIBLE WITH DRY CIRCUIT 120V, 25MA RESISTIVE LOAD, SILVER OR GOLD PLATED CONTACTS ARE RECOMMENDED.
25. 30 VOLT OR LESS CIRCUIT, DO NOT RUN IN CONDUIT WITH HIGHER VOLTAGE CIRCUITS. USE #14-18 AWG. SEE SELECTION TABLE.
26. MINIMUM CONTACT RATING AT 115 VAC: 8.5VA MIN/USH, 1.5VA SEALED.
27. FIELD WIRED ELECTRICAL LOADING IS NOT TO EXCEED THE FOLLOWING RATINGS:

TERMINALS	DEVICE	VOLTAGE	SEALED VA	MIN/USH VA
1U1-TB4-2.1	1U1K1,AND	115	115	1150+
1U1-TB4-2.3	1U1K1,AND	115	115	1150+
1U1-TB4-2.4	1U1K2,NO	115	115	1150+
1U1-TB4-2.6	1U1K2,NO	115	115	1150+

+ STANDARD FLDT DUTY RATING (30% POWER FACTOR).
28. WHEN CUSTOMER INPUT IS REQUIRED, REMOVE JUMPER AND INSTALL CUSTOMER WIRING.
29. AS SHIPPED 200/230V 60HZ AND 380/415V 50HZ UNIT TRANSFORMER (1T) (OPTIONAL) IS RATED FOR 200 AND 415 VOLT OPERATION RESPECTIVELY. IF UNIT IS TO BE OPERATED ON A 230 OR 380 VOLT SUPPLY, RE-CONNECT AS SHOWN IN INSET "D". IF THE CHILLER MODULE (1U1) UPGRADE (OPTION D) IS USED, CHANGE UCM FACTORY DISPLAY MENU ITEM 46 FROM 200V OR 415V TO 230V OR 380V RESPECTIVELY.
30. REQUIRED WIRING FOR BASIC UNIT OPERATION. ALL OTHER WIRING IS EITHER FOR OPTIONS OR AT THE CUSTOMERS DISCRETION.
31. 380V, 380/415V 50HZ, 380V, 460V, 575V 60HZ UNITS REQUIRE MAIN POWER CONNECTIONS ONLY TO 1TB1. 200/230V 60HZ UNITS REQUIRE MAIN POWER CONNECTIONS TO BOTH 1TB1 (CMT#1) AND 1TB2 (CMT#2). POWER WIRING ENTERS LOWER RIGHT HAND SIDE OF CONTROL PANEL.
32. ALL CUSTOMER CONTROL CIRCUIT WIRING MUST HAVE A MINIMUM RATING OF 180 VOLTS.
33. RECOMMEND USING 4 RUNS OF 2 CONDUCTOR, #18 AWG, 900V 60C, 100% SHIELDED WITH DRAIN WIRE (BELOW #19 OR EQUIVALENT) GROUND SHIELD DRAIN(S) AT THE UNIT CONTROL PANEL ONLY. 30 VOLT OR LESS CIRCUIT, DO NOT RUN IN CONDUIT WITH HIGHER VOLTAGE CIRCUITS.
34. RECOMMEND USING 2 RUN OF 8 CONDUCTOR, #22 AWG, 300V 60C, 100% SHIELDED WITH DRAIN WIRE (BELOW #20 OR EQUIVALENT) OR 6 RUNS OF 2 CONDUCTOR, #18 AWG, 300V 60C, 100% SHIELDED WITH DRAIN WIRE (BELOW #20 OR EQUIVALENT) GROUND SHIELD DRAIN(S) AT THE UNIT CONTROL PANEL ONLY. 30 VOLT OR LESS CIRCUIT, DO NOT RUN IN CONDUIT WITH HIGHER VOLTAGE CIRCUITS.
35. REFER TO INSTALLATION LABEL LOCATED INSIDE COVER OF REMOTE EVAPORATOR CONTROL PANEL.
36. FOR FIELD CONNECTION, CUT, STRIP, AND WIRE NUT EXISTING WIRE LOOP TO FIELD WIRING.
37. THE (3) RELAY CIRCUITS CAN BE PROGRAMMED TO PERFORM ALTERNATIVE FUNCTIONS. SEE RTAA-50W-3 FOR DETAILS. FUNCTION #1 IS SHOWN.

**Table 10
Electrical Data**

Unit Size	Unit Wiring					Motor Data						
	Rated Voltage	MCA (3) Ckt1/Ckt2(1)	MOP(2)	Rec Time Delay or RDE4)	Qty.	Comp. (Ea) RLA(5)	LRA(8)	Fans (Ea)				
								Qty. (11)	Qty. (12)	kW	FLA	kW(7)
RTAA 130	200	383/389	600/600	500/500	2	280/280	1689/1689	10	11	1.3	6.5	0.8
	230	383/389	600/600	500/500	2	280/280	1689/1689	10	11	1.3	6.5	0.8
	460	306	400	350	2	122/122	633/633	10	11	1.3	2.8	0.8
	575	246	300	300	2	98/98	512/512	10	11	1.3	2.3	0.8
RTAA 140	200	383/389	600/600	500/500	2	280/280	1689/1689	10	11	1.3	6.5	0.8
	230	383/389	600/600	500/500	2	280/280	1689/1689	10	11	1.3	6.5	0.8
	460	306	400	350	2	122/122	633/633	10	11	1.3	2.8	0.8
	575	246	300	300	2	98/98	512/512	10	11	1.3	2.3	0.8
RTAA 155	200	422/389	700/600	500/500	2	306/280	2044/1689	11	12	1.3	6.5	0.8
	230	422/389	700/600	500/500	2	306/280	2044/1689	11	12	1.3	6.5	0.8
	460	322	450	400	2	133/122	766/633	11	12	1.3	2.8	0.8
	575	260	350	300	2	107/98	611/512	11	12	1.3	2.3	0.8
RTAA 170	200	515/389	800/600	700/500	2	375/280	2391/1689	12	13	1.3	6.5	0.8
	230	515/389	800/600	700/500	2	375/280	2391/1689	12	13	1.3	6.5	0.8
	460	363	500	450	2	163/122	896/633	12	13	1.3	2.8	0.8
	575	292	400	350	2	131/987	25/512	12	13	1.3	2.3	0.8
RTAA 185	200	515/428	800/700	700/600	2	375/306	2391/2044	13	14	1.3	6.5	0.8
	230	515/428	800/700	700/600	2	375/306	2391/2044	13	14	1.3	6.5	0.8
	460	376	500	450	2	163/133	896/766	13	14	1.3	2.8	0.8
	575	303	400	350	2	131/107	725/611	13	14	1.3	2.3	0.8
RTAA 200	200	514/514	800/800	700/700	2	375/375	2391/2391	14	14	1.3	6.5	0.8
	230	514/514	800/800	700/700	2	375/375	2391/2391	14	14	1.3	6.5	0.8
	460	406	500	450	2	163/163	896/896	14	14	1.3	2.8	0.8
	575	327	450	400	2	131/131	725/725	14	14	1.3	2.3	0.8
RTAA 240	460	303/224	400/350	350/300	3	122-122/163	633-633/896	N/A	17	1.3	2.8	1.0
	575	244/180	300/300	300/225	3	98-98/131	512-512/725	N/A	17	1.3	2.3	1.0
RTAA 270	460	360/224	500/350	450/300	3	163-122/163	896-633/896	N/A	19	1.3	2.8	1.0
	575	290/180	400/300	350/225	3	131-98/131	725-512/725	N/A	19	1.3	2.3	1.0
RTAA 300	460	406/224	500/350	450/300	3	163-163/163	896-896/896	N/A	21	1.3	2.8	1.0
	575	327/180	450/300	400/225	3	131-131/131	725-725/725	N/A	21	1.3	2.3	1.0
RTAA 340	460	303/406	400/500	350/450	4	122-122/163-163	633-633/896-896	N/A	24	1.3	2.8	1.0
	575	244/327	300/450	300/400	4	98-98/131-131	512-512/725-725	N/A	24	1.3	2.3	1.0
RTAA 370	460	360/406	500/500	450/450	4	163-122/163-163	896-633/896-896	N/A	26	1.3	2.8	1.0
	575	290/327	400/450	350/400	4	131-98/131-131	725-512/725-725	N/A	26	1.3	2.3	1.0
RTAA 400	460	406/406	500/500	450/450	4	163-163/163-163	896-896/896-896	N/A	28	1.3	2.8	1.0
	575	327/327	450/450	400/400	4	131-131/131-131	725-725/725-725	N/A	28	1.3	2.3	1.0

Notes:

- (1) Low voltage units (200 & 230 volt) require separate power connections for each circuit.
- (2) MOP - Maximum Overcurrent Protection - may be either fused (UL/CSA) or with circuit breakers (CSA only).
MOP = 225 percent of the largest compressor RLA plus 100 percent of the second compressor RLA plus the sum of the condenser fans FLAs per NEC 440-22.
- (3) MCA - Minimum Circuit Ampacity - 125 percent of largest compressor RLA plus 100 percent of second compressor plus the sum of the condenser fans FLAs per NEC 440-33.
- (4) RECOMMENDED TIME DELAY OR DUAL ELEMENT (RDE) FUSE SIZE: 150 percent of the largest compressor RLA plus 100 percent of the second compressor RLA and the sum of the condenser tan FLAs.
- (5) RLA - Rated Load Amps - rated in accordance with UL Standard 465.
- (6) Local codes may take precedence.
- (7) Control kW includes operational controls only. Does not include heat tapes.
- (8) LRA - Locked Rotor Amps - based on full winding start units.
- (9) VOLTAGE UTILIZATION RANGE:

Rated Voltage	Utilization Range
200	180-220
230	208-254
460	414-506
575	516.633
- (10) A 11 5/60/1, 15 amp. customer provided power connection is required to operate the unit controls. A separate 115(60/1, 15 amp. customer provided power connection is also needed to power the evaporator heat tape (RTAA 130-200 = 420 watts, RTAA 240-400 = 840 watts @ 120 volts) and optional Domestic Water Heater (420 watts @ 120 volts.). If the optional control power is used, the customer needs only to provide a power connection for the heat tapes.
- (11) 15 F minimum starting/operating ambient.
- (12) 0 F minimum starting/operating ambient

Installer-Supplied Components

Caution: Customer wiring interface connections are shown in the electrical schematics and connection diagrams that are shipped with the unit.

The installer must provide the following components if not ordered with the unit:

- [] Power supply wiring (in conduit) for all field-wired connections.
- [] All control (interconnecting) wiring (in conduit) for field supplied devices.
- [] Fused-disconnect switches.
- [] Power factor correction capacitors.

Remote Evaporator Only:

Control wiring between the outdoor unit and the evaporator terminal box.

Power Supply Wiring

General

All power supply wiring must be sized and selected accordingly by the project engineer in accordance with NEC Table 31016.

WARNING: To prevent injury or death, disconnect electrical power source before completing wiring connections to the unit.

All wiring must comply with local codes and the National Electrical Code. The installing (or electrical) contractor must provide and install the system interconnecting wiring, as well as the power supply wiring. It must be properly sized and equipped with the appropriate fused disconnect switches. The type and installation location(s) of the fused disconnects must comply with all applicable codes.

Caution: Use only copper conductors for terminal connections to avoid corrosion or overheating.

Remove the plate on the lower right side of the power connection panel and cut holes for the appropriately-sized wiring conduits. The wiring is passed through these conduits and connected to the terminal blocks or optional unit-mounted disconnect. Refer to Figure 1 and Figures 34 thru 36.

To provide proper phasing of 3-phase input, make connections as shown in Figures 34 thru 36 and as stated on the yellow WARNING label in the starter panel. For additional information on proper phasing, refer to "Unit Voltage Phasing Proper equipment ground must be provided to each ground connection in the panel (one on 460/575 volt units and two on 200/230 volt units).

⚠ CAUTION:
IT IS IMPERATIVE THAT L1-L2-L3 IN THE STARTER BE CONNECTED IN THE A-B-C PHASE SEQUENCE TO PREVENT EQUIPMENT DAMAGE DUE TO REVERSE ROTATION.

Control Power Supply

If the unit is equipped with the optional control power transformer, it is not necessary to provide control power voltage to the unit.

Caution: 200/230 volt units are factory connected as 200 volt units. For 230 volt units, the leads must be moved to the appropriate terminals on the transformer (1T1). See Unit Wiring Diagrams.

If the transformer is not provided, connect control power (115V, 750VA, 15 amp maximum fuse size) to terminals 1TB3-1 and 1TB3-2, on 130-200 units. Use 1TB3-1 and 1TB4-1 on 240-400 units.

Heat Tape Power Supply (Packaged Units Only)

Note: Units with the Remote Evaporator option do not have heat tape.

The evaporator shell and optional Domestic Water Heater are insulated from ambient air and protected from freezing temperatures by a thermostatically-controlled heat tape. Whenever the water temperature drops to approximately 37 F, the thermostat energizes the heat tape. The heat tape will provide protection from ambient temperatures down to -20 F.

Provide an independent power source (115V, 15 amp), with a fused-disconnect. The heat tape is factory wired back to the unit control panel. Customer connections are made on terminal strip 1TB3-11 and 1TB3-12 on 130-200 units or 1TB3-10 and 1TB4-1 0 on 240-400 units.

Water Pump Power Supply

Provide power supply wiring with fused disconnect for the chilled water pump(s).

Auxiliary Heat Tape Power Supply

Provide power wiring and properly sized fused-disconnect for any electrical heat tape installed on the system water piping.

Interconnecting Wiring

Chilled Water Pump Interlock and External Auto/Stop for Model RTAA Air-Cooled Series R CenTraVac

Caution: The following must be adhered to or equipment damage may occur.

The Model RTAA Series R chiller requires a minimum of two field-supplied control inputs:

- Chilled water pump interlock (TB3-1, -2 on the 1U1 board).
- External Auto/Stop (T133-3, -4 on the 1U1 board)

When there is a command to shut down the chilled water system, the chilled water pump is required to operate for a minimum of one minute after the External AUTO/STOP gives the shutdown command.

Normally, when the compressors are terminating a cycle (via chiller Stop/Reset switch, loss of load, Low Ambient Run Inhibit or External Auto/Stop), the controller will initiate the "Run:Unload" mode. This operating mode energizes the unload solenoid for 20 seconds, to unload the compressor so that it will be unloaded for the next start-up. Then the master oil solenoid is de-energized and closure of the master oil solenoid is verified. The entire process may take up to 40 seconds.

If the chilled water pump interlock is used without the external Auto/Stop input, the chiller will shut down immediately upon the command for shut down, without initiating the "Run:Unload" mode. This is considered a "non-friendly" shut down and a "Machine Auto Reset" diagnostic will be displayed on the LICK

Caution: The method in the previous paragraph is not to be used as a normal means of cycling the chiller off, e.g. time clock, building automation system, etc.

The proper method for cycling the chiller off is to open a set of contact between TB3-3, -4 on the 1U1 board (External Auto/Stop). Then, following a one minute delay, the chilled water pump is cycled off. Chilled water flow indication should be provided between TB3-1, -2 on the 1U1 board, e.g. water pump motor starter auxiliaries and/or flow switch.

The wiring for this recommendation is shown in the furnished electrical schematics and connection diagrams. Relay 5DL1 is a normally-open, instantaneous close, timed open (1 min.) time delay relay. An alternative solution is to provide proper programming in a building automation system.

Chilled Water Pump Interlock

The installer must provide leads 520 and 521 from the chilled water pump (5B1) starter auxiliary (5K1) to the proper terminals of terminal strip 1U1 TB3 on the UCM, as shown in Figures 34 thru 36. Circuit requirement is 115 VAC, with minimum contact rating @ 115 VAC of 6.9 VA inrush, 1.3 VA sealed. Refer to the field diagrams which are shipped with the unit.

The auxiliary contact of the chilled water pump may be wired in series with an optional flow switch, as shown. The standard UCM provides internal protection for the unit against loss of chilled water flow. Also refer to "Evaporator Flow Switch."

External Auto/Stop Wiring

If the unit requires the Auto/Stop function, the installer must provide leads 522 and 523 from the remote contacts (5K5, 5K21) to the proper terminals of the terminal strip 1U1 TB3 on the UCM, as shown in Figures 34 thru 36.

The chiller will run normally when the contacts are closed. When either contact opens, the compressor(s), if operating, will go to the RUN:UNLOAD operating mode and cycle off. Unit operation will be inhibited. Re-closure of the contacts will permit the unit to automatically return to normal operation.

Circuit requirements are 2-wire, 115 VAC, with minimum contact rating @ 115 VAC of 6.9 VA inrush, 1.3 VA sealed. Refer to the field diagrams which are shipped with the unit.

Alarm/Running/Maximum Capacity Outputs

Terminals 1 to 8 on terminal strip TB4 of the 1U1 board provide a variety of contact outputs. These are dependent upon the setting of Menu Item 4E and its relationship to diagnostics, compressors operating and the system operating at full capacity.

Table 11
Alarm/Running/Maximum Capacity Relay Output Configurations

Relay Output Configuration
1: RLY 1 = Alarm RLY 2 = Compressor Running RLY 3 = Maximum Capacity
2: RLY 1 = Circuit 1 Alarm RLY 2 = Circuit 2 Alarm RLY 3 = Maximum Capacity
3: RLY 1 = Alarm RLY 2 = Circuit 1 Running RLY 3 = Circuit 2 Running

As shown in Figure 37, there are three relays. Relays 1 and 2 have SPDT contacts. Relay 3 has SPST normally open contacts. The relays can provide three different output configurations, as shown in Table 11, and each configuration offers four choices as to how the alarm relay is to respond to a set of diagnostics.

Table 12 shows the twelve settings available in Menu Item 4E and the diagnostics which are issued for each set of conditions.

Figure 37
Alarm/Running/Maximum Capacity Contact Outputs

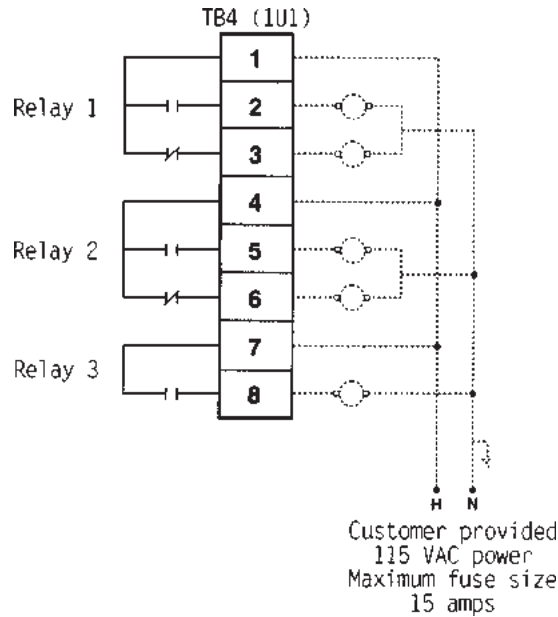

Table 12
Alarm/Running/Maximum Capacity Menu Settings

Menu Item 4E Setting	Relays Output Configuration (Table 11)	Diagnostics that the Alarm Relay(s) is Active		
		MMR/CMR diag.	MAR/CAR diag.	IFW diag.
1	1	YES	NO	NO
2	1	YES	YES	NO
3	1	YES	YES	YES
4	1	YES	NO	YES
5	2	YES	NO	NO
6	2	YES	YES	NO
7	2	YES	YES	YES
8	2	YES	NO	YES
9	3	YES	NO	NO
10	3	YES	YES	NO
11	3	YES	YES	YES
12	3	YES	NO	YES

Notes:
MMR = Machine Manual Reset
CMR = Circuit Manual Reset
MAR = Machine Auto Reset
CAR = Circuit Auto Reset
IFW = Informational Warnings

Alarm/Running/Maximum Capacity Indicator Wiring

If the optional remote Alarm/Running/Maximum Capacity contacts are used, provide electrical power, 115 VAC (contact load not to exceed 1150 VA inrush, 115 VA sealed), with fused-disconnect to a customer-furnished remote device. Also provide proper remote device ground connection.

To install the available remote running and alarm indication, the installer must provide leads 525 thru 532 from the panel to the proper terminals of terminal strip 1U1TB4 on the UCM, as shown in Figures 31 thru 32. Refer to the field diagrams which are shipped with the unit.

Low Voltage Wiring

The remote devices described below require low voltage wiring. All wiring to and from these remote input devices to the UCM must be made with shielded, twisted pair conductors. Be sure to ground the shielding only at the UCM. See Figures 34 thru 36 for the recommended conductor sizes.

Caution: To prevent control malfunctions, do not run low voltage wiring (<30 V) in conduit with conductors carrying more than 30 volts.

Emergency Stop (Normal Trip)

The UCM provides auxiliary control for a customer specified/installed latching tripout. When this customer-furnished remote contact (5K18) is provided, the chiller will run normally when the contact is closed. When the contact opens, the unit will trip off on a manually resettable diagnostic. This condition requires manual reset at the chiller switch on the front of the UCM.

To connect, first remove the jumper located between terminals 3 and 4 of 1U1,TB1 on the UCM. Connect low voltage leads 513 and 514 to those terminals. Terminal strip locations are shown in Figures 34 thru 36. Refer to the field diagrams which are shipped with the unit.

Silver or gold-plated contacts are recommended. These customer-furnished contacts must be compatible with 12 VDC, 45 mA resistive load.

External Circuit Lockout – Circuit #1

The UCM provides auxiliary control of a customer specified or installed contact closure, for individual operation of Circuit #1. If the contact is open, the refrigerant circuit will not operate. Upon closure, the refrigerant circuit will run normally. This feature is used to restrict total chiller operation, e.g. during emergency generator operations.

External circuit lockout will only function if menu item 3b is enabled.

These customer-supplied contact closures must be compatible with 12 VDC, 45 mA resistive load. Silver or gold plated contacts are recommended.

RTAA 130-200

To install, cut, strip and wire-nut existing wire loop #W59 on the P43 connector of the 1U4 module to low voltage leads 45A and 45B. Connections are shown in the field diagrams which are shipped with the unit.

RTAA 240-400

To install, cut, strip and wire-nut existing wire loop #W53 on the P43 connector of the 1U4 module to low voltage leads 568 and 569. Connections are shown in the field diagrams which are shipped with the unit.

External Circuit Lockout – Circuit #2

The UCM provides auxiliary control of a customer specified or installed contact closure, for individual operation of Circuit #2. If the contact is open, the refrigerant circuit will not operate. Upon closure, the refrigerant circuit will run normally. This feature is used to restrict total chiller operation, e.g. during emergency generator operations.

These customer-supplied contact closures must be compatible with 12 VDC, 45 mA resistive load. Silver or gold plated contacts are recommended.

External circuit lockout will only function if menu item 3b is enabled.

RTAA 130-200

To install, cut, strip and wire-nut existing wire loop #W60 on the P53 connector of the 1U5 module to low voltage leads 46A and 46B. Connections are shown in the field diagrams which are shipped with the unit.

RTAA 240-400

To install, cut, strip and wire-nut existing wire loop #W55 on the P63 connector of the 1U6 module to low voltage leads 566 and 567. Connections are shown in the field diagrams which are shipped with the unit.

Ice Making Option

Menu Item 32 must be Enabled. The UCM provides auxiliary control for a customer specified/installed contact closure for ice making. When contact (5K20) is provided, the chiller will run normally when the contact is open. Upon contact closure, the UCM will initiate an ice-building mode, in which the unit runs fully loaded at all times. Ice-building shall be terminated either by opening the contact or based on the entering evaporator water temperature (Menu Item 33 = Setpoint). The UCM will not permit the ice-building mode to be reentered until the unit has been switched out of ice-building mode (open 5K20 contacts) and then switched back into ice-building mode (close 5K20 contacts.)

In ice-building, both the 1.5 F/min. pulldown rate limit and freeze avoidance will be ignored and the current unit setpoint will be set at 120%. For example, if the Front Panel or External Current Limit setpoint is set to 80%, in ice-building the Active Current Limit is 120%.

If, while in ice-building mode, the unit gets down to the freezestat setting (water or refrigerant), the unit will shut down on a manually resettable diagnostic, just as in normal operation.

Connect leads 501 and 502 from 5K20 to the proper terminals of 1U2,TB1 on the UCM, as shown in Figures 34 thru 36. Refer to the field diagrams which are shipped with the unit.

Silver or gold-plated contacts are recommended. These customer furnished contacts must be compatible with 12 VDC, 45 mA resistive load.

External Chilled Water Setpoint (CWS): Remote Resistor/Potentiometer, Voltage Source 2-10 VDC, or Current Source 4-20 mA

This option allows the external setting of the Chilled Water Setpoint, independent of the Front Panel Chilled Water Setpoint, by one of three means:

1. A remote resistor/potentiometer input (fixed or adjustable)

2. An isolated voltage input 2-10 VDC
3. An isolated current loop input 4-20 mA

Methods 2 and 3 are usually used in interfacing with a Generic BAS or a process controller to the chiller.

To enable external setpoint operation, Item 30 of Menu 3, "External Chilled Water Setpoint d/E", should be set to "E" using the Front Panel Operator Interface.

1. Remote Resistor/Potentiometer Input (fixed or adjustable)

Connect the remote resistor and/or potentiometer to terminals TB1 -3 and TB1 -5 of Options Module 1U2, as shown in Figure 38.

For units with 40 F to 60 F LCWS range, a field-furnished 25 Kohm linear taper potentiometer ($\pm 10\%$) and a fixed 5.6 Kohm ($\pm 10\%$) 1/4 watt resistor should be used.

For units with 20 F to 39 F LCWS range, a field-furnished 25 Kohm linear taper potentiometer ($\pm 1\%$) and a fixed 15 Kohm ($\pm 1\%$) 1/4 watt resistor should be used.

If the potentiometer is to be remotely mounted, it and the resistor must be connected to the UCM prior to mounting. Then, with the UCM display in Menu 0 and the display advanced to "Active Chilled Water Setpoint", the UCM can be used to calibrate the positions of the potentiometer to correspond with the desired settings for the leaving water temperature. External resistor input values for various chilled water setpoints are shown in Table 13.

**Figure 38
Resistor and Potentiometer Arrangement for External Chilled Water Setpoint**

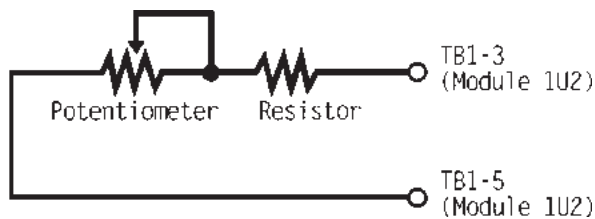

**Table 13
Input Values Vs. External Chilled Water Setpoint**

Inputs			Resulting Chilled Water Setpoint (F)
Resistance (Ohms)	Current (mA)	Voltage (Vdc)	
94433	4.0	2.0	0.0
68609	5.2	2.6	5.0
52946	6.5	3.2	10.0
42434	7.7	3.9	15.0
34889	8.9	4.5	20.0
29212	10.2	5.1	25.0
24785	11.4	5.7	30.0
21236	12.6	6.3	35.0
18327	13.8	6.9	40.0
15900	15.1	7.6	45.0
13844	16.3	8.2	50.0
12080	17.5	8.8	55.0
10549	18.8	9.4	60.0
9050	20.0	10.0	65.0

2. Isolated 2-10 VDC Voltage Source Input

Set DIP Switch SW1-1 of Options Module 1U2 to "OFF". Connect the voltage source to terminals TB1 -4 (+) and TB1 -5 (-) on Options Module 1U2. CWS is now based on the following equation:

$$CW \text{ Setpoint } 0 F = (VDC \times 8.125) - 16.25$$

Sample values for CWS vs. VDC signals are shown in Table 13.

Minimum setpoint = 0 F (2.0 VDC input)

Maximum setpoint = 65 F (9.4 VDC input)

Maximum continuous input voltage = 15 VDC

Input impedance = 40.1 Kohms (SW1 -1 off)

3. Isolated 4-20 mA Current Source Input

Set DIP Switch SW1-1 of Options Module 1U2 to "ON". Connect the current source to terminals TB1-4 (+) and TB1-5 (-). CWS is now based on the following equation:

$$\text{Setpoint } ^\circ F = (mA \times 4.0625) - 16.25$$

Sample values for CWS vs. mA signals are shown in Table 13.

Minimum setpoint = 0 F (4.0 mA)

Maximum setpoint = 65 F (18.8 mA)

Maximum continuous = 30 mA input current

Input impedance = 499 ohms (SW1 -1 on)

Note: The negative terminal TB1 -5 is referenced to the UCM chassis ground. To assure correct operation, 2-10 VDC or 4-20 mA signals must be isolated or "floating" with respect to the UCM chassis ground. See Figures 34 thru 36.

External Current Limit Setpoint (CLS): Remote Resistor/Potentiometer, Voltage Source 2-10 VDC or Current Source 4-20 mA

This option allows the external setting of the Current Limit Setpoint, independent of the Front Panel Current Limit Setpoint, by one of three means:

1. A remote resistor/potentiometer input (fixed or adjustable)
2. An isolated voltage input 2-10 VDC
3. An isolated current loop input 4-20 mA

Methods 2 and 3 are usually used in interfacing with a Generic BAS.

To enable external Current Limit Setpoint operation, Item 31 of Menu 3, "External Current Limit Setpoint WE", should be set to "E" using the Front Panel Operator Interface.

1. Remote Resistor/Potentiometer Input

To cover the entire range of Current Limit Setpoints; (40 to 120%), a field furnished 50 Kohm log taper potentiometer ($\pm 10\%$) and a fixed 820 ohm ($\pm 10\%$) 1/4 Watt resistor should be wired in series and connected to terminals TB1 -6 and TB1 -8, of options module 1U2, as shown in Figure 39.

Table 14
Input Values Vs. External Current Limit Setpoint

Inputs			Resulting Current Limit Setpoint (% RLA)
Resistance (Ohms)	Current (mA)	Voltage (Vdc)	
49000	4.0	2.0	40
29000	6.0	3.0	50
19000	8.0	4.0	60
13000	10.0	5.0	70
9000	12.0	6.0	80
6143	14.0	7.0	90
4010	16.0	8.0	100
2333	18.0	9.0	110
1000	20.0	10.0	120

Figure 39
Resistor and Potentiometer Arrangement for External Current Limit Setpoint

50K Ohm $\pm 10\%$ Log CCW Potentiometer

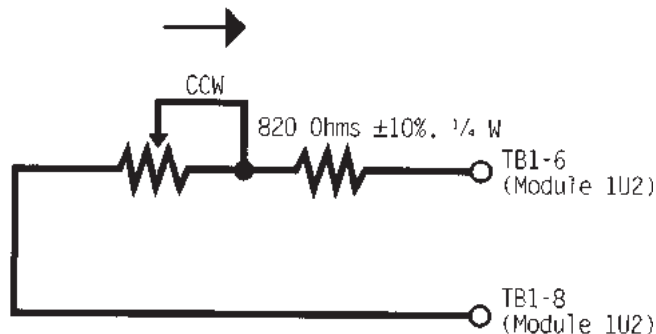

If the potentiometer is to be remotely mounted, it and the resistor must be connected to the UCM prior to mounting. Then, with the UCM display in Menu 0 and the display advanced to "Active Current Limit Setpoint", the UCM can be used to calibrate the positions of the potentiometer to correspond with the desired settings for the current limits. External resistor input values for various current limit setpoints are shown in Table 14.

2. 2-10 VDC Voltage Source Input

Set DIP Switch SW1-2 of Options Module 1U2 to "OFF". Connect the voltage source to terminals TB1 -7 (+) and TB1 -8 (-) of Options

Module 1U2. CLS is now based on the following equation:

$$CL \text{ Setpoint } \% = (\text{VDC} \times 10) + 20$$

Sample values for CLS vs. VDC signals are shown below:

Minimum setpoint

$$= 40\% (2.0 \text{ VDC input})$$

Maximum setpoint

$$= 120\% (10.0 \text{ VDC input})$$

Maximum continuous input voltage

$$= 15 \text{ VDC}$$

Input impedance = 40.1 Kohms

(SW1 -2 off)

3. 4-20 mA Current Source Input

Set DIP Switch SW1-2 of Options Module 1U2 to "ON". Connect the current source to terminals TB1 -7 (+) and TB1 -8 (-) of Options Module 1U2. CLS is now based on the following equation:

$$CL \text{ Setpoint } \% = (\text{mA} \times 5) + 20$$

Sample values for CLS vs. mA signals are shown in Table 14.

Minimum setpoint = 40% (4.0 mA)

Maximum setpoint = 120% (20.0 mA)

Maximum continuous input current = 30 mA

Input impedance = 499 ohms (SW1 - 2 on)

Note: The negative terminal TB1 -8 is referenced to the UCM chassis ground. To assure correct operation, 2-10 VDC or 4-20 mA signals must be isolated or "floating" with respect to the UCM chassis ground. See Figures 31 thru 32.

Optional Bidirectional Communications Link (BCL)

This option allows the UCM in the control panel to exchange information (e.g. operating setpoints and Auto/Standby commands) with a higher level control device, such as a Tracer, a multiple-machine controller or a remote display panel. A shielded, twisted-pair connection establishes the bidirectional communications link between the unit control panel and the Tracer, multiple-machine controller or remote display panel.

Note: The shielded, twisted-pair conductors must run in a separate conduit.

Caution: To prevent control malfunctions, do not run low voltage wiring (<30 V) in conduit with conductors carrying more than 30 volts.

General

Field wiring for the communication link must meet the following requirements:

1. All wiring must be in accordance with the NEC and local codes.
2. Communication link wiring must be 18 AWG shielded, twisted-pair wiring (Belden 8760, or equivalent).
3. The maximum total wire length for each communication link is 5,000 feet.
4. The communication link cannot pass between buildings.
5. All UCM's on the communication link can be connected in a "daisy chain" configuration.

Communication Link Connection Procedure

1. Refer to the Tracer installation literature to determine proper communication link termination connections at the Tracer unit.
2. Refer to RTAA-IOM-2 for installation/operation of Remote Display Panel.
3. Connect the shield of the communication link wiring to the designated shield terminal at the Tracer unit.
4. Connect leads 561 and 562 from the proper terminals of 1U2, TB2 on the UCM to the Tracer, as shown in Figures 31 thru 33. There is no polarity requirement for this connection.
5. At the UCM the shield should be cut and taped to prevent any contact between the shield and ground. See Figures 31 thru 33.

Note: On multiple-unit installations, splice the shielding of the two twisted-pairs that come into each UCM in the "daisy chain" system. Tape the spliced connections to prevent any contact between the shield and ground. At the last UCM in the chain, the shield should be cut and taped off.

6. For unit ICS address selection see menu item "4C".

Installation Check List

Complete this checklist as the unit is installed, to verify that all recommended procedures are accomplished **before** the unit is started. **This checklist does not replace the detailed instructions given in the "Installation -Mechanical" and "Installation -Electrical" sections of this manual.** Read both sections completely, to become familiar with the installation procedures, prior to beginning the work.

Receiving

- [] Verify that the unit nameplate data corresponds to the ordering information.
- [] Inspect the unit for shipping damage and any shortages of materials. Report any damage or shortage to the carrier.

Unit Location and Mounting

- [] Inspect the location desired for installation and verify adequate service access clearances.
- [] Provide drainage for evaporator water.
- [] Remove and discard all shipping materials (cartons, etc.)
- [] Install optional spring isolators, if required.
- [] Level the unit and secure it to the mounting surface.

Unit Piping

- [] Flush all unit water piping before making final connections to the unit.

Caution: If using an acidic commercial flushing solution, construct a temporary bypass around the unit to prevent damage to internal components of the evaporator.

Caution: To avoid possible equipment damage, do not use untreated or improperly treated system water.

- [] Connect the chilled water piping to the evaporator.
- [] Install pressure gauges and shutoff valves on the chilled water inlet and outlet to the evaporator.
- [] Install a water strainer in the entering chilled water line.
- [] Install a balancing valve and flow switch (discretionary) in the leaving chilled water line.
- [] Install a drain with shutoff valve or a drain plug on the evaporator.
- [] Vent the chilled water system at high points in the system piping.
- [] Apply heat tape and insulation, as necessary, to protect all exposed piping from freeze-up.

Electrical Wiring

WARNING: To prevent injury or death, disconnect electrical power source before completing wiring connections to the unit.

Caution: To avoid corrosion and overheating at terminal connections, use copper conductors only.

- [] Connect the unit power supply wiring with fused-disconnect to the terminal block (or unit-mounted disconnect) in the power section of the control panel.
 - [] Connect the control power supply wiring with fused-disconnect to the terminal strip in the power section of the control panel.
 - [] Connect power supply wiring to the evaporator heat tape. Connect leads 551 and 552 to terminals 11 and 12 of terminal strip 1TB3.
 - [] Connect power supply wiring to the chilled water pump.
 - [] Connect power supply wiring to any auxiliary heat tapes.
 - [] Connect the auxiliary contact of the chilled water pump (5K1) in series with the optional flow switch, if installed, and then connect to the proper terminals.
 - [] For the External Start/Stop function, install wiring from remote contacts (5K5, 5K21) to the proper terminals on terminal strip 1U1TB3.
- Caution: Information in Interconnecting Wiring: Chilled Water Pump Interlock and External Auto/Stop must be adhered to or equipment damage may occur.**
- [] If the remote alarm/running/maximum capacity contacts are used, install leads 525 thru 532 from the panel to the proper terminals on terminal strip 1U1TB4.
 - [] If the emergency stop function is used, install low voltage leads 513 and 514 to terminals 3 and 4 of 1U1TB1.
 - [] If indoor zone temperature is to be used, install leads 501 and 502 on 6RT4 to the proper terminals on 1U2TB1.
 - [] If the ice making-option is used, install leads 501 and 502 on 5K20 to the proper terminals on 1U2TB1.



Operating Principles – Mechanical

General

This section describes the mechanical operating principles of Series R air-cooled chillers equipped with microcomputer-based control systems.

The 130 thru 400-ton Model RTAA units are dual-circuited, helical-rotary type air-cooled liquid chillers. The basic components of an RTAA unit are:

- Unit Control Module (UCM)
- Unit-mounted panel
- Helical-rotary compressor
- Direct Expansion evaporator
- Air-cooled condenser
- Oil supply system (hydraulic and lubrication)
- Interconnecting piping

Components of a typical RTAA unit are identified in Figures 1 thru 6.

Refrigeration (Cooling) Cycle

Cycle Description

Figures 40 and 41 represent the refrigeration system and control components. Vaporized refrigerant leaves the evaporator and is drawn into the compressor. Here it is compressed and leaves the compressor as a mixture of hot gas and oil (which was injected during the compression cycle).

The mixture enters the oil separator at the two in/out caps. The separated oil flows to the bottom of the separator, while the refrigerant gas flows out the top and passes on to the tubes in the condensing coils. Here circulating air removes heat from the refrigerant and condenses it.

The condensed refrigerant passes through the electronic expansion valve and into the tubes of the evaporator. As the refrigerant vaporizes, it cools the system water that surrounds the tubes in the evaporator.

Compressor Description

The compressors used by the Model RTAA Series “R” Air-cooled chiller consists of two distinct components: the motor and the rotors. Refer to Figure 42.

Compressor Motor

A two-pole, hermetic, squirrel-cage induction motor directly drives the compressor rotors. The motor is cooled by suction refrigerant gas from the evaporator, entering the end of the motor housing through the suction line, as shown in Figures 40 and 41.

Compressor Rotors

The compressor is a semi-hermetic, direct drive helical rotary type compressor. Each compressor has only three moving parts: Two rotors - “male” and “female” - provide compression, and a slide valve controls capacity. See Figure 42. The male rotor is attached to, and driven by, the motor, and the female rotor is, in turn, driven by the male rotor. Separately housed bearing sets are provided at each end of both rotors. The slide valve is located above, and moves along, the top of the rotors.

The helical rotary compressor is a positive displacement device. The refrigerant from the evaporator is drawn into the suction opening at the end of the motor barrel, through a suction strainer screen, across the motor, and into the intake of the compressor rotor section. The gas is then compressed and discharged directly into the discharge line.

There is no physical contact between the rotors and compressor housing. The rotors contact each other at the point where the driving action between the male and female rotors occurs. Oil is injected along the top of the compressor rotor section, coating both rotors and the compressor housing interior. Although this oil does provide rotor lubrication, its primary purpose is to seal the clearance spaces between the rotors and compressor housing.

A positive seal between these internal parts enhances compressor efficiency by limiting leakage between the high pressure and low pressure cavities.

Capacity control is accomplished by means of a slide valve assembly located in the rotor section of the compressor. Positioned along the top of the rotors, the slide valve is driven by a piston/cylinder along an axis that parallels those of the rotors.

Compressor load condition is dictated by the position of the slide valve over the rotors. When the slide valve is fully extended over the rotors and away from the discharge end, the compressor is fully loaded. Unloading occurs as the slide valve is drawn towards the discharge end. Slide valve unloading lowers refrigeration capacity by reducing the compression surface of the rotors.

Compressor Loading Sequence

When there is a call for chilled water, the UCM will start the compressor which has the least number of starts. If the first compressor cannot satisfy the demand, the UCM will start another compressor and then balance the load on all compressors by pulsing the load/unload solenoids.

The load on the compressors will be kept in balance, as load fluctuates, until the demand for chilled water is reduced to a level that can be handled by one compressor. At this time, the UCM will drop off the compressor that has the greatest number of operating hours and will adjust the load on the other compressor, as required.

Figure 40
 Refrigeration System and
 Control Components
 Single Circuit

(Continued on Next Page)

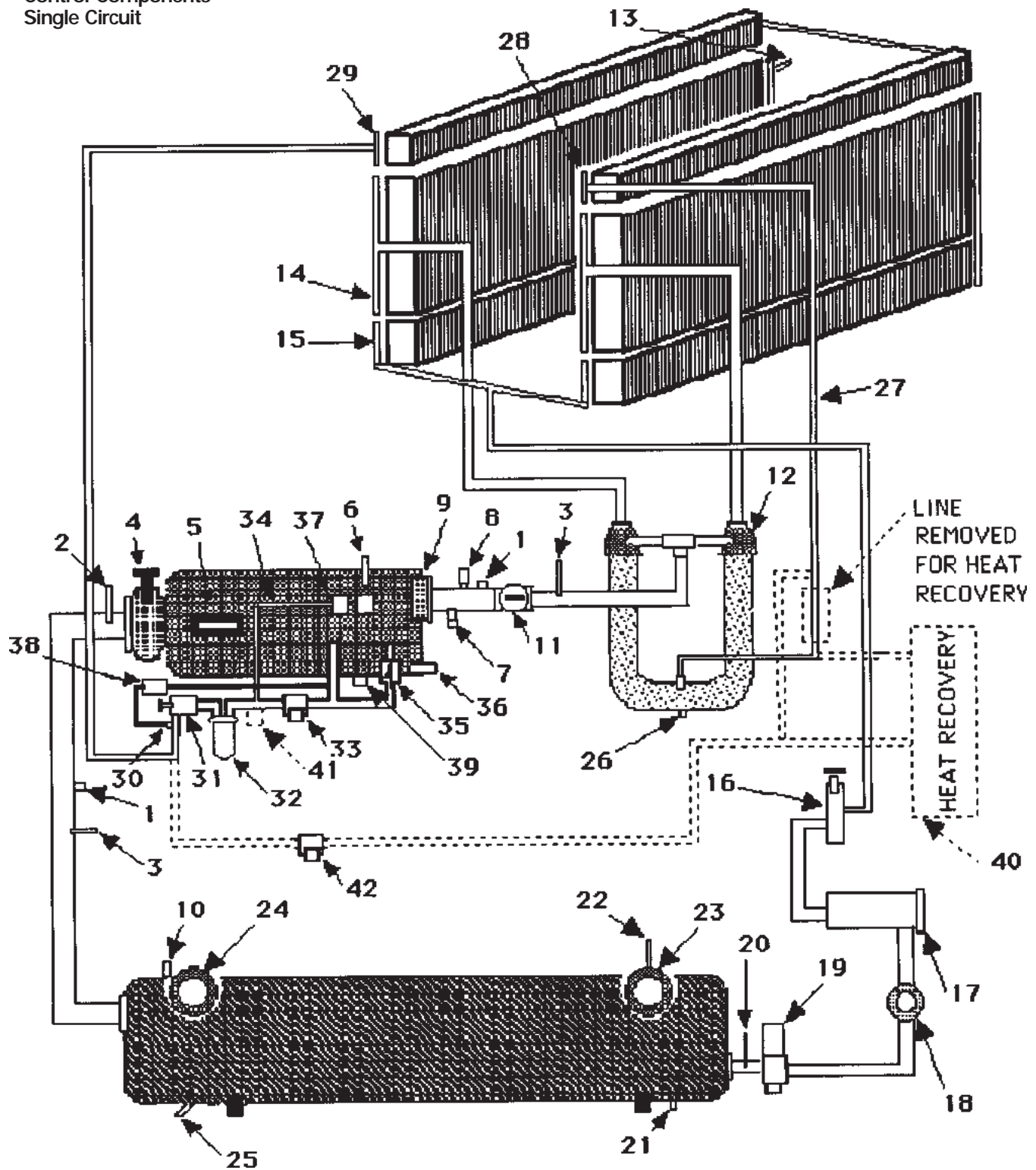

Figure 40

(Continued from Previous Page)

- 1 Schrader valve
- 2 Suction temperature sensor*
- 3 Manufacturing process tube
- 4 Suction service valve (optional)
- 5 Motor winding thermostat*
- 6 Discharge temperature sensor*
- 7 Pressure relief valve (450 psi)
- 8 High pressure cutout (405 psi)*
- 9 Discharge check valve
- 10 Evaporator waterside vent
- 11 Discharge line shutoff valve
- 12 Oil separator in/out cap
- 13 Saturated condensing temperature sensor*
- 14 Condenser header
- 15 Subcooler header
- 16 Liquid line shutoff valve

- 17 25 micron filter/drier
- 18 Liquid line sight glass
- 19 Electronic expansion valve
- 20 Saturated evaporator temperature sensor*
- 21 Evaporator waterside drain
- 22 Leaving water temperature sensor*
- 23 Leaving water connection
- 24 Entering water connection
- 25 Entering water temperature sensor*
- 26 Drain with Schrader valve
- 27 Oil line
- 28 Entering oil cooler header
- 29 Leaving oil cooler header
- 30 Schrader valve with stem depressor
- 31 Oil line shutoff valve
- 32 5 micron oil filter

- 33 Master solenoid valve*
 - 34 Oil line to load/unload slide valve solenoids
 - 35 Injection oil check valve
 - 36 Heater
 - 37 Slide valve solenoids and orifices*
 - 38 Oil flow differential pressure switch*
 - 39 Compressor Drain Plug
 - 40 Domestic water heater (option)
 - 41 Oil line thermostat (option, Domestic Water Heater)
 - 42 Oil line bypass solenoid valve (option, Domestic Water Heater)
- *UCM Input/Output Control

Figure 41
Refrigeration System and
Control Components
Duplex Circuit

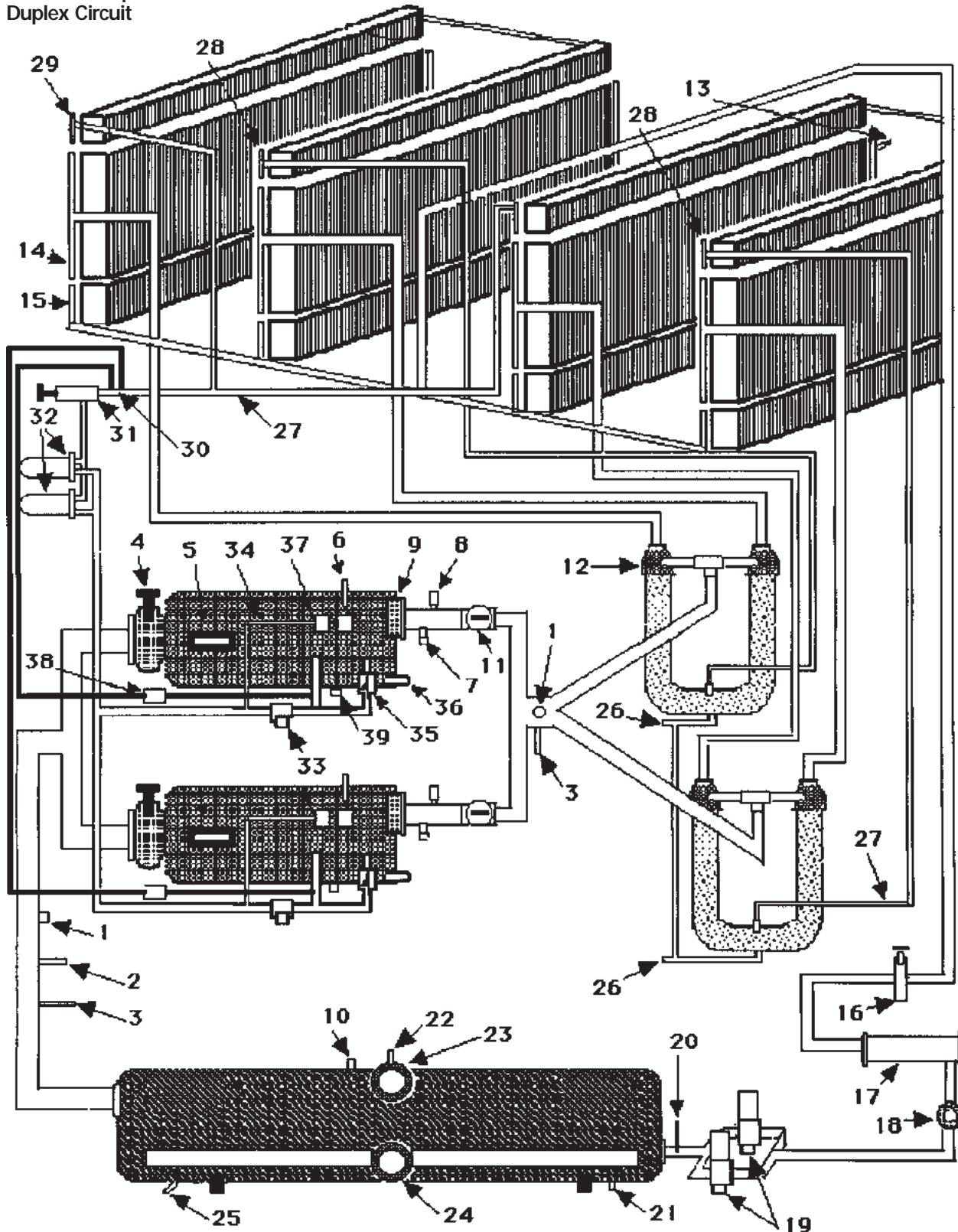

Figure 41
(Continued from Previous Page)

REFRIGERATION SYSTEM AND CONTROL COMPONENTS

- | | | |
|---|---|---|
| 1 Schrader valve | 17 25 micron filter/drier | 33 Master solenoid valve* |
| 2 Suction temperature sensor* | 18 Liquid line sight glass | 34 Oil line to load/unload slide valve solenoids |
| 3 Manufacturing process tube | 19 Electronic expansion valve* | 35 Injection oil check valve |
| 4 Suction service valve (optional) | 20 Saturated evaporator temperature sensor* | 36 Heater |
| 5 Motor winding thermostat* | 21 Evaporator waterside drain | 37 Slide valve solenoids and orifices* |
| 6 Discharge temperature sensor | 22 Leaving water temperature sensor* | 38 Oil flow differential pressure switch* |
| 7 Pressure relief valve (450 psi) | 23 Leaving water connection | 39 Compressor Drain Plug |
| 8 High pressure cutout (405 psi)* | 24 Entering water connection | 40 Domestic water heater (optional) |
| 9 Discharge check valve | 25 Entering water temperature sensor* | 41 Oil line thermostat (option, Domestic Water Heater) |
| 10 Evaporator waterside vent | 26 Drain with Schrader valve | 42 Oil line bypass solenoid valve (option, Domestic Water Heater) |
| 11 Discharge line shutoff valve | 27 Oil line | |
| 12 Oil separator in/out cap | 28 Entering oil, cooler header | |
| 13 Saturated condensing temperature sensor* | 29 Leaving oil cooler header | |
| 14 Condenser header | 30 Schrader valve with stem depressor | |
| 15 Subcooler header | 31 Oil line shutoff valve | |
| 16 Liquid line shutoff valve | 32 5 micron oil filter | |

*UCM Input/Output Control

Figure 42
Typical RTAA Compressor

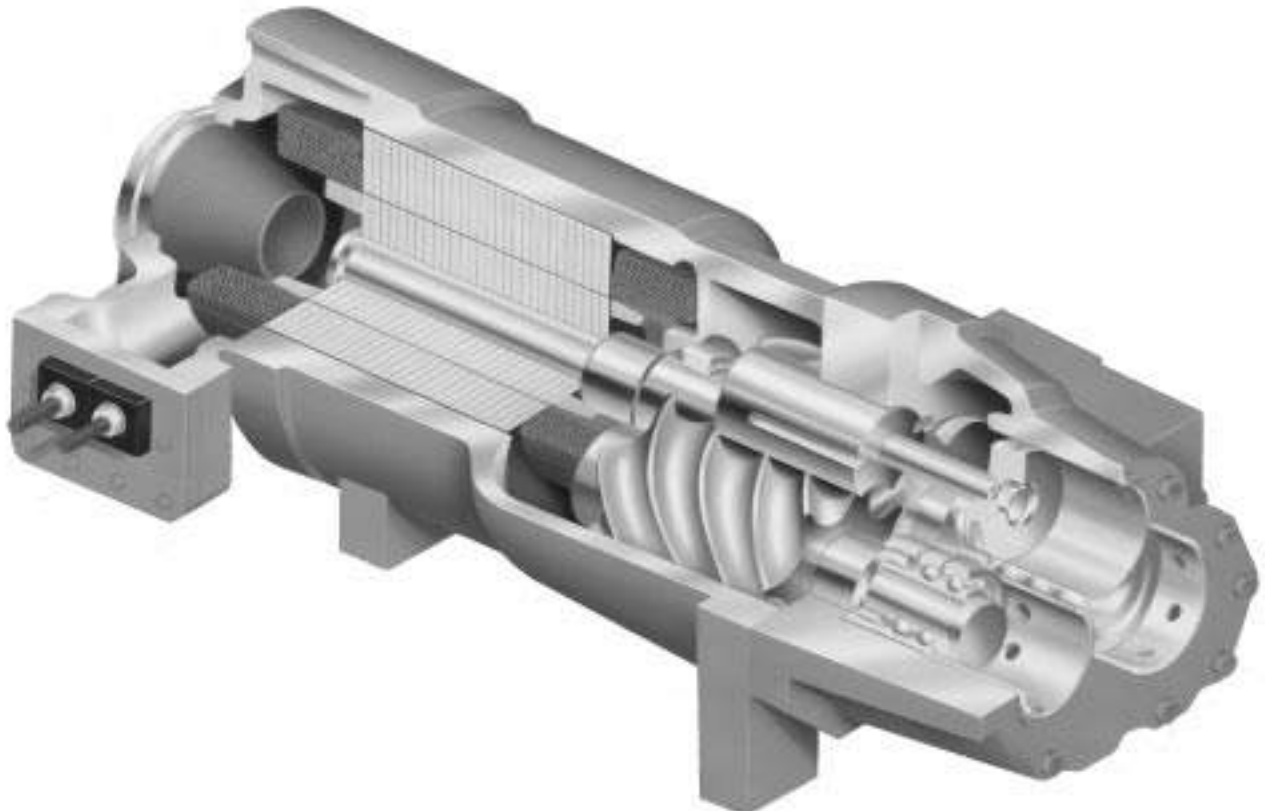

Oil System Operation

Overview

Oil that collects in the bottom of the oil separator is at condensing pressure during compressor operation; therefore, oil is constantly moving to lower pressure areas. Refer to Figure 43.

As the oil leaves the separator, it passes through the air-cooled oil cooler at the top of the condensing coils. It then goes through the service valve and filter. At this point, some of the oil is used to control the slide valve movement in the compressor, via the load/unload solenoids. The remaining oil passes through the oil master solenoid valve and performs the functions of compressor bearing lubrication and compressor oil injection. If the compressor stops for any reason, the master solenoid valve closes, isolating the oil charge in the separator and oil cooler during "off" periods.

To ensure proper lubrication and minimize refrigerant condensation in the compressor, a heater is mounted on the bottom of the compressor housing. A signal from the UCM energizes this heater during the compressor "Off" cycle to keep refrigerant from condensing in the compressor. The heater element is continuously energized.

Domestic Water Heater

The Domestic Water Heater option utilizes available waste heat from the compressor oil circuit, to heat domestic or process water. Normally, the excess heat is dissipated to the atmosphere by fans moving air over the oil cooler.

The high temperature oil that leaves the oil separator enters the domestic water heater. Heat is transferred from the oil to the cool water that enters the heater. The oil then passes either through the unit's air-cooled oil cooler, where additional heat is removed, if required, or through the air-cooled oil cooler bypass solenoid, that is operated by a thermostat on the oil supply line.

Water that is heated in the domestic water heater exits the heater and flows to the system.

Figure 43
RTAA Compressor Oil System
Schematic

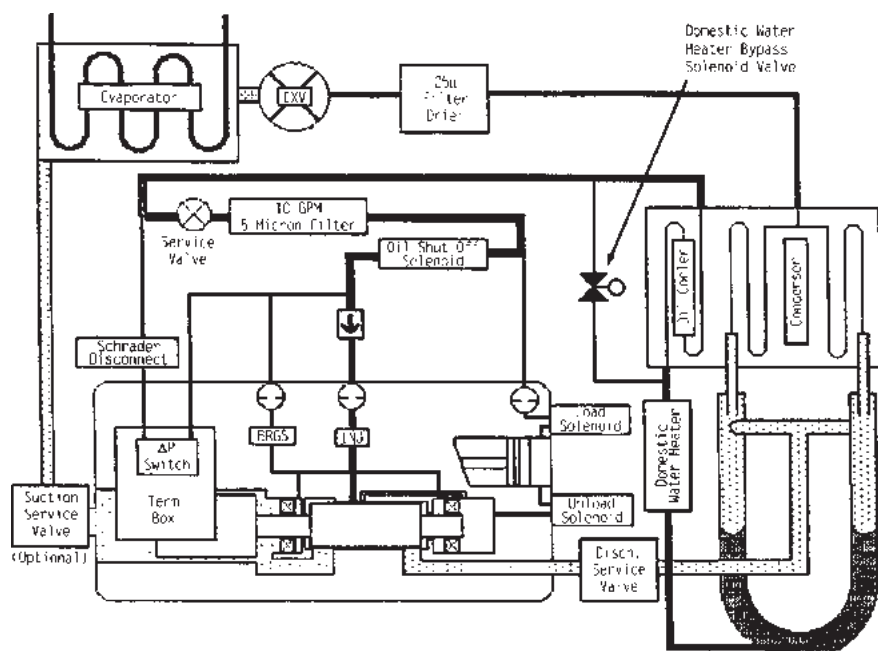

Oil Separator

The oil separator consists of a U-shaped tube, joined at the top by the refrigerant discharge line from the compressor. As shown in Figure 44, the discharge line is essentially tangential to the U-tubes. This causes the refrigerant to swirl in the tubes and throws the oil to the outside, where it collects on the walls and flows to the bottom. The compressed refrigerant vapor, stripped of oil droplets, exits out the top of the oil separator and is discharged into the condensing coils.

Compressor Bearing Oil Supply

Oil is injected into the bearing housings located at each end of both the male and female rotors. Each bearing housing is vented to compressor suction, so that oil leaving the bearings returns through the compressor rotors to the oil separator.

Compressor Rotor Oil Supply

Oil flows through this circuit directly from the master solenoid valve through the oil filter to the top of the compressor rotor housing. There it is injected along the top of the rotors to seal clearance spaces between the rotors and the compressor housing and to lubricate the rotors.

Figure 44
Oil Separator

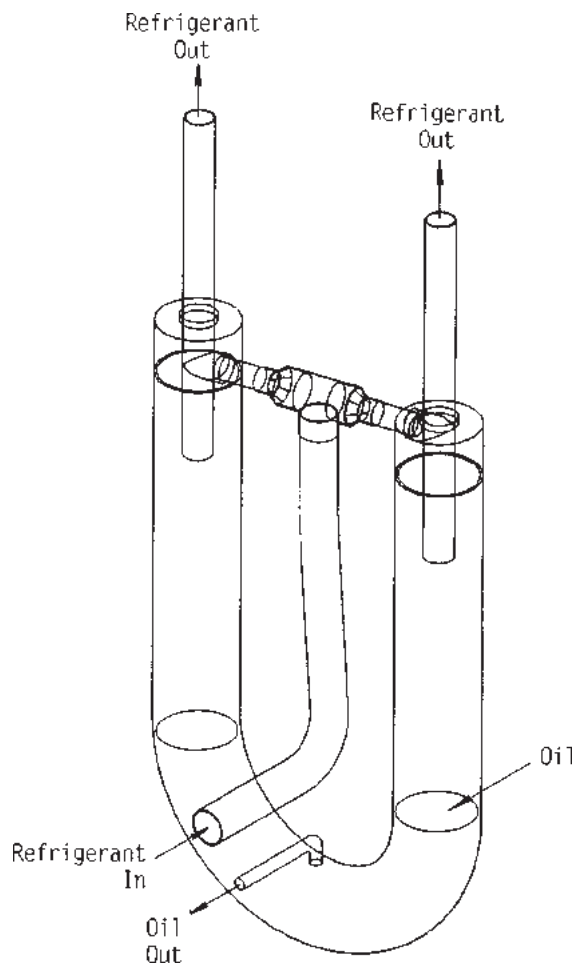

Slide Valve Movement

Movement of the slide valve piston determines slide valve position which, in turn, regulates compressor capacity. Oil flow into and out of the cylinder governs piston movement, and is controlled by the normally-closed, load and unload solenoid valves.

The solenoid valves receive momentary pulsating “load” and “Unload” voltage signals from the UCM based on system cooling requirements. To load the compressor, the UCM opens the load solenoid valve while keeping the unload solenoid valve closed. The pressurized oil flow then enters the cylinder and forces the slide valve to move over the rotors.

The compressor is unloaded when the load solenoid valve is kept closed and the unload solenoid valve is opened. Oil “trapped” within the cylinder is drawn out into the lower-pressure suction area of the compressor. As the pressurized oil leaves the cylinder, the slide valve gradually moves away from the rotors.

When both solenoid valves are closed, the present level of compressor loading is maintained.

Just prior to a normal compressor shutdown, the unload solenoid valve is energized and the slide valve moves to the fully-unloaded position, so the unit always starts fully unloaded.

Oil Filter

Each refrigerant circuit is equipped with replaceable-element oil filters. The filter(s) remove any impurities that could foul the solenoid valve orifices and compressor internal oil supply galleries. This also prevents excessive wear of compressor rotor and bearing surfaces. Refer to the maintenance portion of this manual for recommended filter element replacement intervals.

Condenser Fans

The RTAA Series offers either the 15 F or 0 F ambient fan configuration. On the 0 F ambient option, the lead fan(s) on each circuit is a half-airflow (half-pitch blade) fan(s). Half pitch fans have a blade pitch of 150 and full pitch fans have a blade pitch of 27°.

Figures 45 and 46 show the number of fans installed on each model, the designation of fan contactors and the staging of fans as the UCM calls for more condenser cooling. Fan staging is a function of the difference between the saturated condenser refrigerant temperature and the saturated evaporator refrigerant temperature, which in turn is a function of the load and ambient temperature. Any number of fans can be operating at a given time, depending on these variables.

Figure 45
Fan Configurations – RTAA 130-200 Tons
15 F Minimum Ambient

All fans will be Full Airflow (Full Pitch Blade) Fans:
 Circuit #1 is on the right side of the unit from the control panel.
 Circuit #2 is on the left side of the unit from the control panel.

Tons	# Of Fans Circuit #1	# Of Fans Circuit #2	UCM Outputs Per Circuit	# Fan Steps/Circuit
130	5	5	4	5 & 5 respectively
140	5	5	4	5 & 5 respectively
155	6	5	4	6 & 5 respectively
170	7	5	4	7 & 5 respectively
185	7	6	4	7 & 6 respectively
200	7	7	4	7 & 7 respectively

For STANDARD air-cooled (RTAA) Chillers, the mapping of UCM outputs to fan staging shall be as follows:

Fan Contactor	5 Fan Circuit				6 Fan Circuit				7 Fan Circuit			
Circuit #1	K9	K10	K11	K12	K9	K10	K11	K12	K9	K10	K11	K12
Circuit #2	K13	K14	K15	K16	K13	K14	K15	K16	K13	K14	K15	K16
Number of Fan(s)/ Contactor	1	1	1	2	1	1	2	2	1	1	2	3
Fan Steps												
0	-	-	-	-	-	-	-	-	-	-	-	-
1	x	-	-	-	x	-	-	-	x	-	-	-
2	x	x	-	-	x	x	-	-	x	x	-	-
3	x	x	x	-	x	-	x	-	x	-	x	-
4	x	x	-	x	x	x	x	-	x	x	-	x
5	x	x	x	x	x	-	x	x	x	x	-	x
6	-	-	-	-	x	x	x	x	x	-	x	x
7	-	-	-	-	-	-	-	-	x	x	x	x

X = ON

Figure 46
Fan Configurations - RTAA 130-400 Tons - 0 F Minimum Ambient

The 0 F AMBIENT OPTION will have Half Airflow (Half Pitch Blade) Fan.

Tons	# Of Fans Circuit #1	# Of Fans Circuit #2	UCM Outputs Per Circuit	Fan Steps/Circuit
130	5*	6*	4	9 & 10 respectively
140	5*	6*	4	9 & 10 respectively
155	6*	6*	4	10 & 10 respectively
170	7*	6*	4	11 & 10 respectively
185	7*	7*	4	11 & 11 respectively
200	7*	7*	4	11 & 11 respectively
215	7*	7*	4	11 & 11 respectively
240	10**	7*	4	9 & 11 respectively
270	12**	7*	4	10 & 11 respectively
300	14**	7*	4	11 & 11 respectively
340	10**	14**	4	9 & 11 respectively
370	12**	14**	4	10 & 11 respectively
400	14**	14**	4	11 & 11 respectively

*The first fan on each single compressor circuit is a Half Airflow (Half Pitch Blade) Fan.
 **The first two fans on each dual compressor circuit are Half Airflow (Half Pitch Blade) Fans.

For 0 F AMBIENT OPTION air-cooled (RTAA) Chillers, the mapping of UCM outputs to fan staging shall be as follows:

Fan Contactor	5 & 10 Fan Circuit				6 & 12 Fan Circuit				7 & 14 Fan Circuit			
Circuit #1	K9	K10	K11	K12	K9	K10	K11	K12	K9	K10	K11	K12
Circuit #2	K13	K14	K15	K16	K13	K14	K15	K16	K13	K14	K15	K16
Number of Fans/Contactor												
Single Comp. Ckt.	1*	1	1	2	1*	1	2	2	1*	1	2	3
Dual Comp. Ckt. 2*	2	2	4	2*	2	4	4	2*	2*	2	4	6

* = Half AirFlow Fan

Fan Steps													
Single Compr Ckt	Dual Compr Ckt												
0.0	0.0	-	-	-	-	-	-	-	-	-	-	-	-
0.5	1	x	-	-	-	x	-	-	-	x	-	-	-
1	2	-	x	-	-	-	x	-	-	-	x	-	-
1.5	3	x	x	-	-	x	x	-	-	x	x	-	-
2	4	-	x	x	-	-	-	x	-	-	-	x	-
2.5	5	x	x	x	-	x	-	x	-	x	-	x	-
3	6	-	x	-	x	-	x	x	-	-	-	-	x
3.5	7	x	x	-	x	x	x	x	-	x	-	-	x
4	8	-	x	x	x	-	-	x	x	-	x	-	x
4.5	9	x	x	x	x	x	-	x	x	x	x	-	x
5.5	11	-	-	-	-	x	x	x	x	x	-	x	x
6.5	13	-	-	-	-	-	-	-	-	x	x	x	x

X = ON

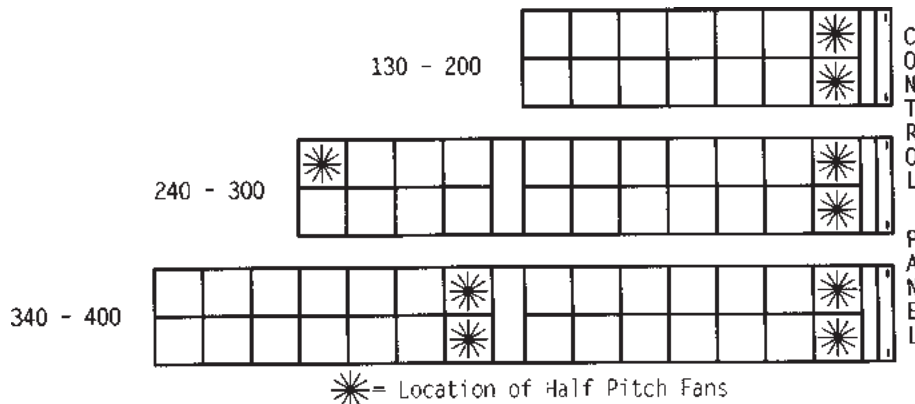

Operating Principles – Adaptive Control™ Microprocessor Logic

General

The exclusive Trane Adaptive Control logic is comprised of a system of individual modules called the Unit Control Module (UCM), located in the Control Panel. The system consists of four types of microprocessor-based components and the operator interface, as shown in Figures 47 thru 51. The processors are:

Chiller Module (Base or Deluxe) - 1U1
Communication and Setpoint Reset Option Module - 1U2
Expansion Valve Module - 1U3
Compressor Module (one per compressor) - 1U4, 1U5, 1U6, 1U7
Slave Expansion Valve Module (240 -400 ton units) - 1U8

The Adaptive Control Chiller Module is available in two versions, a base model and a deluxe model. The deluxe model offers the additional features of:

1. Under/Over Voltage Protection (Includes U/O voltage sense transformer).
2. Display of Compressor Starts and Hours
3. Display of % Line Volts
4. Alarm/Running/Max Capacity Contacts

Local operator interface with the system is accomplished using the four display buttons on the LICK Data readouts are shown on the seven-digit, digital display. The three-position switch is used to set chiller operation.

Digital Display

The digital display shows:

- both operating and diagnostic codes
- compressor status indicators
- settings of a local setpoints and adjustments
- actual controlling setpoints
- specified temperatures
- specified pressures
- enable/disable status of features and options
- selection status of SI units or English units for display of temperatures and pressures

All display segments and any used decimal points will be briefly turned on to provide a visual test of their operation, following a Power-On-Reset. The chiller operating codes (“A” prefix) will then be displayed. The data to be shown on the digital display is selected by using the Display Up and Display Down keys. Changing of the display and menus is discussed below.

The digital display will light an indicator at the bottom of the display, above the “A”, “B”, “C” or “D” and circuit 1 or circuit 2. In Menu 0, these indicators show which compressor/circuit is running. In Menu 2, these indicators show which compressor/circuit is related to the displayed parameter.

A “Circuit Lockout” indicator will be lit if either circuit is enabled (E) in Menu 1 A (Circuit Lockout) or either circuit is “OFF” on its external Circuit Lockout contacts and Menu 3B, (External Circuit Lockout) is enabled (E).

Figure 47
RTAA Control Panel –
130 to 200 Tons

LEGEND:

Device Designation	Description
1F1-6	Fan Fuses, Circuit 1
1F7-12	Fan Fuses, Circuit 2
1F15	Control Circuit Fuse
1F16, 1F17	Control Power Transformer Fuses
1K1, 1K5	Start Contactors
1K2, 1K6	Run Contactors
1K4, 1K8	Transition Contactors
1K3, 1K7	Shorting Contactors
1K9-12	Fan Contactors, Circuit 1
1K13-16	Fan Contactors, Circuit 2
1S1, 1S2	Non-fused Disconnect Switch
1T1	Control Power Transformer
1T2	Under/Over Voltage Transformer
1T3-5	Compressor Current Transformer, Circuit 1
1T6-8	Compressor Current Transformer, Circuit 2
1TB1,1TB2	Line Voltage Terminal Blocks
1TB3	Terminal Strip, 115 V
1U1	Chiller Module
1U2	Options Module
1U3	Expansion Valve Module
1U4	Compressor Protection Module, Compressor A
1U5	Compressor Protection Module, Compressor B

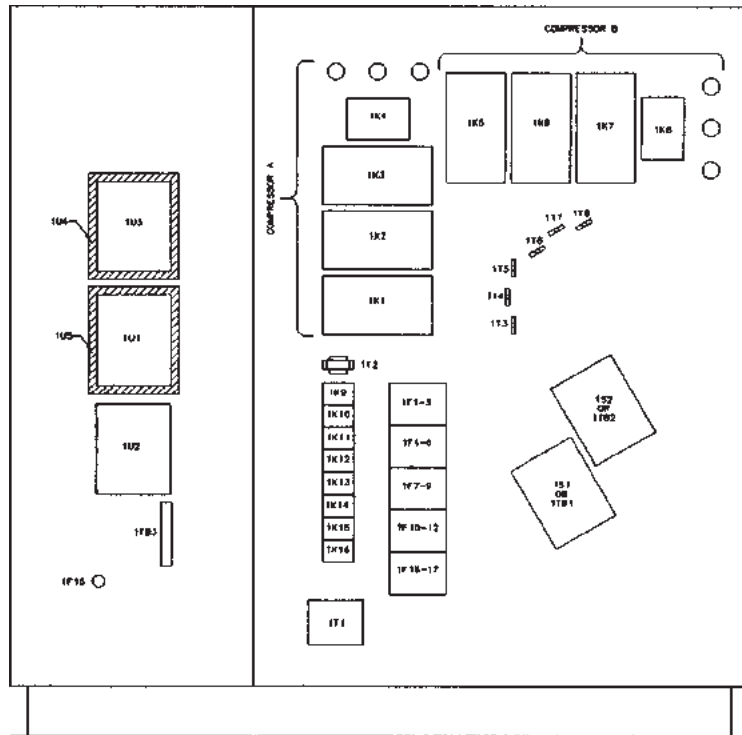

CONTROL PANEL

POWER PANEL Y-DELTA START

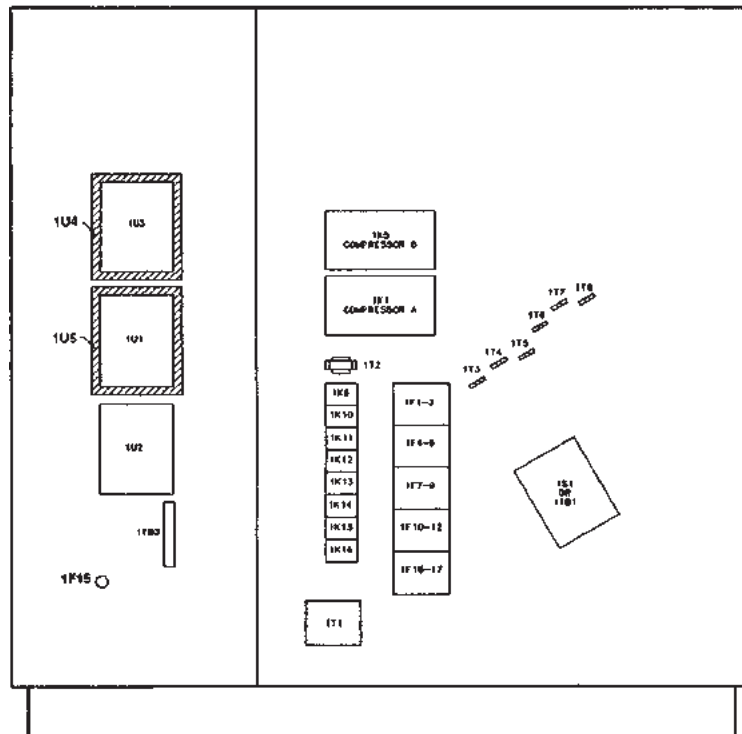

CONTROL PANEL

POWER PANEL X-LINE START

Figure 48
RTAA Control Panel –
240 to 300 Tons

LEGEND:

Device Designation	Description
1F1-6	Fan Fuses, Circuit 1
1F7-12	Fan Fuses, Circuit 2
1F15	Control Circuit Fuse
1F16, 1F17	Primary Transformer Fuses
1K1, 1K2	Start Contactors, Circuit 1
1K3, 1K4	Start Contactors, Circuit 2
1K9-12	Fan Contactors, Circuit 1
1K13-16	Fan Contactors, Circuit 2
1S1, 1S2	Non-fused Disconnect Switch
1T1	Control Power Transformer
1T2	Under/Over Voltage Transformer
1T3-8	Compressor Current Transformer, Circuit 1
1T9-14	Compressor Current Transformer, Circuit 2
1TB1, 1TB2	Line Voltage Terminal Blocks
1TB3, 1TB4	Terminal Strip, 115 V
1U1	Chiller Module
1U2	Options Module
1U3	Expansion Valve Module
1U4	Compressor Protection Module, Compressor A
1U5	Compressor Protection Module, Compressor B
1U6	Compressor Protection Module, Compressor C
1U8	Slave Expansion Valve Module

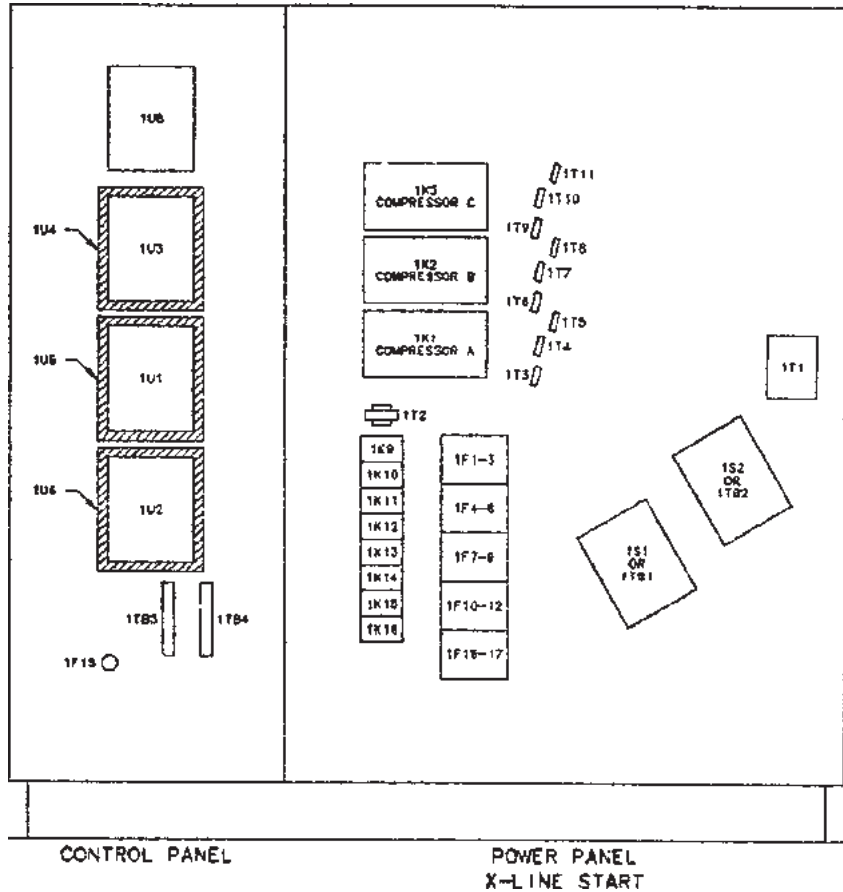

Figure 49
RTAA Control Panel –
340 to 400 Tons

LEGEND:

Device Designation	Description
1F1-6	Fan Fuses, Circuit 1
1F7-12	Fan Fuses, Circuit 2
1F15	Control Circuit Fuse
1F16, 1F17	Primary Transformer Fuses
1K1, 1K2	Start Contactors, Circuit 1
1K3, 1K4	Start Contactors, Circuit 2
1K9-12	Fan Contactors, Circuit 1
1K13-16	Fan Contactors, Circuit 2
1S1, 1S2	Non-fused Disconnect Switch
1T1	Control Power Transformer
1T2	Under/Over Voltage Transformer
1T3-8	Compressor Current Transformer, Circuit 1
1T9-14	Compressor Current Transformer, Circuit 2
1TB1,1TB2	Line Voltage Terminal Blocks
1TB3,1TB4	Terminal Strip, 115 V
1U1	Chiller Module
1U2	Options Module
1U3	Expansion Valve Module
1U4	Compressor Protection Module, Compressor A
1U5	Compressor Protection Module, Compressor B
1U6	Compressor Protection Module, Compressor C
1U7	Compressor Protection Module, Compressor D
1U8	Slave Expansion Valve Module

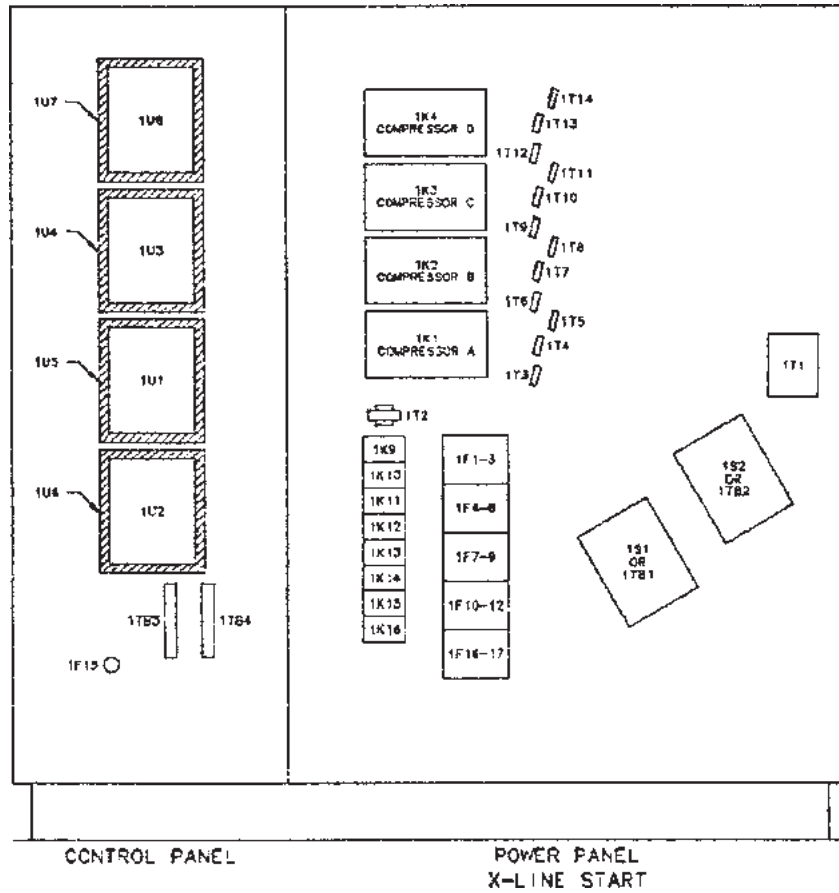

Figure 50
RTAA Control Panel –
130 to 200 Tons
with Remote Evaporator Option

LEGEND:

Device Designation	Description
1F1-6	Fan Fuses, Circuit 1
1F7-12	Fan Fuses, Circuit 2
1F15	Control Circuit Fuse
1F16, 1F17	Primary Transformer Fuses
1K1, 1K5	Start Contactors
1K2, 1K6	Run Contactors
1K4, 1K8	Transition Contactors
1K5, 1K7	Shorting Contactors
1K9-12	Fan Contactors, Circuit 1
1K13-16	Fan Contactors, Circuit 2
1S1, 1S2	Non-fused Disconnect Switch
1T1	Control Power Transformer
1T2	Under/Over Voltage Transformer
1T3-5	Compressor Current Transformer, Circuit 1
1T6-8	Compressor Current Transformer, Circuit 2
1TB1, 1TB2	Line Voltage Terminal Blocks
1TB3	Terminal Strip, 115 V
1TB8, 1TB9	Terminal Strip, 24 V
1U1	Chiller Module
1U2	Options Module
1U3	Expansion Valve Module
1U4	Compressor Protection Module, Compressor A
1U5	Compressor Protection Module, Compressor B

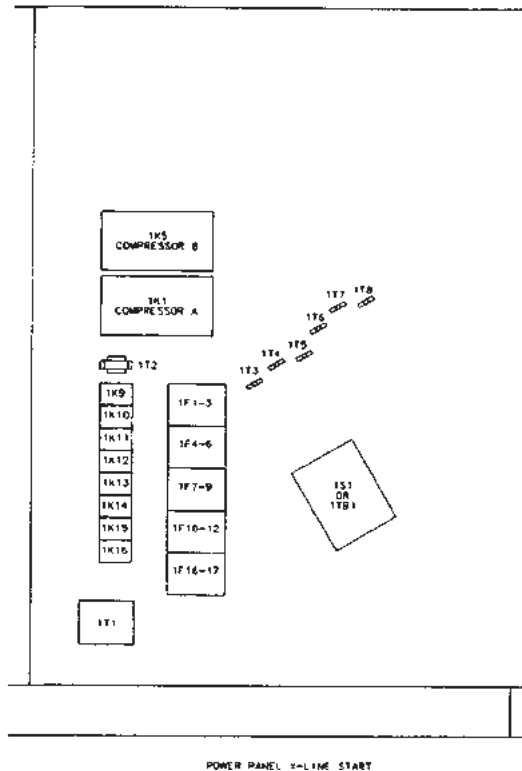
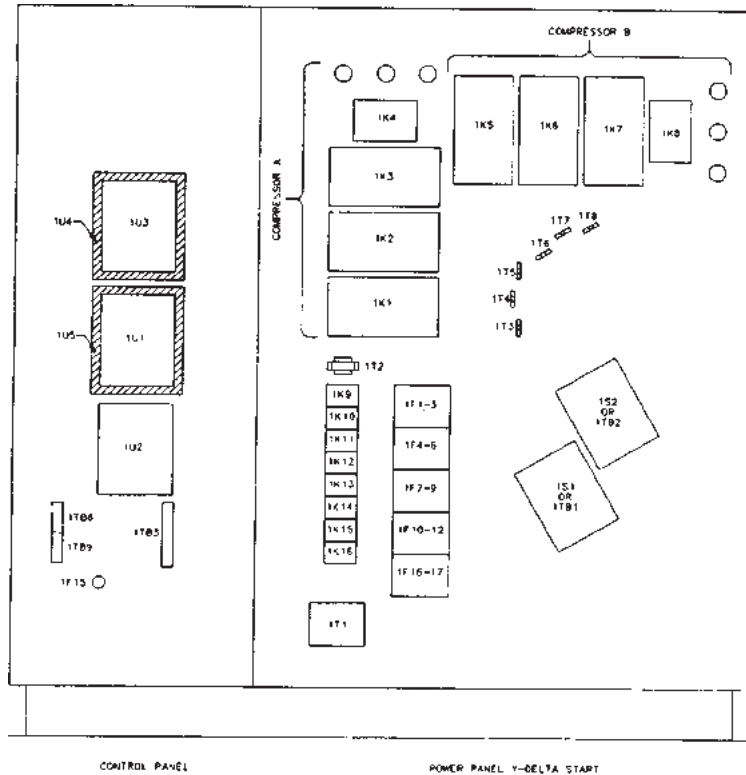
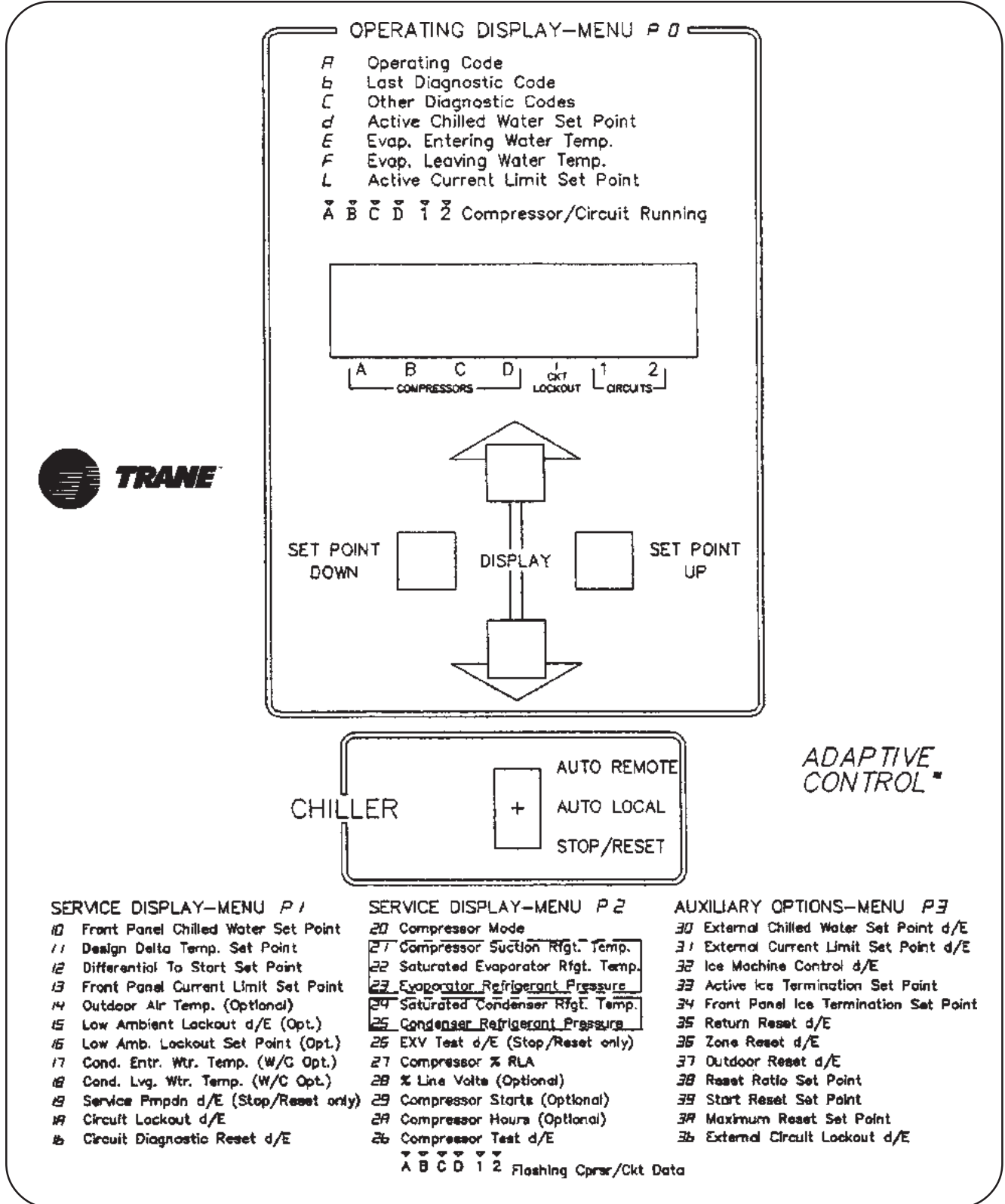

Figure 51
Operator Interface Controls



Menus

There are six menus, four of which are shown on the operator interface panel and two factory displays, which are described later in this section. The menus are numbered as follows:

Operating Display - Menu 0
Service #1 Display - Menu 1
Service #2 Display - Menu 2
Auxiliary Options Display - Menu 3
Factory Display - Menu 4
Factory Display - Menu 5

Each menu can be considered to be a page of data, formatted as shown in Figure 52. The operator can view one line of the menu at a time (menu item) on the digital display and can scroll through the menu by using the Display Up and Display Down keys. For example, when the digital display shows "P 0", the UCM is in the "Operating Display" menu. By depressing the Display Down key one time, the next line of the menu, "Operating Code", will be shown as an "A", along with the current unit operating status. All operating and diagnostic codes are described on the "Condition Codes" label, as shown in Figure 53.

There are a few exceptions to the scrolling function. When a menu selection represents multiple pieces of information:

"C" Menu Item - Other Diagnostic Codes": When this menu item is selected, depressing the Display Down key will display diagnostic history in code number sequence. Use the Display Up key to return to the top of the list. While in the "C" menu item, flashing indicates that the information is currently "true", whereas steady, or non-flashing indicates historic data only. The digital display will not advance to the next item (d) until all diagnostics have been displayed. If there are no diagnostics to display, the data field will be blank for one key stroke.

Compressor/Circuit Parameters: Because the unit has two, three or four compressors and two refrigerant circuits, items that refer to compressors or circuits will remain selected until information for all have been displayed. For example, assume a "29", "Compressor Starts", menu selection on a two compressor unit. The menu numbered "29" will be displayed and the indicator over the "A" compressor will be flashing. By depressing the Display Down key one time, the "29" will remain but the indicator light over the "B" compressor will be flashing. Another Display Down

key stroke will display menu "2A", Compressor Hours, with compressor "A" indicator flashing. If either the Display Up or Display down keys are held down, the scrolling will continue until the key is released, or until reaching the top or bottom of the menu. In this case, the display will return to the "P" menu position and stop.

To change menus, scroll to the "P" menu position and use the Set Point Up or Set Point Down keys. For example, assume that the display shows "P 0" and it is desired to view the Auxiliary Options on Menu 3. Depress the Set Point Up key three times and the "P 3" menu will be displayed. To return to Menu 0, depress the Set Point Down key three times or Set Point Up key once (to wrap around) and "P 0" will be displayed. This procedure will work for menus 0 through 3.

A combination of key strokes is required to access menus 4 and 5. With the display in the "P" menu position (P), use the Set Point Up and Down keys to display "0, 1, 2, 1, 2, 3, 2, 3, 4". Once in the "P 4" menu, use the Set Point Up key to access menu 5.

All menus are always accessible, whether the unit is in a "running" or "stopped" mode.

Figure 52 Menu Formats

OPERATING DISPLAY - MENU 0

Selected by setting the number 0 in the "P" menu item. Compressor/circuit indicators will be lit continuously in this menu to indicate which compressors/circuits are running. All items of Menu 0 are display only. Setpoint changes must be made in other menus.

Display Code and Description

P	Menu Number
A	Operating Code
b	Last Diagnostic Code
C	Other Diagnostic Codes
d	Active Chilled Water Setpoint*
E	Evaporator Entering Water Temperature
F	Evaporator Leaving Water Temperature
L	Active Current Limit Setpoint

*Dashes are displayed for the setpoint when the chiller is either in the "Ice Building" or "Ice Building Complete" mode.

Figure 52
Menu Formats (Continued)

SERVICE #1 DISPLAY – MENU 1

Selected by setting the number 1 in the “P” menu item. The compressor circuit indicators will not be lit continuously in this menu to indicate which compressors are running. As the menu is advanced, the appropriate compressor/circuit indicator will flash.

Display Code and Description	UCM Based Defaults	Setpoint Range
P Menu Number		
10 Front Panel Chilled Water Setpoint	44 F	0 to 65 F
11 Design Delta Temperature Setpoint	10 F	4 to 30 F
12 Differential to Start Setpoint	2 F	2 to 30 F
13 Front Panel Current Limit Setpoint	120%	40 to 120%
14 Outdoor Air Temperature (Optional)		
15 Low Ambient Lockout - d/E (Optional)	d	
16 Low Ambient Lockout Setpoint - d/E (Optional)*	20 F	-20 to 40 F
17 Cond. Entering Water Temperature (Optional) RTAA Non Applicable		
18 Cond. Leaving Water Temperature (Optional) RTAA = Non Applicable		
19 Service Pumpdown d/E (Stop/Reset only)**	d	
1A Circuit Lockout d/E**	d	
1b Circuit Diagnostics Reset**	d	

*Dashes are displayed for the setpoint when the Low Ambient Lockout (15) is disabled.

**Displayed by Compressor/Circuit

SERVICE #2 DISPLAY - MENU 2

Selected by setting the number 2 in the “P” menu item. Compressor/Circuit indicators shall not be lit continuously in this menu to indicate which compressors are running. As the menu is advanced, the appropriate compressor/circuit indicator will flash.

Display Code and Description	UCM Based Defaults	Setpoint Range
P Menu Number		
20 Compressor Mode*		
21 Compressor Suction Refrigerant Temp.*		
22 Compressor Evap. Refrigerant Temp.*		
23 Evaporator Refrigerant Pressure*		
24 Saturated Condenser Refrigerant Temp.*		
25 Condenser Refrigerant Pressure*		
26 EXV Test - d/E (Only in STOP/RESET)*	d	
27 Compressor % RLA (Highest leg)*		
28 % Line Volts (Optional)		
29 Compressor Starts (Optional)*		
2A Compressor Hours (Optional)*		
2b Compressor Test d/E	d	

*Displayed by compressor/circuit

Compressor Starts, Compressor Hours and % Line Volts will be displayed as dashes (e.g. “2A when this option is not installed.

After the EXV test has been completed, the “E” will be automatically reset to “d”.

See “Electronic Expansion Valve (EXV) Test”.

The Condenser Refrigerant Pressure and the Evaporator Refrigerant Pressure, displayed on the UCM, are the saturated condenser and evaporator temperatures converted to R-22 pressure readings. The units are PSIG (Kilopascal gauge) and referenced to an elevation of sea level or 14.6960 psia (101.3289 KPa absolute).

Figure 52
Menu Formats (Continued)

AUXILIARY OPTIONS – MENU 3

Selected by setting the number 3 in the “P” menu number position. Compressor/circuit indicators will not be lit continuously in this menu to indicate which compressors/circuits are running.

Display Code and Description		UCM Based Defaults	Setpoint Range
P	Menu Number		
30	External Chilled Water Setpoint - d/E	d	
31	External Current Limit Setpoint - d/E	d	
32	Ice Machine Control - d/E	d	
33	Active-Ice Termination Setpoint*		
34	Front Panel Ice Termination Setpoint	27 F	20 to 31 F
35	Return Reset - d/E**	d	
36	Zone Reset - d/E**	d	
37	Outdoor Reset - d/E**	d	
38	Reset Ratio Setpoint***		
	Return	50%	10 to 120%
	Zone	100%	50 to 300%
	Outdoor	10%	-80 to 80%
39	Start Reset Setpoint***		
	Return	10 F	4 to 30 F
	Zone	78 F	55 to 85 F
	Outdoor	90 F	50 to 130 F
3A	Maximum Reset Setpoint***		
	Return	5 F	0 to 20 F
	Zone	5 F	0 to 20 F
	Outdoor	5 F	0 to 20 F
3b	External Circuit Lockout d/E	d	

*Dashes are displayed for the setpoint when the chiller is not in the “Ice Building” or “Ice Building Complete” mode.

**The UCM will permit only one type of reset (Return, Zone, or Outdoor) to be selected at one time. For example, if Return Reset is enabled, an attempt to enable Zone Reset would disable RETURN RESET and enable Zone Reset automatically.

***The UCM contains setpoints for each of the types of reset. The setpoint displayed will be for the type of reset enabled. If no reset is enabled, dashes will be displayed.

Figure 52
Menu Formats (Continued)

FACTORY DISPLAY #1 - MENU 4

Caution: Do not leave unit unattended while in Menu 4 or 5. Inadvertent unit safety setpoint changes could occur.

Selected by setting the number 4 in the "P" menu item. Unlike menus 0 through 3, the number 4 can only be set by entering a combination of numbers. This combination consists of a sequence of "P" menu numbers -0, 1, 2, 1, 2, 3, 2, 3, 4.

Compressor/circuit indicators will not be lit continuously in this menu to indicate which compressors are running. As the menu is advanced the appropriate compressor/circuit indicator will flash.

Display Code and Description	UCM Based Defaults	Setpoint Range
P Menu Number		
40 Leaving water Temp. Cutout Setpoint	35 F	-10 to 35 F
41 Low Refrigerant Temp. Cutout Setpoint	22 F	-39 to 35 F
42 Condenser Limit Setpoint - % HPC	90%	80 to 120%
43 Lead/Lag - d/E	E	
44 SI Display Units - d/E	d	
45 Unit Line Voltage*	460 V	
46 Under/Over Voltage Protection - d/E	d	
47 Phase Imbalance Protection d/E	E	
48 Phase Reversal Protection d/E	E	
49 Superheat Setpoint	8 F	4 to 20 F
4A EXV Control Response Setpoint**	20	2 to 200
4b LWT Control Response Setpoint	40	2 to 220
4C ICS Address (Optional)		
4d Fan Control Deadband Bias**	0	-50 to +50
4E Programmable Relay Setup (see Alarm/Running/Maximum Capacity Contact Outputs)	1	1 to 12
4F Restart Inhibit Timer	120 sec.	30 to 120 sec.

*Entry will be selected from 200, 220, 230, 346, 380, 415, 460, 500 or 575 volts. Dashes will be displayed if the Under/Over Voltage Protection option is not installed.

**Displayed by circuit.

Figure 52
Menu Formats (Continued)

FACTORY DISPLAY #2 - MENU 5

Caution: Do not leave unit unattended while in Menu 4 or 5. Inadvertent unit safety setpoint changes could occur.

Selected by setting the number 5 in the "P" menu item. Unlike menus 0 through 3, the number 5 can only be set after menu 4 has been selected, as described on the previous page.

Compressor/circuit indicators will not be lit continuously in this menu to indicate which compressors are running. As the menu is advanced the appropriate compressor/circuit indicator will flash.

<u>Display Code and Description</u>	<u>UCM Based Defaults</u>	<u>Setpoint Range</u>
P Menu Number		
50 Number of Compressors	1	1, 2, 3, 4
51 Compressor Tons*	100	25, 30, 40,50, 60, 70, 85, 100
52 Low Water Temp EXV Gain Compensation d/e	d	
53 Fan Control - d/E	E	
54 Fans per Circuit**	7	4, 5, 6,7, 8, 10, 12, 14
55 Reduced Inrush Starting - d/E	d	
56 Compressor Current Overload Setting (to match DIP Switch)*	00	00 to 31
57 GP Compressor Unit d/E	d	
58 Low Ambient - Half Air Flow Fan d/E	d	
59 LATSM d/E	d	
5A NNS d/E	d	
5b Number of EXV Valves per Circuit**	1	1, 2
5c Future Option**	d	

*Displayed by compressor.

**Displayed by circuit

Figure 53
Condition/Diagnostic Codes

Condition Codes

UNIT OPERATING STATUS

CODE	DESCRIPTION
Blank	UCM Power Off
888888.8	UCM Paw Up
00	Unit Stop
01	Auto-Local
02	Auto-Remote
17	Service Pumpdown
70	Unit Restart Inhibit
72	Unit Start
74	Run:Normal
75	Run:Current Limit
78	Run:Condenser Limit
77	Run:Evaporator Limit
7E	Run:Unload
88	Reset
100	External Unit Stop
101	Ice Building Complete
118	EXV Test
174	Ice Building: Normal
175	Ice Building: Current Limit
176	Ice Building: Condenser Limit
177	Ice Building: Evaporator Limit
200	Low Ambient Run Inhibit

COMPRESSOR OPERATING STATUS

CODE	DESCRIPTION
00	Compressor Stop
16	Compressor Lockout
17	Cprsr Service Pumpdown
70	Cprsr Restart Inhibit
72	Cprsr Start
74	Run Normal
75	Run: Current Limit
76	Run: Condenser Limit
77	Run: Evaporator Limit
7E	Run:Unload

DIAGNOSTIC TYPES

MMR	Machine Shutdown-Manual Reset
CMR	Circuit Shutdown-Man Reset
MAR	Machine Shutdown-Auto Reset
CAR	Circuit Shutdown-Auto Reset
IFW	Informational-Warning

UNIT DIAGNOSTICS CONDITION

FLASHING DISPLAY:

A xxx
A xxx ↔ C yyy
b yyy
C yyy
10 uu

MEANS:

A New CMR, CAR, or IFW Diagnostic Exists.
Operating Code when MMR or MAR occurred. Diagnostic currently inhibiting operation.
Manual reset required to restore full operation. This or other latching diagnostics exist.
Condition creating MAR, CAR or IFW still exists. If MMR or CMR, manual reset required.
The chilled water setpoint is too close to a cutout setpoint.

DASHES:

d ----
33 ----
Other (e.g. 14----)

MEANS:

The chiller is in either ice bldg or ice bldg compl; lvg chld wtr stpt is not applicable.
The chiller is in normal cooling; the active ice termination setpoint is not applicable.
Option either not installed or not enabled.

CODE	DESCRIPTION	TYPE	CODE	DESCRIPTION	TYPE
87	Chock External Chilled Water Stpt	IFW	19F	Phase Loss - Cprsr D	CMR
89	Check External Current Limit Stpt	IFW	1AO	Power Loss - Cprsr A	CAR
8A	Chilled Water Flow (Ent Wtr Temp)	MMR	1A1	Power Loss - Cprsr 8	CAR
8E	Evap Entering Water Temp Sensor	MMR	1A2	Power Loss - Cprsr C	CAR
8F	Cond Rfght Temp Sensor - Ckt I	CMR	1A3	Power Loss - Cprsr D	CAR
90	Cond Rfght Temp Sensor - Ckt 2	CMR	1A4	Remote communications Loss	IFW
93	Evap Rfght Temp Sensor - Ckt I	CMR	1A5	Oil Flow Control - Cprsr A	CMR
94	Evap Rfght Temp Sensor - Ckt 2	CMR	1A6	Oil Flow Control - Cprsr B	CMR
A0	Zone Temp Sensor	IFW	1A7	Oil Flow Control - Cprsr C	CMR
A1	Outdoor Air Temp Sensor	IFW	1A8	Oil Flow Control - Cprsr D	CMR
Ab	Evap Leaving Wtr Temp Sensor	MMR	1A9	EXV Elec Drive Ckt - Rfght Ckt I	CMR
bA	Overload Trip - Cprsr A	CMR	1AA	EXV Elec Drive Ckt - Rfght Ckt 2	CMR
bb	Overload Trip - Cprsr 0	CMR	1Ad	Memory Error Type I (See Oper Manual)	IFW
bC	Overload Trip - Cprsr C	CMR	1AE	Low Differential Press - Ckt I	CMR
bd	Overload Trip - Cprsr D	CMR	1AF	Low Differential Press - Ckt 2	CMR
bE	High Pressure Cutout - Cprsr C	CMR	1b2	Severe Phase Unbalance - Cprsr A	CMR
bF	High Pressure Cutout - Cprsr D	CMR	1b3	Severe Phase Unbalance - Cprsr B	CMR
C5	Low Chilled Water Temp (Unit off)	IFW	1b4	Severe Phase Unbalance - Cprsr C	CMR
C6	Low Chilled Water Temp (Unit on)	MAR	1b5	Severs Phase Unbalance - Cprsr 0	CMR
CA	Contactor - Cprsr A	MMR	1b6	Compressor Overload Setting - Cprsr A	IFW
Cb	Contactor - Cprsr B	MMR	1b7	Compressor Over load Setting - Cprsr B	IFW
cc	Contactor - Cprsr C	MMR	1b8	Compressor Overload Setting - Cprsr C	IFW
Cd	Contactor - Cprsr D	MMR	1b9	Compressor Overload Setting - Cprsr D	IFW
d7	Over Voltage	MAR	1bA	Phase Unbalance - Cprsr A	CMR
d8	Under Voltage	MAR	1bb	Phase Unbalance - Cprsr 8	CMR
Ed	Chilled Water Flow Interlock	MAR	1bC	Phase Unbalance - Cprsr C	CMR
F5	High Pressure Cutout - Cprsr A	CMR	1bd	Phase Unbalance - Cprsr D	CMR
F6	High Pressure Cutout - Cprsr B	CMR	1bE	Winding Temp. - Cprsr A	CMR
Fd	Emergency Stop Input	MMR	1bF	Winding Temp. - Cprsr B	CMR
180	Starter Transition - Cprsr A	CMR	1C0	Winding Temp. - Cprsr C	CMR
181	Starter Transition - Cprsr B	CMR	1C1	Winding Temp. - Cprsr D	CMR
182	Starter Transition - Cprsr C	CMR	1C2	Discharge Temp. - Cprsr A	CMR
183	Starter Transition - Cprsr D	CMR	1C3	Discharge Temp. - Cprsr 8	CMR
184	Phase Reversal - Cprsr A	CMR	1C4	Discharge Temp. - Cprsr C	CMR
185	Phase Reversal - Cprsr 8	CMR	1C5	Discharge Temp. - Cprsr D	CMR
186	Phase Reversal - Cprsr C	CMR	1C6	High Differential Pressure - Ckt I	CMR
187	Phase Reversal - Cprsr D	CMR	1C7	High Differential Pressure - Ckt 2	CMR
190	Low Superheat - Ckt I	CMR	1d1	Memory Error Type 11 (See Oper Manual)	IFW
191	Low Superheat - Ckt 2	CMR	1d2	Memory Error Type III (See Oper Manual)	IFW
194	Low Evap Rfght Temp - Ckt I	CMR	1d3	Cprsr Suction Temp. Sensor - Ckt 1	CMR
195	Low Evap Rfght Temp - Ckt 2	CMR	1d4	Cprsr Suction Temp. Sensor - Ckt 2	CMR
198	Low Oil I Flow - Cprsr A	CMR	1d7	Phase Reversal Prot. Lost - Cprsr A	CMR
199	Low O1 1 Flow - Cprsr B	CMR	1d8	Phase Reversal Prot. Lost - Cprsr B	CMR
19A	Low Oil Flow - Cprsr C	CMR	1d9	Phase Reversal Prot. Lost - Cprsr C	CMR
19b	Low Oil Flow - Cprsr D	CMR	1dA	Phase Reversal Prot. Lost - Cprsr D	CMR
19C	Phase Loss - Cprsr A	CMR	1db	Slave-Exv Elec Drive Ckt - Rfght Ckt 1	CMR
19d	Phase Lose - Cprsr B	CMR	1dc	Slave-Exv Elec Drive Ckt - Rfght Ckt 2	CMR
19E	Phase Loss - Cprsr C	CMR	4xy	See Operator's Manual	---

X3956048201 Rev. B

Chiller Switch

The chiller switch has three positions:

Top Position	AUTO REMOTE
Middle Position	AUTO LOCAL
Bottom Position	STOP/RESET

With the switch in the AUTO REMOTE position, the chiller will operate normally using remote setpoints. Read and write remote communications may be performed. Any call for cooling based on Leaving Water Temperature (LWT) and the remote (e.g. Tracer) setpoints, will start the unit. The active chilled water setpoint (CWS) can be the remote CWS, a reset remote setpoint based on return, zone, or outdoor temperature reset, or a 4-20 mA/0-10 VDC external CWS. The active Current Limit Setpoint (CLS) can be the Remote CLS or a 4-20 mA/0-10 VDC External CLS. If remote communication is lost, the UCM will revert to the Front Panel (or local) chiller settings.

When the chiller switch is in the AUTO LOCAL position, the chiller will operate normally using Front Panel (or local) setpoints. Read and write remote communications may be performed, but remote setpoints cannot be used for control. The unit will run when there is a call for cooling based on the LWT and the Front Panel or local setpoints. The active CWS can be the local setpoint, a reset setpoint based on return, zone, or outdoor temperature reset, or a 4-20 mA/0-10 VDC external CWS. The active Current Limit Setpoint can be the local setpoint or a 4-20 mA/0-10 VDC External CLS. Remote (e.g. Tracer) setpoints communicated over the serial communications link will be ignored, but remote devices can still read all unit control data.

In the STOP/RESET position, the UCM is powered but operation of the unit is prevented. All outputs are de-energized and the chiller is stopped. The alarm relay output may be energized if an alarm condition exists.

If any of the chillers are running when the chiller is put into the STOP/RESET position, the chiller will go into the Run: Unload mode for at least 20 seconds before shutting down the compressors.

Although not a "position" on the chiller switch, it can be used to perform the function of manually resetting all latching diagnostics and clearing all historic diagnostics. Latching diagnostics can be reset by manually toggling the chiller switch from the STOP/RESET position to either AUTO position.

Historic diagnostics ("C" menu item) can be cleared by depressing the "Display Down" key while manually toggling the chiller switch from the STOP/RESET position to either AUTO position (no compressor operating).

Moving the chiller switch from the STOP/RESET position to either AUTO position will reset the controls, with one exception. If the chiller operating status is Run:Unload, this sequence will go to completion before the reset is executed. During the completion of the Run:Unload, the reset is "queued up" and operated on only after completion of the Run:Unload. After reset is completed, the digital display will return to "A" Operating Code.

Menu Function Descriptions and Selection

Selecting Variables and Options

All variables and options will be set by depressing the SET POINT UP and SET POINT DOWN keys. The setpoints will be increased or decreased by one least significant digit (1 F, 0.1 C, or 1 integer value) with each key depression. If the key is held down, the setpoint will continue to be increased or decreased until the key is released. The minimum and maximum values of all setpoints are limited by system design and the setting operation will stop when either the minimum or maximum setpoint is displayed. See Figure 52 for setpoint ranges.

Options are also selected using the SET POINT UP and SET POINT DOWN keys. Use the SET POINT UP key to select the "Enable" option and the letter "E" will appear on the display. Use the SET POINT DOWN key to select the "Disable" option and the letter "d" will be displayed. Certain items in Menus 4 and 5 will be integers with various endpoints and units. See Figure 52.

Menu 0 – Operating Display

A - Operating Code: This is the current unit operating status, e.g. A 74, which, as shown in Figure 53, is Run:Normal.

b - Last Diagnostic Code: The last diagnostic detected by the UCM is stored and can be seen by displaying this I item.

C - Other Diagnostics: All diagnostics detected by the UCM will be stored in preprescribed code number sequence, as shown in Figure 53, rather than the order in which they occurred. All flashing codes found under this item are currently active or "Latched" diagnostics. For additional information, see "Menus".

Diagnostics will be stored only once, even though the diagnostic may have occurred several times. There is no chronological sequence to the diagnostics that may be in the "C" menu item.

d - Active Chilled Water Setpoint: The setpoint (display only) to which the chiller is controlling. This may be the same as the Front Panel Chilled water Setpoint (code 10 in Menu 1), but it may also be a setpoint that is being reset or loaded from a remote controller, such as a Tracer, multiple-machine controller, or a remote display panel.

E - Evap. Entering Water Temp.: The temperature of the water as measured by the evaporator entering water temperature sensor. F - Evap. Leaving Water Temp.: The temperature of the water as measured by the evaporator leaving water temperature sensor.

L - Active Current Limit Setpoint: The current limit setpoint (display only) to which the chiller is controlled. This may be the same as the Front Panel Current Limit setpoint (code 13 in Menu 1), but it may also be a setpoint that was loaded from a remote controller, such as a Tracer, multiple-machine controller.

Menu 1 – Service #1 Display

10 - Front Panel Chilled Water Setpoint: The temperature selected at the UCM for the desired chilled water.

11 - Design Delta Temp. Setpoint: The difference between the entering and leaving chilled water temperatures at full load. This will be a function of GPM through the evaporator.

12 - Differential To Start Setpoint: This temperature, when added to the leaving chilled water setpoint, is the temperature at which the chiller will be started.

Note: 1.5 F below chill water setpoint, the UCM will initiate an integrator to shut off the last compressor on a decrease in cooling load.

13 - Front Panel Current Limit Setpoint, The percent of current limit selected at the UCM for the system. See discussion in "Current Limit Setpoint".

14 - Outdoor Air Temperature (Optional): The ambient temperature as measured by an outdoor temperature sensor.

15 - Low Ambient Lockout (Optional): If the unit is installed with optional Outdoor Air Temperature Sensor, the entry in this code will enable or disable the setpoint in code 16. See discussion in "Low Ambient Lockout".

16 - Low Amb. Lockout Setpoint (Optional): The temperature of the outside air below which the unit will not be permitted to operate. See discussion in "Low Ambient Lockout".

17 - Cond. Entering Wtr. Temp.: Not applicable, with this air-cooled condenser unit.

18 - Cond. Leaving Wtr. Temp.: Not applicable, with this air-cooled condenser unit.

19 - Service Pumpdown: Must be manually "Enabled" by service personnel from the UCM display. The unit must be in STOP/RESET and service pumpdown can be performed only once for every power-up of the UCM. Restart inhibit will be ignored, the EXV will be prepositioned (20 seconds) and the compressor selected will start and run for one minute. Manual closing of the liquid line angle valve will be required.

Caution: Do not pumpdown compressor more than once.

1A -Circuit Lockout: Allows service personnel to set a lockout, preventing a circuit from operating. With the display indicating the number of the circuit to be locked out, change the display to "E" for circuit lockout. Once circuit lockout is enabled, the circuit will remain locked out even through a reset or power down. Entering a "d" will return the circuit to operational status.

1b - Circuit Diagnostic Reset: Allows service personnel to reset a Circuit Manual Reset (CMR) diagnostic without having to terminate operation of the entire chiller via the STOP/RESET switch. With the display indicating the number of the circuit to be reset, change the display to "E" to reset. After reset, the display will automatically return to "d".

Menu 2 - Service #2 Display

20 - Compressor Mode: The current compressor operating status, as shown in Figure 53, will be displayed when this menu item is selected.

21 - Compressor Suction Rfgt Temperature: Temperature as read by the suction temperature sensor (see Figure 40).

22 - Saturated Evaporator Rfgt Temperature: Temperature as read by the saturated evaporator temperature sensor (see Figure 40).

23 - Evaporator Refrigerant Pressure: The pressure displayed is the evaporator refrigerant temperature converted to an R-22 pressure. Units are PSIG (Kilopascal gauge), referenced to sea level (14.6960 psia or 101.3289 KPa absolute).

24 - Saturated Condenser Rfgt Temperature: Temperature as read by the saturated condensing temperature sensor (see Figure 40).

25 - Condenser Refrigerant Pressure: The pressure displayed is the condenser refrigerant temperature converted to an R-22 pressure. Units are PSIG (Kilopascal gauge), referenced to sea level (14.6960 psia or 101.3289 KPa absolute).

26 - EXV Test: EXV test will be initiated when the unit is in STOP/RESET and EXV Test is set to the "Enable" mode. See "Electronic Expansion Valve (EXV) Test". Mode will automatically be reset to "disable" upon completion of the test.

27 - Compressor % RLA: The percentage of Rated Load Amps on the highest leg of the compressor motor. See discussion in "Current Overload Protection".

28 - % Line Volts (Optional): If the unit is installed with the optional over/under voltage transformer, the UCM will display the percentage value of line volts as based on the nominal line voltage set in Menu 4, Item 45.

29 - Compressor Starts (Optional): This item serves as a non-resettable, non-volatile accumulator of compressor starts and is referenced by the UCM to determine balancing of compressor starts.

2A - Compressor Hours (Optional): This item serves as a non-resettable, non-volatile accumulator of compressor hours and is referenced by the UCM to determine balancing of compressor hours.

2b - Compressor Test: Allows service personnel to start a compressor and check its operation. This eliminates the time of waiting for the UCM lead/lag function or load demand to start a compressor. With the display indicating the number of the circuit to be started, change the display to "E" to start the compressor on that circuit. After start, the display will automatically return to "d" and the UCM will resume its lead/lag function of compressor control.

Menu 3 - Auxiliary Options

30 - External Chilled Water Setpoint: Enables or disables chilled water setpoint from an external control system. See discussion in "Leaving Chilled Water Temperature Control".

31 - External Current Limit Setpoint: Enables or disables current limit setpoint for the system from an external control system. See discussion in "Current Limit Setpoint".

32 - Ice Making Control: Enables or disables the unit, when commanded by a contact closure, to run fully loaded and to stop, once ice termination setpoint has been reached, e.g. ice storage applications.

33 - Active Ice Termination Setpoint: The selected temperature, from a remote controller, such as a Tracer, multiple-machine controller, or a remote display panel, at which to terminate the ice building mode, based on the evaporator entering water temperature. If no remote controllers are connected, this setpoint should agree with the Front Panel ice termination setpoint. During normal operation, this menu item will display dashes, e.g. "33 -".

34 - Front Panel Ice Termination Setpoint: Established the temperature of the entering chilled water at which ice making is terminated. This setpoint is the active setpoint when the chiller is in the AUTO/LOCAL, ice mode.

35 - Return Reset: Enables or disables Return CWR, based on the current Delta-T across the evaporator (e.g: Entering Chilled Water Temp. - Leaving Chilled Water Temp.).

36 - Zone Reset: Enables or disables Zone CWR, based on a zone temperature sensor.

37 - Outdoor Reset: Enables or disables Outdoor CWR, based on an outdoor temperature sensor.

38 - Reset Ratio Setpoint: The reset ratio, as a percent, to be used by the UCM to calculate a reset chilled water setpoint. See discussion in "Chilled Water Reset".

39 - Start Reset Setpoint: The start reset temperature to be used by the UCM to calculate a reset chilled water setpoint. See discussion in "Chilled Water Reset".

3A - Maximum Reset Setpoint: The maximum reset temperature to be used by the UCM to calculate a reset chilled water setpoint. See discussion in "Chilled Water Reset".

3b - External Circuit Lockout: When enabled, individual circuit operation is controlled by a remote, customer specified/installed contact closure. See External Circuit Lockout -Circuit #1 and External Circuit Lockout -Circuit #2 in the Installation - Electrical section.

Menu 4 – Factory Display #1

40 - Leaving Water Temp. Cutout Setpoint: Establishes a leaving chilled water temperature, below which the UCM will begin unloading compressors and, if necessary, terminate unit operation. See discussion in "Leaving Water Temperature Cutout". See Table 15 for proper settings.

41 - Low Refrigerant Temp. Cutout Setpoint: Establishes a saturated evaporator refrigerant temperature, below which the UCM will begin unloading compressors and, if necessary, terminate unit operation. See discussion in "Low Refrigerant Temperature Cutout". See Table 15 for proper settings.

**Table 15
Leaving Fluid Temperature Setpoints**

Chilled Water Setpoint - F	Leaving Water Temp Cut out - F	Low Refrig Temp Cut out - F	Recommended *** % Ethylene Glycol	Solution Freeze Point - F
40	35	22	0	32
39	34	20	3	
38	33	18	6	
37	32	17	8	
36	31	15	10	25
35	30	14	12	
34	29	12	14	
33	28	11	15	21
32	27	9	17	
31	26	7	19	
30	25	6	20	16
29	24	4	21	
28	23	2	23	
27	22	0	25	10
26	21	-1	26	
25	20	-3	28	
24	19	-5	29	
23	18	-6	30	4
22	17	-8	31	
21	16	-10	33	
20	15	-11	34	
19	14	-13	35	-3
18	13	-15	36	
17	12	-17	37	
16	11	-18	38	
15	10	-19	39	
14	9	-21	40	-11
13	8	-23	41	
12	7	-24	42	
11	6	-26	43	
10	5	-27	43	
9	4	-29	44	
8	3	-31	45	-21
7	2	-32	46	
6	1	-34	47	
5	0	-35	47	
4	-1	-37	48	
3	-2	-38	49	
2	-3	-39	50	-32
1	-4	-39	50	
0	-5	-39	50	

*** Recommended % Ethylene Glycol will give freeze protection consistent with other chiller safety controls (solution freeze point is nominally 10 F above refig temp cutout).

42 - Condenser Limit Setpoint: Establishes a percentage of the condenser high pressure cutout, above which the UCM will begin unloading compressors and, if necessary, terminate unit operation.

43 - Lead Lag: Enables or disables the Auto Lead/Lag feature. See discussion in "Auto Lead/Lag".

44 - SI Display Units: When set to "Enable", the display units are converted from OF to IC and PSIG to Kilopascals Gauge.

45 - Unit Line Voltage (Optional): Establishes the line voltage coming into the unit and calibrates the UCM for Under/Over voltage protection and display of % volts. See "Unit Power Supply".

46 - Under/Over Voltage Protection (Optional): Enables or disables the optional under/over voltage protection feature, if installed.

47 - Phase Unbalance Protection: Enables or disables the phase unbalance protection feature. See discussion in "Phase Unbalance Protection".

48 - Phase Reversal Protection: Enables or disables the phase reversal protection feature. See discussion in "Reverse Rotation Protection".

49 - Superheat Setpoint: Establishes the temperature of the refrigerant superheat in the evaporator.

4A - EXV Control Response Setpoint: Establishes EXV control responsiveness. If the control appears to be too responsive, decrease the setpoint. Increase the setpoint if the control appears to be sluggish. The UCM-based default is designed to handle most applications and adjustment is usually not necessary.

4b - LWT Control Response Setpoint: Establishes LWT control responsiveness. If the control appears to be too responsive, decrease the setpoint. Increase the setpoint if the control appears to be sluggish. The UCM-based default is designed to handle most applications and adjustment is usually not necessary.

4C - ICS Address (Optional): Sets the address at which a remote controller, such as a Tracer, multiple-machine or a remote display panel, can find the chiller on a Bidirectional Communications Interface. To use this interface, the optional 1U2 module must be installed. The Tracer will look for the chiller at addresses 55, 56, 57, 58, 59 or 60. The UCM-based default is address 55. When multiple chillers are connected to the Bidirectional Communications Interface, each chiller must have a unique address, e.g. 55, 56 and 57 for three chillers.

For chillers with the Remote Display Panel, set the address to "32". See RTAA-IOM-2 for further information on Remote Display Panel.

4d - Fan Control Deadband Bias Provides sensitivity adjustment of condensing fan control logic. Must be set at "0". Settings other than "0" are not permitted.

4E - Programmable Relays Setup: Used for selection of the Alarm/Running/Maximum Capacity contact outputs. See Alarm/Running/Maximum Capacity Outputs in the Installation - Electrical section.

4F - Restart Inhibit Timer: Used to adjust the time (in seconds) between the power-up of a unit (or the switching from the STOP/RESET position) and the initiation of the compressor start sequence, provided there is a call for cooling. The typical setting is 120 seconds, but a time as short as 30 seconds may be set.

Note: The anti-recycle timer, which provides 5 minutes between start cycles, is not affected by this menu item.

Menu 5 – Factory Display #2

- 50 - Number of Compressors: Set to the number of compressor installed in the unit.
- 51 - Compressor Tons: Set to the rating in tons, of the each installed compressor. See Table 2.
- 52 - Low Water Temperature EXV Gain Compensation: Set to "E" if the unit will ever operate with a leaving chilled water temperature of 40 F or less.
- 53 - Fan Control: Set to "E".
- 54 - Fans Per Circuit: Establishes the number of fans installed on each circuit. See Figures 45 and 46.
- 55 - Reduced Inrush Starting: Set to "d" if across-the-line wiring or to "E" if Wye-Delta wiring.
- 56 - Compressor Current Overload Setting: Establishes the compressor motor current overload setting, which must agree with the DIP Switch settings on the corresponding compressor modules. See Table 16.

Compressor	Compressor Module
A	1U4
B	1U5
C	1U6
D	1U7

57 - GP Compressor Unit: This menu item must be set to "d". The unit is not to be operated unless a "d" is displayed in this item.

58 - Low Ambient, Half Airflow Fan (Halfpitch Blades on Lead Fan(s): Set this menu item per the following unit selections

- RTAA 130 - 200 Standard Ambient = d
- RTAA 130 - 200 Low Ambient = E
- RTAA 240 - 400 All = E

59 - LATSM: Set this menu item to "d".

5A - NNS: Set this menu item to "d".

5b - Number of EXV Valves per Circuit: Set this menu item per the following unit selections

- RTAA 130 - 200 Circuit 1 = 1
- Circuit 2 = 1
- RTAA 240 - 300 Circuit 1 = 2
- Circuit 2 = 1
- RTAA 340 - 400 Circuit 1 = 2
- Circuit 2 = 2

5C - Future Option: Set this menu item to "d" for both Circuit #1 and Circuit #2.

**Table 16
Compressor Overload DIP Switch Settings**

Compressor Tons	Volts.Hz	RLA	CT Ext*	Overload Setting DIP Sw/Decimal** 12345
70	200/230.60	280	-05	00100/04
	460.60	122	-02	10000/16
	575.60	98	-01	11110/30
85	200/230.60	306	-05	01011/11
	460.60	133	-02	10110122
	575.60	107	-02	00110/06
100	200/230.60	375	-05	11010/26
	460.60	163	-03	10000/16
	575.60	131	-02	10110122

*The CT base part number is X13580253. The numbers in this column are suffixes to the base number.

**On the DIP switch, 1= ON, 0= OFF. The decimal number is the setting Menu Item 56. The DIP switch setting and the decimal display of Item 56 comprise a redundant overload setting. If the values are not set to match, the related compressor(s) will continue to run, but a diagnostic will be initiated, both settings will be ignored, and the UCM will use the lowest possible trip setting value.

Operational Features

Entering Evaporator Water Temperature

When one or more compressors are running, the UCM continually monitors and compares the entering and leaving evaporator water temperatures. If the temperature of the entering water drops more than 2 F below the leaving water temperature for more than 100 degree F seconds, the UCM uses this to indicate a loss of water flow through the evaporator, will shut down the chiller and will display an MMR diagnostic. See Figure 53.

Current Limit Setpoint

The current limit setpoint (CLS) for the chiller (front panel or remote) is entered through the UCM menu. The current limit setpoint for each compressor is shown in Table 17.

Based upon current levels received at the UCM, the compressor slide valve is modulated to prevent the actual chiller current from exceeding the CLS.

When a compressor is turned off, the CLS for the remaining running compressors shall be reset upward immediately. When a compressor is added, the CLS for the running compressors shall ramped downward at a rate not less than 10% RLA per minute to the new setpoint.

Low Ambient Lockout

The lockout provides a method for preventing unit start-up when the outdoor air temperature is below the setpoint. If the outdoor temperature goes below the setpoint during operation, the UCM will go through a normal shutdown of the unit. If the outdoor temperature subsequently increases to 5 F above the setpoint, the UCM will automatically re-enable the unit.

Electronic Expansion Valve (EXV) Test

This test can be performed only when the chiller switch is in the STOP/RESET position. It will confirm proper operation of the electronic expansion valve and the EXV module.

Once the test has been initiated at the UCM, the UCM will:

1. Overdrive the EXV closed (1250 steps)
2. Overdrive the EXV open (1250 steps)
3. Overdrive the EXV closed (1250 steps)
4. Reset the display to disable and end the test

The EXV produces an audible clicking sound only when it is driven against its end stops. Step 1 drives the EXV to its closed position, during which time service personnel can move from the UCM to the EXV.

Note: A tool may be needed to aid in hearing the clicking of the EXV, such as a screwdriver held between the EXV and the ear.

When Step 1 completes, the clicking stops and the UCM begins to open the EXV. When the EXV is fully opened, the valve will begin to click against its end stop. The service personnel must be prepared to time the period between the end of clicking in Step 1 and the beginning of clicking in Step 2.

The time between the end of clicking in Step 2 and the beginning of clicking in Step 3 must also be recorded. The time for the EXV to go from fully closed to fully open should be approximately 15 seconds and the time to go back to fully closed is approximately 15 seconds.

Current Overload Protection

The UCM continually monitors compressor current to provide unit protection in the event of an overcurrent or locked rotor condition. Protection is based on the phase with the highest current and, if limits are exceeded, the UCM will shutdown the compressor and will display an CMR diagnostic. See Figure 53.

Leaving Chilled Water Temperature Control

If the chiller switch is in the AUTO REMOTE position and a remote chilled water setpoint has been communicated, the UCM will control to that setpoint. Otherwise, it will control to the front panel setpoint. Control is accomplished by both staging compressors and modulating the slide valves on each compressor.

Upon start-up, if the leaving water temperature is dropping 1.5 F per minute or faster, the chiller will not load further.

Table 17
Compressor(s) Current Limit Setpoint vs Chiller Current Limit Setpoint (CLS)

System CLS	Number of Compressors on a Unit								
	Two (130-215)		Three (240-300)			Four (340-400)			
	Number of compressors in operation		Number of compressors in operation			Number of compressors in operation			
	One	Two	One	Two	Three	One	Two	Three	Four
120%	120	120	120	120	120	120	120	120	120
100%	120	100	120	120	100	120	120	120	100
80%	120	80	120	120	80	120	120	107	80
60%	120	60	120	90	60	120	120	80	60
40%	80	40	120	60	40	120	80	53	40

Chilled Water Reset (CWR)

As an option, the UCM will reset the chilled water temperature setpoint, based on either the return water temperature, zone air temperature, or outdoor air temperature. The following are selectable:

1. One of four RESET TYPEs, from top to bottom in order of reset:

no CWR
 RETURN WATER
 TEMPERATURE RESET ZONE
 TEMPERATURE RESET
 OUTDOOR AIR TEMPERATURE
 RESET

The UCM will not permit more than one type of reset to be selected in Menu 3.

2. RESET RATIO Setpoints. For OUTDOOR AIR TEMPERATURE RESET, there are both positive and negative reset ratios.
3. START RESET Setpoints.
4. MAXIMUM RESET Setpoints. The maximum resets are with respect to the chilled water setpoint.

No matter which type of reset is selected, all parameters are factory set to a predetermined set of values. Field adjustment of 2, 3, or 4, above, is usually not required.

The equations for each type of reset are:

RETURN WATER TEMPERATURE RESET

$$CWS' = CWS + \text{RESET RATIO} [\text{START RESET} - (\text{TWE} - \text{TWL})]$$

and $CWS' > \text{or} = CWS$

and $CWS' - CWS < \text{or} = \text{MAXIMUM RESET}$

ZONE TEMPERATURE RESET

$$CWS' = CWS + \text{RESET RATIO} [\text{START RESET} - \text{TZONE}]$$

and $CWS' > \text{or} = CWS$

and $CWS' - CWS < \text{or} = \text{MAXIMUM RESET}$

OUTDOOR AIR TEMPERATURE RESET

$$CWS' = CWS + \text{RESET RATIO} [\text{START RESET} - \text{TOD}]$$

and $CWS' > \text{or} = CWS$

and $CWS' - CWS < \text{or} = \text{MAXIMUM RESET}$

CWS' is the new chilled water setpoint.

CWS is the active chilled water setpoint before any reset has occurred.

RESET RATIO is a user adjustable gain.

START RESET is a user adjustable reference.

TZONE is the zone temperature.

TOD is the outdoor temperature.

TWE is the entering evaporator water temperature.

TWL is the leaving evaporator water temperature.

MAXIMUM RESET is a user adjustable limit, providing the maximum amount of reset.

Note: When any type of CWR is enabled, the UCM will step the CWS toward the desired CWS' (based on the above equations and setup parameters) at a rate of 1 F every 5 minutes. This applies when the chiller is both running and off. Normally the chiller will start at the Differential-to-Start value above a fully reset CWS or CWS'.

The values for RESET RATIO for each type of reset are:

Reset Type	Reset Ratio Range	Increment English Units	Increment SI Units	Factory Default Value
Return	10 to 120%	1%	1%	50%
Zone	50 to 300%	1%	1%	100%
Outdoor	80 to -80%	1%	1%	10%

The values for START RESET for each type of reset are:

Reset Type	Start Reset Range	Increment English Units	Increment SI Units	Factory Default Value
Return	4 to 30 F (2.2 to 16.7 C)	1 F	0.1 C	10 F (5.6 C)
Zone	55 to 85 F (12.8 to 29.4 C)	1 F	0.1 C	78 F (25.6 C)
Outdoor	50 to 130 F (10 to 54.4 C)	1 F	0.1 C	90 F (32.2 C)

The values for MAXIMUM RESET for each type of reset are:

Reset Type	Maximum Reset Range	Increment English Units	Increment SI Units	Factory Default Value
Return	0 to 20 F (-17.8 to -6.7 C)	1 F	0.1 C	5 F (2.8 C)
Zone	0 to 20 F (- 17.8 to -6.7 C)	1 F	0.1 C	5 F (2.8 C)
Outdoor	0 to 20 F (- 17.8 to -6.7 C)	1 F	0.1 C	5 F (2.8 C)

Leaving Water Temperature Cutout

This temperature cutout provides protection against freezing caused by low leaving water temperature. The setpoint is both factory set and adjustable from Menu 4. Temperatures below the setpoint will cause the UCM to accelerate reduction of chiller capacity, even to the point of compressor shutdown. A non-latching diagnostic will be generated if the LWT is below the cutout for more than 30 degree F seconds.

There must be a minimum of 5 F between the cutout temperature and both the front panel and active chilled water setpoints. The UCM will not permit setting of either the front panel or active chilled water temperatures less than 5 F above this cutout temperature and the display will flash the last valid temperature.

If the leaving water temperature cutout is set upward, the UCM will maintain the 5 F minimum and will raise the settings on the front panel and active chilled water setpoints, if necessary.

Low Refrigerant Temperature Cutout

Both circuits are protected from a saturated evaporator refrigerant temperature that goes below this setting. The cutout setpoint must be a minimum of 15 F lower than the front panel or active chilled water setpoints.

There must be a minimum of 15 F between the cutout temperature and both the front panel and active chilled water setpoints. The UCM will not permit setting of either the front panel or active chilled water temperatures less than 15 F above this cutout temperature and the display will flash the last valid temperature.

If the leaving water temperature cutout is set upward, the UCM will maintain the 15 F minimum and will raise the settings on the front panel and active chilled water setpoints, if necessary.

If the saturated evaporator refrigerant temperature for a circuit drops below this setpoint for longer than 30 degree F seconds, the circuit will be shutdown and a CMR diagnostic will be displayed.

Low Ambient Temperature Start

The Low Refrigerant Temperature Cutout (LRTC) on a circuit is ignored, briefly, each time the circuit is started. The "ignore time" is a function of the Saturated Condenser Refrigerant Temperature at the time the compressor starts, as shown in Figure 54.

Low Refrigerant Temperature Cutout Retry

If the LRTC trips despite the low ambient temperature start logic, the circuit will be permitted to shutdown and retry one time

If the LRTC trips within the first 20 minutes after initial start but after the Low Ambient ignore time (grace period), the compressor stops immediately and the Restart Inhibit timer is set to 1 minute. After time expires, the compressor will restart if there is a call for cooling.

If the LRTC trips again during the grace period, a CMR diagnostic will occur. If there is an LRTC trip anytime after the grace period, a CMR diagnostic will occur.

Figure 54
Low Refrigerant Temperature Cutout Ignore Time

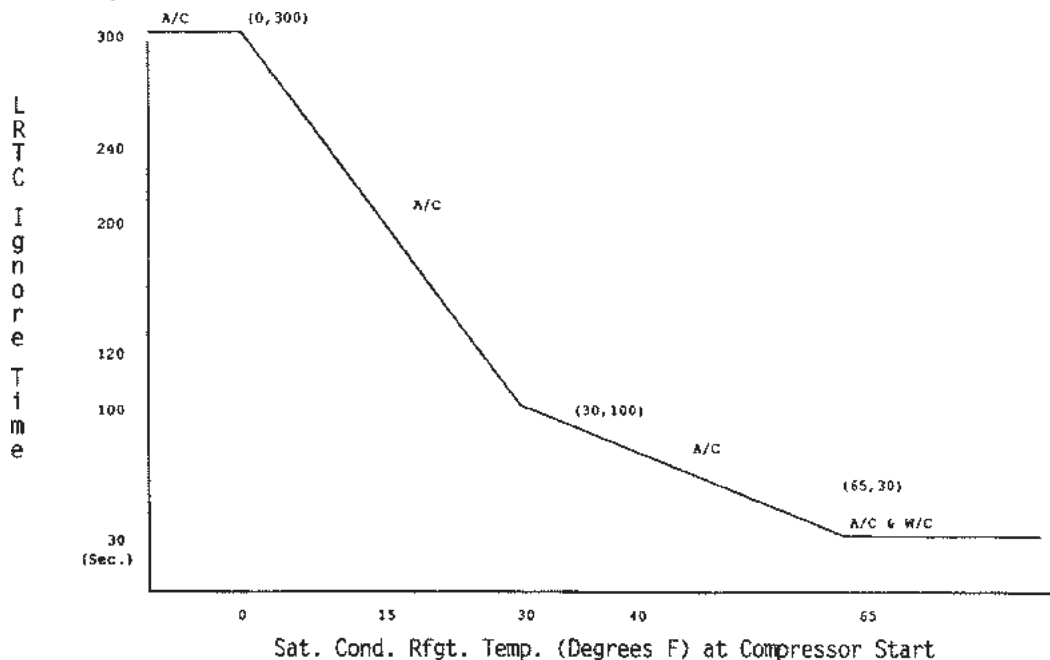

Low Refrigerant Temperature Cutout Time - vs - Saturated Condenser Refrigeration Temperature

Auto Lead/Lag

This feature is enabled/disabled in code 43, menu 4. When enabled, the UCM will start the compressor with the fewest starts and stop the compressor with the greatest hours, as determined by the "Compressor Starts" accumulator (code 29, menu 2) and the "Compressor Hours" (code 2A, menu 2). (Display is optional). This will tend to balance out hours and starts equally over all compressors. For efficiency improvement, when there are 2 compressors operating, they will be on opposite circuits. When disabled the compressors will start per the following chart.

RTAA	RTAA	RTAA
130-200	240-300	340-400
A	A	A
AB	AC	AC
ABC	ABC	ABCD

Phase Imbalance Protection

The UCM monitors the current in each phase and calculates the percentage of imbalance as follows:

$$\% \text{ Imbalance} = \frac{(I_x - I_{ave})}{I_{ave}} \times 100$$

$$I_{ave} = (I_1 + I_2 + I_3)^{1/3}$$

I_x = phase with greatest difference from I_{ave} (without regard to sign)

If code 47, menu 4, is enabled, and the average three phase current is greater than 80% RLA, and the percent of imbalance is calculated to exceed 15%, the UCM will shutdown the compressor and display a CMR diagnostic.

In addition to the 15% criteria, the UCM has a non-defeatable 30% criteria which has its own diagnostic. If the 15% criteria is enabled, it will always display the 15% diagnostic first. The 30% criteria is always active when a compressor is running, regardless of % RLA.

Reverse Rotation Protection

The UCM monitors incoming current during start-up and will shutdown the compressor within one second, if phase reversal is detected.

Caution: Phase relationships during installation of unit power must be carefully controlled to assure compressor protection against reversed phase rotation. See Installation - Electrical.

DIP Switch Settings

Compressor Overload DIP Switches

The settings for these switches are shown in Table 16.

IPC Address

The [PC address set the address for Inter-Processor Communications of the UCM modules. The following is the IPC DIP switch settings for the RTAA 130 400 modules.

IPC DIP SWITCH	MODULE					
	1U3	1U4	1U5	1U6	1U7	1U8
1	OFF	OFF	OFF	ON	ON	OFF
2	OFF	OFF	ON	OFF	ON	ON

2-10 VDC/4-20 mA Input for External Chilled Water Setpoint (CWS) and Current Limit Setpoint (CLS)

When either external CWS or external CLS is used on the optional Module 1U2, DIP switch SW1 positions 1 and/or 2 must be set to accommodate the type of signal source the customer has chosen, either 2-10 VDC or 4-20 mA. SW1 - 1 sets 2-10 VDC/4- 20 mA for external CWS. SW1 - 2 sets 2-10 VDC/4- 20 mA for external CLS. The "OFF" setting configures the external input for 2-10 VDC; the "ON" setting configures the external input for 4-20 mA.

Diagnostics and Troubleshooting

If no diagnostics exist, the selected menu item will be displayed continuously. When a diagnostic occurs, the display will switch to the Menu "0" and, depending on the nature of the diagnostic, will do one of the following:

1. The display will "alternate" between the Operating Code "A" at the time of failure and the Diagnostic Code "C" for any condition that causes the entire shutdown (MMR and MAR diagnostics). The display will alternate between "A XX" and "C YY", where YY is the MMR or MAR diagnostic that caused the machine to shutdown. If multiple MMR or MAR diagnostics occur, YY will be the active diagnostic with the greatest priority. Priority, from the highest to lowest, shall be as follows:

Cd	Contactors - Cprsr D (MMR)
CC	Contactors - Cprsr C (MMR)
Cb	Contactors - Cprsr B (MMR)
CA	Contactors - Cprsr A (MMR)
413	CPM module indicates EXV module communications loss (MMR)
431	EXV Module indicates CPM module communications loss (MMR)
Fd	Emergency Stop (MMR)
Ab	Evaporator Leaving Water Temperature Sensor (MMR)
8E	Evaporator Entering Water Temperature Sensor (MMR)
8A	Chilled Water Flow (Entering Water Temperature) (MMR)
d8	Under Voltage (MAR)
d7	Over Voltage (MAR)
Ed	Chilled Water Flow Interlock (MAR)
C6	Low Chilled Water Temp. (Unit On) (MAR)

When multiple diagnostics exist and a diagnostic with a higher priority is no longer active, the diagnostic with lower priority will replace it in the alternating "A XX" and "C YY" displays.

Note: MMR diagnostics only become inactive after a RESET MAR diagnostics become inactive when the condition that caused them clears.

2. The display will flash the Current Operating Code "A", followed by a fully blank display for all other diagnostics (CMR, CAR, and IFW diagnostics). This is to call attention to the detection of some type of failure.

Depressing the Display Down key will advance the display to the "Last (most recent) Diagnostic Code". The display will "flash" if any diagnostic exists that requires a manual reset to restore full unit operation. The display will be continuous if no manual reset is required to restore full operation. The "Last Diagnostic Code" will be retained until the unit control is reset or a new diagnostic occurs.

Depressing the Display Down key will then cause the display to show any "Other Diagnostic Codes" that have occurred since the "Other Diagnostic Codes" was last reset. Any specific diagnostic will not be shown more than once, even if it has occurred more than once. No time sequence of occurrence is provided. The display will "flash" if the current logical status of the condition that caused the diagnostic still exists or if it is an MMR or MAR diagnostic. Flashing means the condition still exists if it is a MAR, CAR, or IFW diagnostic or that a manual reset is required if it is a MMR or CMR diagnostic.

By depressing the Display Down key after the last of the "Other Diagnostic Codes", the display can be advanced to setpoint adjustment, unit temperature, and other data displays.

Depressing the Display Down key following the last data display in the menu (either operating, service, auxiliary options, or factory) will return the display to the top of the display menu, "P Menu Number". If the menu selected is Menu 0 and either an MMR and MAR diagnostic is still active, when selected again, the operating code will "alternate" with the highest priority MMR or MAR, as in item 1. above. Otherwise, in all other cases, the current operating code will be displayed continuously.

If any diagnostics have been detected since the last unit reset, the "Last Diagnostic Code" will be cleared when the chiller switch is moved from the STOP/ RESET position to either of the AUTO positions. The display will show "A 88" for 0.5 to 5 sec. following the reset, before returning to the display of the operating code.

The above step will not clear the "Other Diagnostic Codes" menu item. To clear this, depress and hold the Display Down key while moving the chiller switch from the STOP/RESET position to either of the AUTO positions.

Mechanical Control Settings

The settings for the High Pressure switch, Oil Pressure switch, and Winding Thermostat are shown below:

	<u>CLOSE</u>	<u>OPEN</u>
Compressor Discharge High Pressure Switch - PSIG	300 ±20	405 ±7
Compressor Oil Pressure Switch -PSID	47	50 ±3
Compressor Motor Winding Thermostat - F	181	221
Domestic Water Heater Solenoid Thermostat - F	115	130

Table 18
Diagnostics and Troubleshooting Chart

In the table below, a "LATCHING" diagnostic is a condition which shall cause the machine or a portion of the machine as noted to shut down and shall require a manual reset to restore operation. A diagnostic that is non-latching shall reset automatically when the condition causing the diagnostic goes away. A non-latching diagnostic shall shut down the machine or a part of the machine if so indicated. If a diagnostic is informative only, no machine or circuit action is taken except to load a diagnostic code into the last diagnostic register.

Diagnostic Types (And Action)

MMR = Machine Shutdown, Manual Reset

MAR = Machine Shutdown, Auto Reset

CMR = Circuit Shutdown, Manual Reset

CAR = Circuit Shutdown, Auto Reset

IFW = Information/Warning

CODE	DIAGNOSTIC DESCRIPTION	TYPE	DIAG. ACTIVE MODES	CAUSE
87	External Chilled Water	IFW	All	a. Not "Enabled": No Diagnostics Setpoint b. "Enabled": Out-of-Range Low, set diagnostic. Out-of-Range Hi, no diagnostic.
89	External Current Limit	IFW	All	a. Not "Enabled": No Diagnostics Setpoint b. "Enabled": Out-of-Range Low, set diagnostic. Out-of-Range Hi, no diagnostic.
8A	Chilled Water Flow	MMR	Any Circuit Energized	a. The entering evaporator water fell (Ent. Wtr. Temp.) below the leaving evap. water temp. by more than 2 F for 100 F-seconds. b. Causes to trip this diagnostic loss of chilled water flow or a calibration shift in the evap. water temp. sensors.
8E	Evap. Entering Water Temp. Sensor	MMR	All	Open or Short
8F	Cond. Rfgt. Temp. Sensor - Ckt 1	CMR	All	Open or Short
90	Cord. Rfgt. Temp. Sensor - Ckt 2	CMR	All	Open or Short
93	Evap. Rfgt. Temp. Sensor - Ckt 1	CMR	All	Open or Short
94	Evap. Rfgt. Temp. Sensor - Ckt 2	CMR	All	Open or Short
9A	Cord. Entering Wtr. Temp. Sensor	IFW	All	Shorted condenser temperature sensor (no diagnostic on open circuit).
9b	Cond. Leaving Wtr. Temp. Sensor	IFW	All	Shorted condenser temperature sensor (no diagnostic on open circuit).
AO	Zone Temperature Sensor (Zone Reset Selected)	IFW	All	Open or Short a. Use end of range value (whatever value the open or short gives). b. Clear diag. when the resistance returns to normal range. c. If Shorted, go into the ice making mode if "Ice Machine Control" is enabled.
	Zone Temperature Sensor (Zone Reset Not Selected)	None	All	a. If Open, do normal chiller control . b. If Shorted, go into the ice making mode if "Ice Machine Control" is enabled.
A1	Outdoor Air Temp. Sensor (Either Outdoor Air Reset or Low Ambient Lockout Selected)	IFW	All	Open or Short a. Use end of range value (whatever value the open or short). b. Clear diag. when the resistance returns to normal range.

**Table 18
Diagnostics and Troubleshooting Chart (Continued)**

CODE	DIAGNOSTIC DESCRIPTION	TYPE	DIAG. ACTIVE MODES	CAUSE
NONE	Outdoor Air Temperature Sensor (Both Outdoor Air Reset or Low Ambient Lockout Not Selected)	None	All	Open or Short a. Display dashes e.g. 14 - - - - -"
Ab	Evap. Leaving Water Temp. Sensor	MMR	All	Open or Short
bA	Overload Trip - Compressor A	CMR	Compressor Energized	Compressor current exceeded overload time vs. trip characteristic.
bb	Overload Trip - Compressor B	CMR	Compressor Energized	Compressor current exceeded overload time vs. trip characteristic.
bC	Overload Trip - Compressor C	CMR	Compressor Energized	Compressor current exceeded overload time vs. trip characteristic.
bd	Overload Trip - Compressor D	CMR	Compressor Energized	Compressor current exceeded overload time vs. trip characteristic.
bE	High Pressure Cutout - Compressor C	CMR	All	a. A high pressure cutout was detected on Compressor C; trip at 405 + or - 7 PSIG.
BF	High Pressure Cutout - Compressor D	CMR	All	a. A high pressure cutout was detected on Compressor D; trip at 405 + or - 7 PSIG.
NONE	CWS/Leaving Water Temp. Cutout Setpoint Overlap	None	All	No diagnostic, display to flash and limit value to last legal value.
NOTE: The above is not a diagnostic because you don't want the display vectoring you to a different display state when you are trying to set either the chilled water setpoint or the leaving water temp. cutout setpoint as it will in the case of a diagnostic.				
C5	Low Chilled Water Temperature (Unit Off)	IFW	No Circuits Energized	a. The chilled water temp. fell below the cutout setpoint while the compressors were not running.
C6	Low Chilled Water Temperature (Unit On)	MAR	Any Circuit Energized	a. The chilled water temp. fell below the cutout setpoint while the compressors were running for 30 F - sec.
CA	Contactors - Compressor A	MMR	Compressor Not Energized	a. Welded compressor contactor. b. Detected a welded compressor contactor off but the current does not go to zero. Detection time shall be 5 second minimum and 10 seconds maximum. On detection, generate the diagnostic, energize the appropriate alarm relay, continue to command the affected compressor off, energize the affected compressors oil line solenoid, stop all other compressors, unload the running compressor with the welded contactor, open the EXV to it's maximum open position, and continue to do fan control. Do not exit this condition until the controller is manually reset.
Cb	Contactors - Compressor B	MMR	Same as CA	Same as diagnostic CA
CC	Contactors - Compressor C	MMR	Same as CA	Same as diagnostic CA
Cd	Contactors - Compressor D	MMR	Same as CA	Same as diagnostic CA
d7	Over Voltage	MAR	Pre-start and Any Circuit(s) Energized	a. Line voltage above +10% of nominal. (Must hold = +10% of nominal. Must trip = +15% of nominal.)

**Table 18
Diagnostics and Troubleshooting Chart (Continued)**

CODE	DIAGNOSTIC DESCRIPTION	TYPE	DIAG. ACTIVE MODES	CAUSE
d8	Under Voltage	MAR	Pre-start and Any Circuit(s) Energized	a. Line voltage below -10% of nominal the Under/Over transformer is not connected. (Must hold = -10% of nominal Must trip = -15% of nominal).
Ed	Chilled Water Flow Interlock	MAR	All Modes Except STOP (00) and EXTERNAL STOP (100)	a. The chilled water flow switch input was open for more than 6 seconds.
F5	High Pressure Cutout - Compressor A	CMR	All	a. A high pressure cutout was detected on Compressor A; trip at 405 + or - 7 PSIG.
F6	High Pressure Cutout - Compressor B	CMR	All	a. A high pressure cutout was detected on Compressor B; trip at 405 + or - 7 PSIG.
Fd	Emergency Stop	MMR	All	a. EMERGENCY STOP input is open. An external interlock has tripped. Time to trip from input opening to unit stop shall be 0.1 to 1.0 sec.
180	Starter Transition Compressor A	CMR		a. The UCM did not receive a transition complete signal in the designated time from the UCM command to transition. The must hold time from the UCM transition command is 1 second. The Must trip time from the transition time is 6 seconds. b. The Transition Complete input was found to be shorted before the compressor was started. c. Active only if Reduced Inrush Starting is enabled.
181	Starter Transition - Compressor B	CMR	Same as 180	Same as diagnostic 180.
182	Starter Transition - Compressor C	CMR	Same as 180	Same as diagnostic 180.
183	Starter Transition - Compressor D	CMR	Same as 180	Same as diagnostic 180.
184	Phase Reversal - Compressor A	CMR		a. A phase reversal was detected on the incoming current. On a compressor start-up the phase reversal logic must detect and trip in a maximum of 1.0 second from compressor start.
185	Phase Reversal - Compressor B	CMR		Same as diagnostic 184.
186	Phase Reversal - Compressor C	CMR		Same as diagnostic 184.
187	Phase Reversal Compressor D	CMR		Same as diagnostic 184.

Table 18
Diagnostics and Troubleshooting Chart (Continued)

CODE	DIAGNOSTIC DESCRIPTION	TYPE	DIAG. ACTIVE MODES	CAUSE
190	Low Superheat Circuit 1	CMR	All Running Modes	a. A low superheat condition existed for an extended period of time. If a superheat less than or equal to 2 F is detected for more than 2400 F seconds, the circuit shall be shut down. The integrated area (2400 F seconds) shall be only below 2 F superheat.
191	Low Superheat - Circuit 2	CMR	All Running Modes	Same as diagnostic 190.
194	Low Evap. Rfgt. Temp. - Circuit 1	CMR	Compressor Energized	a. The Saturated Evaporator Refrigerant Temp.- Circuit 1 dropped below the Low Refrigerant Temp. Cutout Setpoint when the circuit was running for 30 F seconds. b. See the low ambient ignore time on start-up.
195	Low Evap. Rfgt. Temp.	CMR	Compressor Energized	Same as diagnostic 194, but for Ckt 2.
198	Low Oil Flow - Compressor A	CMR	Compressor Energized	a. The differential oil pressure switch remained open for more than 20 contiguous seconds on Compressor A.
199	Low Oil Flow - Compressor B	CMR	Compressor Energized	Same as diagnostic 198, but for Cprsr B.
19A	Low Oil Flow - Compressor C	CMR	Compressor Energized	Same as diagnostic 198, but for Cprsr C.
19b	Low Oil Flow - Compressor D	CMR	Compressor Energized	Same as diagnostic 198, but for Cprsr D.
19C	Phase Loss Compressor A	CMR	Compressor Energized	a. No current was sensed on one or more of the current transformer inputs. (Must hold = 20% RLA. Must trip = 5% RLA.) Time to trip shall be 1 second minimum and 3 seconds maximum.
19d	Phase Loss Compressor B	CMR	Same as 19C	Same as diagnostics 19C
19E	Phase Loss Compressor C	CMR	Same as 19C	Same as diagnostics 19C
19F	Phase Loss Compressor D	CMR	Same as 19C	Same as diagnostics 19C
1A0	Power Loss Compressor A	CAR	All Running Modes	a. The compressor was running and all three phases of current were lost. b. There was an open Transition input after transition had been previously proven to have been complete. c. There was an incomplete Transition on the first check after transition and all three phases of current here not present.
1A1	Power Loss - Compressor B	CAR	Same as 1A0	Same as diagnostic 1A0.
1A2	Power Loss - Compressor C	CAR	Same as 1A0	Same as diagnostic 1A0.
1A3	Power Loss - Compressor D	CAR	Same as 1A0	Same as diagnostic 1A0.

**Table 18
Diagnostics and Troubleshooting Chart (Continued)**

CODE	DIAGNOSTIC DESCRIPTION	TYPE	DIAG. ACTIVE MODES	CAUSE
1A4	Remote Communications Loss	IFW	All AUTO/REMOTE Modes	<p>a. While the chiller switch was in the AUTO/REMOTE the communication between the CSR and the connected remote device, e.g. a Tracer or Remote Display, had either never been established for more than 15 minutes after power up or was lost for more than 15 minutes after it had been established; use the Front Panel Setpoints and the Default Chiller Auto/ Stop.</p> <p>b. In AUTO/LOCAL communications had been established and was then lost for more than 15 minutes. Regardless of the remote communication status the UCM uses Front Panel setpoints.</p>
			All AUTO/LOCAL and all STOP/RESET modes	
NOTE: The active modes for diagnostic 1A4 follows the positions of the chiller switch which account for other chiller codes.				
1A5	Oil Flow Control - Compressor A	CMR	Pre-Stop	<p>a. At the time the 20 second Run: Unload time times out, the UCM will de-energize the oil line solenoid and set a 10+ or -1 second timer. As soon as the differential pressure switch opens (0.8 to 1.2 sec.) the compressor will be de-energized and the sequence ended. If the differential pressure switch does not open within 10 seconds, the compressor shall be de-energized and a CMR diagnostic generated not permitting the compressor to restart. Whenever the fan control pressure differential is below 70 PSID, or if a diagnostic shutdown occurs, the above shutdown test will not be executed. The above test will serve to check the differential pressure switch, the switch wiring to the UCM, and closure of the oil line solenoid.</p>
1A6	Oil Flow Control -	CMR	Pre-Stop	Same as diagnostic 1A5. Compressor B
1A7	Oil Flow Control -	CMR	Pre-Stop	Same as diagnostic 1A5. Compressor C
1A8	Oil Flow Control -	CMR	Pre-Stop	Same as diagnostic 1A5. Compressor D
1A9	EXV Electrical Drive Circuit (Rfgt. Circuit 1)	CMR	Pre-Start and On Demand	<p>a. Wiring between the EXV and the UCM is "Open". Check the connector for proper termination.</p> <p>b. EXV motor is faulty.</p> <p>c. EXV drive circuits on Module 1U3 are faulty.</p>
1AA	EXV Electrical Drive Circuit (Rfgt. Circuit 2)	CMR	Pre-Start and On Demand	Same as diagnostic 1A9.
NOTE: For similar diagnostics for the Slaved EXV Drive Circuits see Codes 1 db and 1 dC.				

Table 18
Diagnostics and Troubleshooting Chart (Continued)

CODE	DIAGNOSTIC DESCRIPTION	TYPE	DIAG. ACTIVE MODES	CAUSE
1Ad	Memory Error Type I	IFW	UCM Power Up or Following a Type II Memory Error	a. On UCM power up or following a Type II Memory Error a NOVDRAM memory error was detected. The UCM is operating on all Engineering ROM defaults for all setup parameters. Check all I setup parameters and continue to run chiller. Replace the Chiller Module as soon as a replacement is available.
1AE	Low Diff. Pressure - Circuit 1	CMR	Compressor Energized	a. The fan control algorithm detected a low differential temperature/ pressure condition that existed for more than 180 contiguous seconds. The trip-point is 40 PSID.
1AF	Low Diff. Pressure - Circuit 2	CMR	Compressor Energized	Same as diagnostic 1AE.
1b2	Severe Phase Unbalance - Compressor A	CMR	All Running Modes	a. A 30% Phase Unbalance diagnostic has been detected. The 15% Phase Unbalance criteria has been defeated. Items to check are the Current Transformer Part Numbers (they should all match), The Current Transformer resistances, line voltage phase balance, all power wiring connections, the contactor pole faces, and the motor.
1b3	Severe Phase Unbalance - Compressor B	CMR	All Running Modes	Same as diagnostic 1b2.
1b4	Severe Phase Unbalance - Compressor C	CMR	All Running Modes	Same as diagnostic 1b2.
1b5	Severe Phase Unbalance - Compressor D	CMR	All Running Modes	Same as diagnostic 1b2.
1b6	Overload Setting - Compressor A	IFW	All	a. The CPM NovRam Based overload setting did not agree with the MCSP Dip Switch overload setting for 30 contiguous seconds. The affected MCSP shall use the minimum (00000 binary, 00 decimal) overload setting as a default until the UCM is reset when this diagnostic occurs.
1b8	Overload Setting - Compressor C	IFW	All	Same as diagnostic 1b6.
1b9	Overload Setting - Compressor D	IFW	All	Same as diagnostic 1b6.
1bA	Phase Unbalance - Compressor A	CMR	All Running Modes	a. A 15% phase unbalance has been detected. Menu Item "47" is enabled.
1bb	Phase Unbalance - Compressor B	CMR	All Running Modes	Same as diagnostic 1bA.
1bC	Phase Unbalance - Compressor C	CMR	All Running Modes	Same as diagnostic 1bA.
1bd	Phase Unbalance - Compressor D	CMR	All Running Modes	Same as diagnostic 1bA.

**Table 18
Diagnostics and Troubleshooting Chart (Continued)**

CODE	DIAGNOSTIC DESCRIPTION	TYPE	DIAG. ACTIVE MODES	CAUSE
1bE	Winding Temp.- Compressor A	CMR	All	<ul style="list-style-type: none"> a. The motor winding temperature thermostat opened; nominally 221 F. b. The motor temperature thermostat or wiring is open. c. Time to trip from input open to compressor shutdown shall be 0.5 to 2.0 seconds.
1bF	Winding Temp.- Compressor B	CMR	All	Same as diagnostic 1bE.
1C0	Winding Temp.- Compressor C	CMR	All	Same as diagnostic 1bE.
1C1	Winding Temp.- Compressor D	CMR	All	Same as diagnostic 1bE.
1C2	Discharge Temp.- Compressor A	CMR	All	<ul style="list-style-type: none"> a. The discharge temperature exceeded the trip value of 275 F. b. The discharge temperature PTC or wiring is open. <p>Note: on units built in 1992 and later, the discharge temp sensor will not be present.</p>
1C3	Discharge Temp. - Compressor B	CMR	All	Same as diagnostic 1C2.
1C4	Discharge Temp. - Compressor C	CMR	All	Same as diagnostic 1C2.
1C5	Discharge Temp. - Compressor D	CMR	All	Same as diagnostic 1C2.
1C6	High Diff. Pressure - Circuit 1	CMR	Compressor Energized	<ul style="list-style-type: none"> a. The difference between the condenser pressure and the evaporator pressure exceeded 350 PSID for 0.8 to 5.0 seconds. 320 PSID must hold, 320+ to trip for 1 hour.
1C7	High Diff. Pressure - Circuit 2	CMR	Compressor Energized	Same as diagnostic 1C6.
1d1	Memory Error Type II	IFW	All	<ul style="list-style-type: none"> a. A Shadow RAM memory error was detected. The UCM is operating on all last valid values (pulled from NOVRAM) for all setup parameters. No setup parameter changes were pending to be loaded into NOVRAM, a complete recovery of all setup parameters was made and there is no need to check unit setup parameters. Compressor starts and hours were lost for not more than the last 24 hours. This is expected to be an isolated event and repair or replacement is not required.
1d2	Memory Error Type III	IFW	All	<ul style="list-style-type: none"> a. A Shadow RAM memory error was detected. The UCM is operating on all last valid values (pulled from NOVRAM) for all setup parameters. Setup parameter changes less than 24 hours old pending to be loaded into NOVRAM were lost. Check all setup parameters made in last 24 hours. Compressor starts and hours were lost for not more than 24 hours. This is expected to be an isolated event and repair or replacement is not required.

Table 18
Diagnostics and Troubleshooting Chart (Continued)

CODE	DIAGNOSTIC DESCRIPTION	TYPE	DIAG. ACTIVE MODES	CAUSE
1d3	Comp. Suction Temp. Sensor - Circuit 1	CMR	All	a . Open or Short in sensor electrical circuitry.
1d4	Comp. Suction Temp. Sensor - Circuit 2	CMR	All	a. Open or Short in sensor electrical circuitry.
1d7	Phase Reversal Protection Lost - Compressor A	CMR	Compressor Energized to To Transition Command	a. The phase reversal protection Compressor A has become inoperative. The phase rotation protection system failed to detect two in a row of one of the four phase circuit states; Phase reversal, Phase Rotation OK, Phase A lost, Phase B lost.
1d8	Phase Reversal Protection Lost - Compressor B	CMR	Compressor Energized to Transition Command	Same as diagnostic 1d7.
1d9	Phase Reversal Protection Lost - Compressor C	CMR	Compressor Energized to Transition Command	Same as diagnostic 1d7.
1dA	Phase Reversal Protection Lost - Compressor D	CMR	Compressor Energized to Transition Command	Same as diagnostic 1d7.
1db	Slaved EXV Elec. Drive Circuit - Refrigerant Circuit I	CMR	On Demand and	a. Wiring between the EXV and the UCM Pre-Start is "Open". Check the connector for proper termination. b. EXV motor is faulty. c. EXV drive circuits on Module 1U3 are faulty
1dC	Slaved EXV Elec. Drive Circuit Refrigerant Circuit 2	CMR	On Demand and Pre-Start	Same as diagnostic 1db. Also refer to diagnostics 1A9 and 1AA.
412	1U1 Indicating 1U2 Communications	IFW	All	The 1U1 Module has detected a loss of inter-processor communications from the 1U2 Module.
413	1U1 Indicating 1U3 Communications	MMR	All	The 1U1 Module has detected a loss of inter-processor communications from the 1U3 Module.
414	1U1 Indicating 1U4 Communications	CMR	All	The 1U1 Module has detected a loss of inter-processor communications from the 1U4 Module.
415	1U1 Indicating 1U5 Communications	CMR	All	The 1U1 Module has detected a loss of inter-processor communications from the 1U5 Module.
416	1U1 Indicating 1U6 Communications	CMR	All	The 1U1 Module has detected a loss of inter-processor communications from the 1U6 Module.
417	1U1 Indicating 1U7 Communications	CMR	All	The 1U1 Module has detected a loss of inter-processor communications from the 1U7 Module.
418	1U1 Indicating 1U8 Communications	CMR	All	The 1U1 Module has detected a loss of inter-processor communications from the 1U8 Module.
431	1U3 Indicating 1U1 Communications	MMR	All	The 1U3 Module has detected a loss of inter-processor communications from the 1U1 Module.
434	1U3 Indicating 1U4 communications	CMR	All	The 1U3 Module has detected a loss of inter-processor communications from the 1U4 Module.

Table 18
Diagnostics and Troubleshooting Chart (Continued)

CODE	DIAGNOSTIC DESCRIPTION	TYPE	DIAG. ACTIVE MODES	CAUSE
435	1U3 Indicating 1U5 Communications	CMR	All	The 1U3 Module has detected a loss of inter-processor communications from the 1U5 Module.
436	1U3 Indicating 1U6 Communications	CMR	All	The 1U3 Module has detected a loss of inter-processor communications from the 1U6 Module.
437	1U3 Indicating 1U7 Communications.	CMR	All	The 1U3 Module has detected a loss of inter-processor communications from the 1U7 Module.
441	1U4 Indicating 1U1 Communications	CMR	All	The 1U4 Module has detected a loss of inter-processor communications from the 1U1 Module.
443	1U4 Indicating 1U3 Communications	CMR	All	The 1U4 Module has detected a loss of inter-processor communications from the 1U3 Module.
445	1U4 Indicating 1U5 Communications .	CMR	All	The 1U4 Module has detected a loss of inter-processor communications from the 1U5 Module.
451	1U5 Indicating 1U1 Communications	CMR	All	The 1U5 Module has detected a loss of inter-processor communications from the 1U1 Module.
453	1U5 Indicating 1U3 Communications	CMR	All	The 1U5 Module has detected a loss of inter-processor communications from the 1U3 Module.
454	1U5 Indicating 1U4 Communications	CMR	All	The 1U5 Module has detected a loss of inter-processor communications from the 1U4 Module.
461	1U6 Indicating 1U1 Communications	CMR	All	The 1U6 Module has detected a loss of inter-processor communications from the 1U1 Module.
463	1U6 Indicating 1U3 Communications	CMR	All	The 1U6 Module has detected a loss of inter-processor communications from the 1U3 Module.
467	1U6 Indicating 1U7 Communications	CMR	All	The 1U6 Module has detected a loss of inter-processor communications from the 1U7 Module.
471	1U7 Indicating 1U1 Communications	CMR	All	The 1U7 Module has detected a loss of inter-processor communications from the 1U1 Module.
473	1U7 Indicating 1U3 Communications	CMR	All	The 1U7 Module has detected a loss of inter-processor communications from the 1U3 Module.
476	1U7 Indicating 1U6 Communications	CMR	All	The 1U7 Module has detected a loss of inter-processor communications from the 1U6 Module.

Table 18
Diagnostics and Troubleshooting Chart (Continued)

CODE	DIAGNOSTIC DESCRIPTION	TYPE	DIAG. ACTIVE MODES	CAUSE
481	1U8 Indicating 1U1 Communications	MMR	All	The 1U8 Module has detected a loss of inter-processor communications from the 1U1 Module.
483	1U8 Indicating 1U3 Communications	CMR*	All	The 1U8 Module has detected a loss of inter-processor communications from the 1U3 Module.
484	1U8 Indicating 1U4 Communications	CMR	All	The 1U8 Module has detected a loss of inter-processor communications from the 1U4 Module.
485	1U8 Indicating 1U5 Communications	CMR	All	The 1U8 Module has detected a loss of inter-processor communications from the 1U5 Module.
486	1U8 Indicating 1U6 Communications	CMR	All	The 1U8 Module has detected a loss of inter-processor communications from the 1U6 Module.
487	1U8 Indicating 1U7 Communications	CMR	All	The 1U8 Module has detected a loss of inter-processor communications from the 1U7 Module.

*In the event of this communication diagnostic, CMR(s) will be generated for the circuit(s) which are using the Slaved EXV (i.e. those circuits which are employing a parallel valve arrangement).



Pre-Start Checkout

General

When installation is complete, but prior to putting the unit into service, the following pre-start procedures must be reviewed and verified correct:

- [] Inspect all wiring connections to be sure they are clean and tight.

WARNING: Disconnect all electric power including remote disconnects before servicing' Failure to disconnect power before servicing can cause severe personal injury or death.

Caution: Check the tightness of all connections in the compressor power circuits (disconnects, terminal block, contactors, compressor junction box terminals, etc.). Loose connections can cause overheating at the connections and undervoltage conditions at the compressor motor.

- [] Verify that all refrigerant valves, as shown in Figure 37, are "OPEN".

Caution: Do not operate the unit with the compressor, oil discharge and liquid line service valves "CLOSED". Failure to have these "OPEN" may cause serious compressor damage.

- [] Check the power supply voltage to the unit at the main power fused disconnect switch. Voltage must be within the voltage utilization range, given in Table 10 and also stamped on the unit nameplate. Voltage imbalance must not exceed 2 percent. Refer to "Unit Voltage Imbalance", below.

WARNING: Disconnect all electric power including remote disconnects before servicing. Failure to disconnect power before servicing can cause severe personal injury or death.

- [] Check the unit power phasing to be sure that it has been installed in an "ABC" sequence. Refer to "Unit Voltage Phasing", below.

WARNING: It is imperative that L1 -L2-L3 in the starter be connected in the A-B-C phase sequence to prevent equipment damage due to reverse rotation.

- [] Check the condenser fans to be sure that they rotate freely in the fan openings and that each is securely attached to its fan motor shaft.

WARNING: Disconnect all electric power including remote disconnects before servicing. Failure to disconnect power before servicing can cause severe personal injury or death.

- [] Energize the compressor sump heaters by closing the unit main disconnects. If unit-mounted disconnects are used, they must also be closed. If the unit does not have the optional control power transformer, 115 VAC power must be field supplied to terminals 1TB3-1 AND 1TB3-2. The Chiller Switch must be in the STOP/RESET position.

Caution: The compressor sump heaters must be energized for a minimum of 24 hours prior to unit operation, to prevent compressor damage caused by liquid refrigerant in the compressor at start-up.

- [] Energize the evaporator and Domestic Water Heater heat tape.
- [] Fill the evaporator chilled water circuit. Refer to Table 1 for evaporator liquid capacities. Vent the system while it is being filled. Open the vent on the top of the evaporator during filling and close when filling is completed.

Customer Note

The use of improperly treated or untreated water in this equipment may result in scaling, erosion, corrosion, algae or slime. The services of a qualified water treatment specialist should be engaged to determine what treatment, if any, is advisable. The Trane Company warranty specifically excludes liability for corrosion, erosion or deterioration of Trane equipment. Trane assumes no responsibilities for the results of the use of untreated or improperly treated water, or saline or brackish water.

Caution: Do not used untreated or improperly treated water. Equipment damage may occur.

Caution: Do not fill the water systems unless the evaporator and Domestic Water Heater heat tapes have been energized.

- [] Close the fused-disconnect switch(es) that supplies power to the chilled water pump starter.
- [] Start the chilled water pump to begin circulation of the chilled water. Inspect all piping for leakage and make any necessary repairs.
- [] With chilled water circulating through the system, adjust water flow and check water pressure drop through the evaporator. Refer to Figure 23.
- [] Adjust the chilled water flow switch (if installed) for proper operation.
- [] Prove Chilled Water Pump Interlock and External Auto/Stop as described in Interconnecting Wiring: Chilled Water Pump Interlock and External Auto/Stop.

Caution: Chilled Water Pump Interlock and External Auto/Stop information must be adhered to or equipment damage may occur.

- [] Check and set, as required, all UCM Menu items.
- [] Stop the chilled water pump.

Unit Voltage Power Supply

Voltage to the unit must meet the criteria given in Table 10. Measure each leg of the supply voltage at the unit main power fused-disconnect. If the measured voltage on any leg is not within specified range, notify the supplier of the power and correct the situation before operating the unit.

Caution: Inadequate voltage to the unit can cause control components to malfunction and shorten the life of relay contact, compressor motors and contactors.

Unit Voltage Imbalance

Excessive voltage imbalance between the phases of a three-phase system can cause Motors to overheat and eventually fail. The maximum allowable imbalance is 2 percent. Voltage imbalance is determined using the following calculations:

$$\% \text{ Imbalance} = \frac{(V_x - V_{ave}) \times 100}{V_{ave}}$$

$$V_{ave} = (V_1 + V_2 + V_3)^{1/3}$$

V_x = phase with greatest difference from V_{ave} (without regard to sign)

For example, if the three measured voltages are 221, 230, and 227 volts, the average would be:

$$\frac{221 + 230 + 227}{3} = 226$$

The percentage of imbalance is then:

$$\frac{100 (221 - 226)}{226} = 2.2\%$$

This exceeds the maximum allowable (2%) by 0.2 percent.

Unit Voltage Phasing

It is important that proper rotation of the compressors be established before the unit is started. Proper motor rotation requires confirmation of the electrical phase sequence of the power supply. The motor is internally connected for clockwise rotation with the incoming power supply phased A, B, C.

Basically, voltages generated in each phase of a polyphase alternator or circuit are called phase voltages. In a three-phase circuit, three sine wave voltages are generated, differing in phase by 120 electrical degrees. The order in which the three voltages of a three-phase system succeed one another is called phase sequence or phase rotation. This is determined by the direction of rotation of the alternator. When rotation is clockwise phase sequence is usually called "ABC", when counterclockwise, "CBA".

This direction may be reversed outside the alternator by interchanging any two of the line wires. It is this possible interchange of wiring that makes a phase sequence indicator necessary if the operator is to quickly determine the phase rotation of the motor.

Proper compressor motor electrical phasing can be quickly determined and corrected before starting the unit. Use a quality instrument, such as the Associated Research Model 45 Phase Sequence Indicator shown in Figure 55, and follow this procedure.

⚠ WARNING
IT IS IMPERATIVE THAT L1-L2-L3 IN THE STARTER BE CONNECTED IN THE A-B-C PHASE SEQUENCE TO PREVENT EQUIPMENT DAMAGE DUE TO REVERSE ROTATION.

Figure 55
Associated Research Model 45
Phase Sequence Indicator

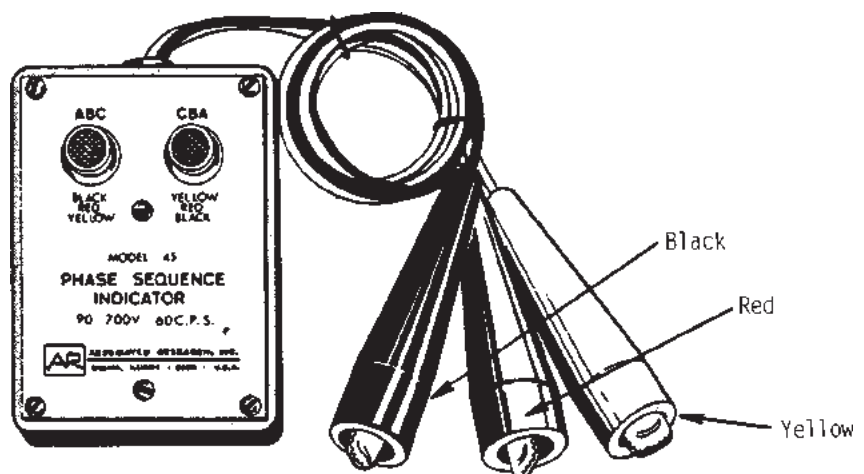

1. Turn the Chiller Switch on the UCM to the STOP/RESET position.
2. Open the electrical disconnect or circuit protection switch that provides line power to the line power terminal block(s) in the starter panel (or to the unit-mounted disconnect).
3. Connect the phase sequence indicator leads to the line power terminal block, as follows:

Phase Seq. Lead	Terminal
Black (Phase A)	L1
Red (Phase B)	L2
Yellow (Phase C)	L3
4. Turn power on by closing the unit supply power fused- disconnect switch.
5. Read the phase sequence on the indicator. The "ABC" LED on the face of the phase indicator will glow if phase is "ABC".

WARNING: To prevent injury or death due to electrocution, take extreme care when performing service procedures with electrical power energized.

6. If the "CBA" indicator glows instead, open the unit main power disconnect and switch two line leads on the line power terminal block(s) (or the unit mounted disconnect). Reclose the main power disconnect and recheck the phasing.

Caution: Do not interchange any load leads that are from the unit contactors or the motor terminals.

7. Reopen the unit disconnect and disconnect the phase indicator.

Water System Flow Rates

Establish a balanced chilled water flow through the evaporator. The flow rates should fall between the minimum and maximum values given in Table 1. Chilled water flow rates below the minimum values will result in laminar flow, which reduces heat transfer and causes either loss of EXV control or repeated nuisance, low temperature cutouts. Flow rates that are too high can cause tube erosion and damage to the tube supports and baffles in the evaporator.

Caution: Once the evaporator and Domestic Water Heater (optional) are filled with water, the heat tapes must be energized to protect the evaporator from freezing and bursting if the outdoor air temperature drops below freezing.

Water System Pressure Drop

Measure chilled water pressure drop through the evaporator at the field-installed pressure taps on the system water piping. See Figure 22. Use the same gauge for each measurement. Do not include valves, strainers fittings in the pressure drop readings.

Measure the water pressure drop through the Domestic Water Heater at the field installed vent and drain connections. See Figure 24. Use the same gauge for each measurement. Do not include valves, strainers, fittings in pressure drop readings.

Pressure drop readings should be approximately those shown in the Pressure Drop Charts, Figure 23 for the evaporator and Figure 25 for the Domestic Water Heater (optional).

UCM Set-up

Refer to "Menu Function Descriptions and Selection" for instruction on the set-up of the UCM.

Start-Up Procedures

General

If the pre-start checkout, as discussed above, has been completed, the unit is ready to start. UCM controls are shown in Figure 51 and UCM Sequence of Operation is shown in Figures 56 and 57. Complete each step, in sequence, as follows:

- [] Move the Chiller Switch on the UCM to the STOP/RESET position.
- [] As necessary, adjust the setpoint values in the UCM menus, as described in “Menu Function Descriptions and Selections”.
- [] Close the fused-disconnect switch for the chilled water pump. Energize the pump to start chilled water circulation.
- [] Check the service valves on the discharge line, suction line, oil line and liquid line for each circuit. These valves must be open (backseated) before starting the compressors.

Caution: To prevent compressor damage, do not operate the unit until all refrigerant and oil line service valves are opened.

- [] Energize the compressor sump heaters, if not already energized. Also close the unit-mounted disconnect, if used.

Caution: The compressor sump heaters must be energized for a minimum of 24 hours prior to unit operation, to prevent compressor damage caused by liquid refrigerant in the compressor at start-up.

- [] Verify that the evaporator heat tape is energized.
- [] Verify that the chilled water pump runs for one minute after the chiller is commanded to stop (for normal chilled water systems). See page
- [] Move the Chiller Switch to AUTO LOCAL. If the chiller control 1 U 1 calls for cooling and all safety interlocks are closed, the unit will start. The compressor(s) will load and unload in response to the temperature of the leaving chilled water temperature.

If optional low-ambient is installed, outside air temperature must be above the minimum starting ambients, as shown in Table 1, for continued unit operation. Use Table 1 to determine proper setpoints for the optional low ambient lockout setpoint, if used. Also refer to the wiring diagrams in Figures 34 thru 36.

Once the system has been operating for approximately 30 minutes and has become stabilized, complete the start-up procedures, as follows:

- [] Check the evaporator refrigerant pressure (23) and the condenser refrigerant pressure (25) in Menu 2 on the UCM. The pressures are referenced to sea level (14.6960 psia)
- [] Check the liquid line sight glasses. The refrigerant flow past the sight glasses should be clear. Bubbles in the refrigerant indicate either low refrigerant charge or excessive pressure drop in the liquid line. A restriction in the line can sometimes be identified by a noticeable temperature differential between the two sides of the restriction. Frost may often form on the line at this point. Proper refrigerant charges are shown in Table 1.

Caution: A clear sight glass alone does not mean that the system is properly charged. Also check system superheat, subcooling, and unit operating pressures.

- [] Measure the system superheat. Refer to “System Superheat, below.
- [] Measure the system subcooling. Refer to “System Subcooling”, below.
- [] A shortage of refrigerant is indicated if operating pressures are low and subcooling is also low. If the operating pressures, sight glass, superheat and subcooling readings indicate a refrigerant shortage, gas-charge refrigerant into each circuit, as required. With the unit running, add refrigerant vapor by connecting the charging line to the suction service valve and charging through the backseat port until operating conditions become normal.

Caution: If both suction and discharge pressures are low but subcooling is normal, a problem other than refrigerant shortage exists. Do not add refrigerant, as this may result in overcharging the circuit.

Caution: Use only refrigerants specified on the unit nameplate, to prevent compressor damage and insure full system capacity.

- [] If operating conditions indicate a refrigerant overcharge, remove refrigerant at the liquid line service valve. Allow refrigerant to escape slowly, to minimize oil loss. Do not discharge refrigerant into the atmosphere.

WARNING: Do not allow refrigerant to directly contact skin or injury from frostbite may result.

System Superheat

Normal superheat for each circuit is approximately 8 F at full operating load. Superheat temperature can be expected to be moving around the 8 F setpoint when the chiller is pulling down, the compressor slide valve is being modulated, or the fans are staging on either the same or opposite circuits. Superheat can be expected to settle out at approximately 8 F when the above items stabilize.

System Subcooling

Normal subcooling for each circuit ranges from 11 F to 20 F, depending on the unit. If subcooling for either circuit does not approximate these figures, check the superheat for the circuit and adjust, if required. If superheat is normal but subcooling is not, contact a qualified service technician.

Figure 56
Unit Sequence of Operation - RTAA 240 to 400 Tons

<p>⚠ WARNING</p> <p>HAZARDOUS VOLTAGE!</p> <p>DISCONNECT ALL ELECTRIC POWER INCLUDING REMOTE DISCONNECTS BEFORE SERVICING.</p> <p>FAILURE TO DISCONNECT POWER BEFORE SERVICING CAN CAUSE SEVERE PERSONAL INJURY OR DEATH.</p>	<p>⚠ AVERTISSEMENT</p> <p>VOLTAGE HASARDEUX!</p> <p>DECONNECTEZ TOUTES LES SOURCES ELECTRIQUES INCLUANT LES DISJONCTEURS SITES A DISTANCE AVANT D'EFFECTUER L'ENTRETIEN.</p> <p>FAUTE DE DECONNECTER LA SOURCE ELECTRIQUE AVANT D'EFFECTUER L'ENTRETIEN PEUT ENTRAINDER DES BLESSURES CORPORELLES SEVERES OU LA MORT.</p>
<p>IMPORTANT</p> <p>USE COPPER CONDUCTORS ONLY TO PREVENT EQUIPMENT DAMAGE. UNIT TERMINALS ARE NOT DESIGNED TO ACCEPT ANY OTHER WIRING.</p>	

NOTES:

- Ⓔ81 MAX & MIN DIAGNOSTICS WILL EFFECT AN IMMEDIATE SHUTDOWN; 75 RUN UNLOAD WILL BE IGNORED.
- Ⓔ82 UNLOAD SOLENOID ENERGIZED FOR 2 MINUTES WHEN POWERED UP IN EITHER STOP/RESET OR AUTO.
- Ⓔ83 EACH CPRSR GOES THROUGH THESE STEPS TO START AND STOP. STEPS ARE SHOWN ONLY FOR FIRST CPRSR "ON" AND LAST CPRSR "OFF".

UNIT SEQUENCE OF OPERATION

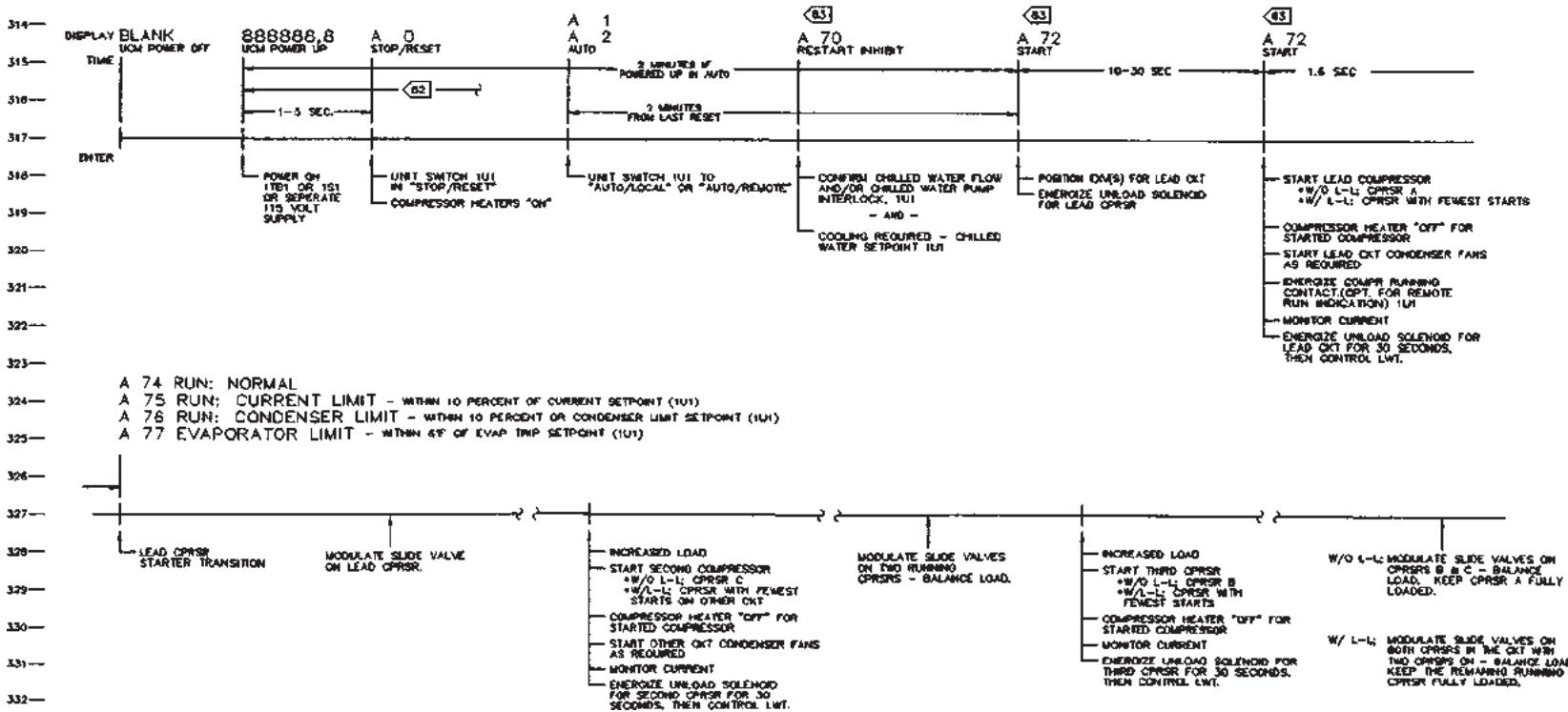

(Continued on Next Page)

(Continued from Previous Page)

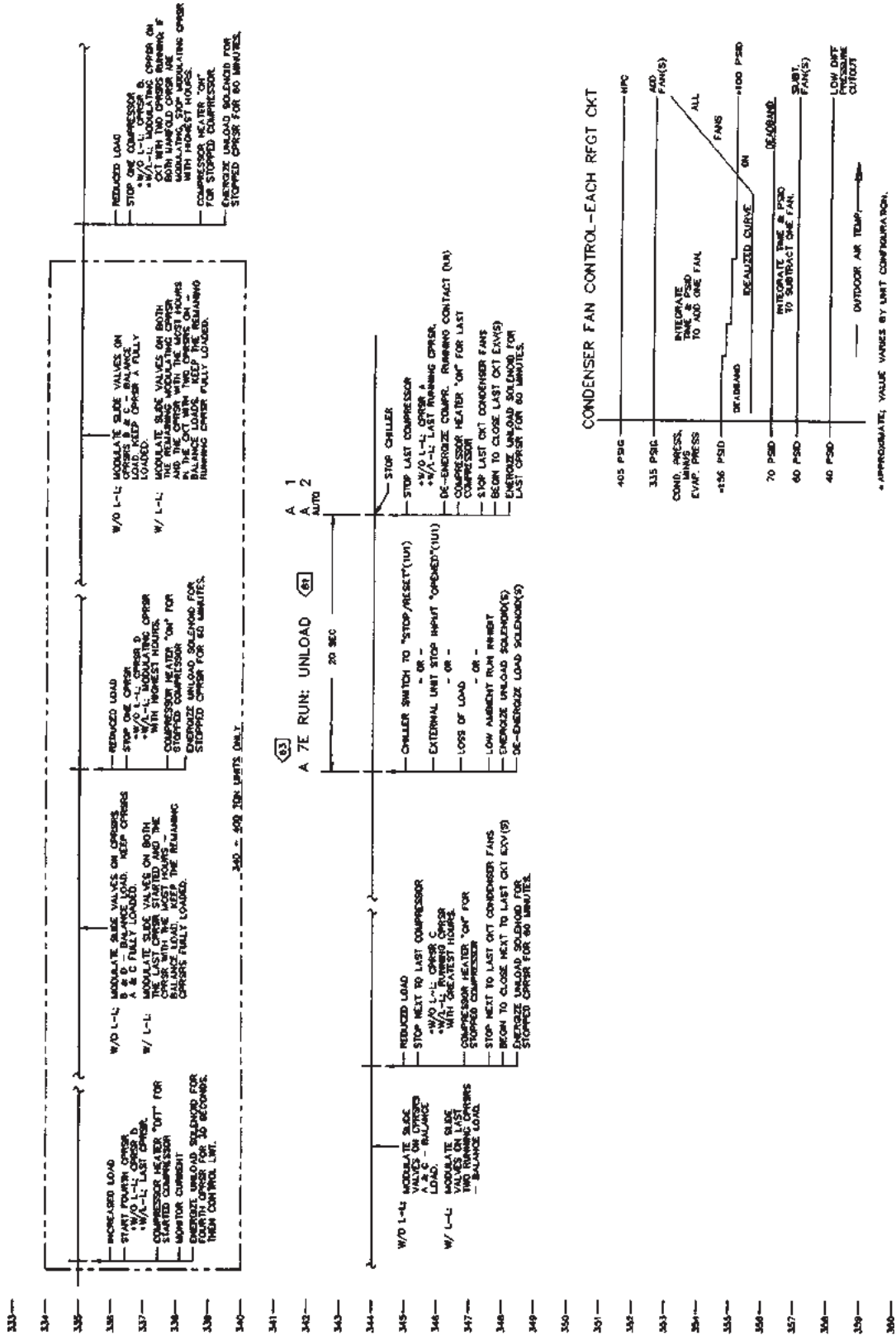

2307-1566C

Figure 57
Unit Sequence of Operation - RTAA 130 to 200 Tons

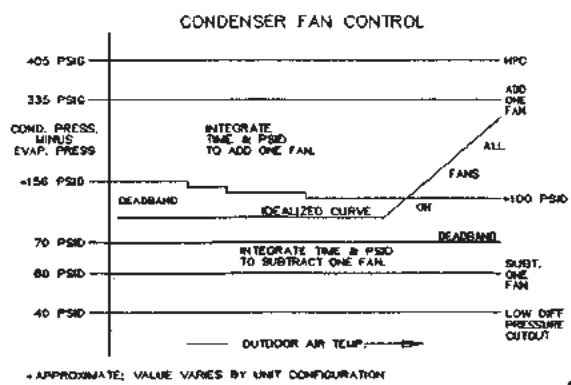
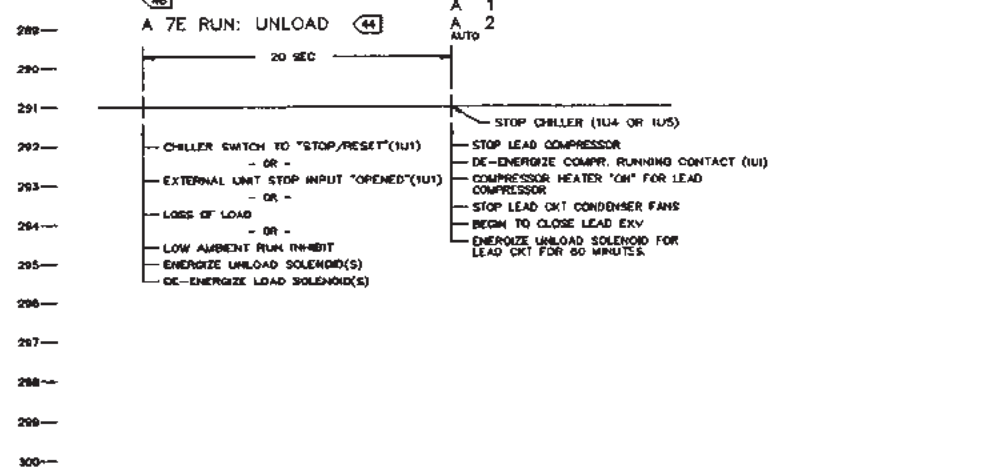
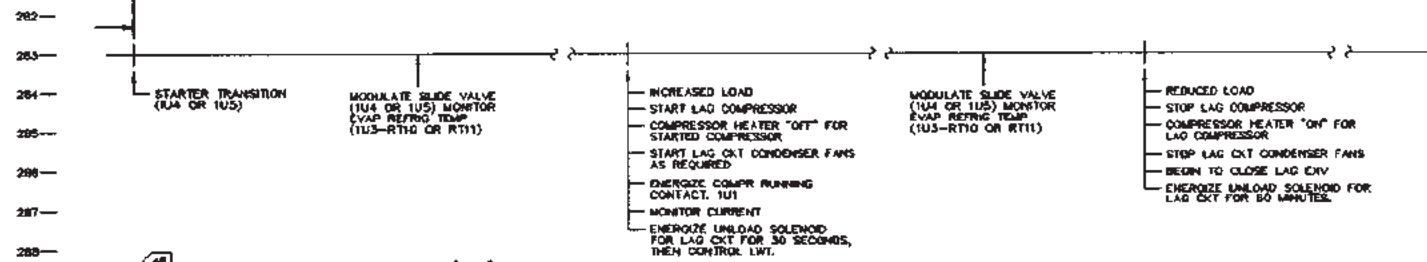
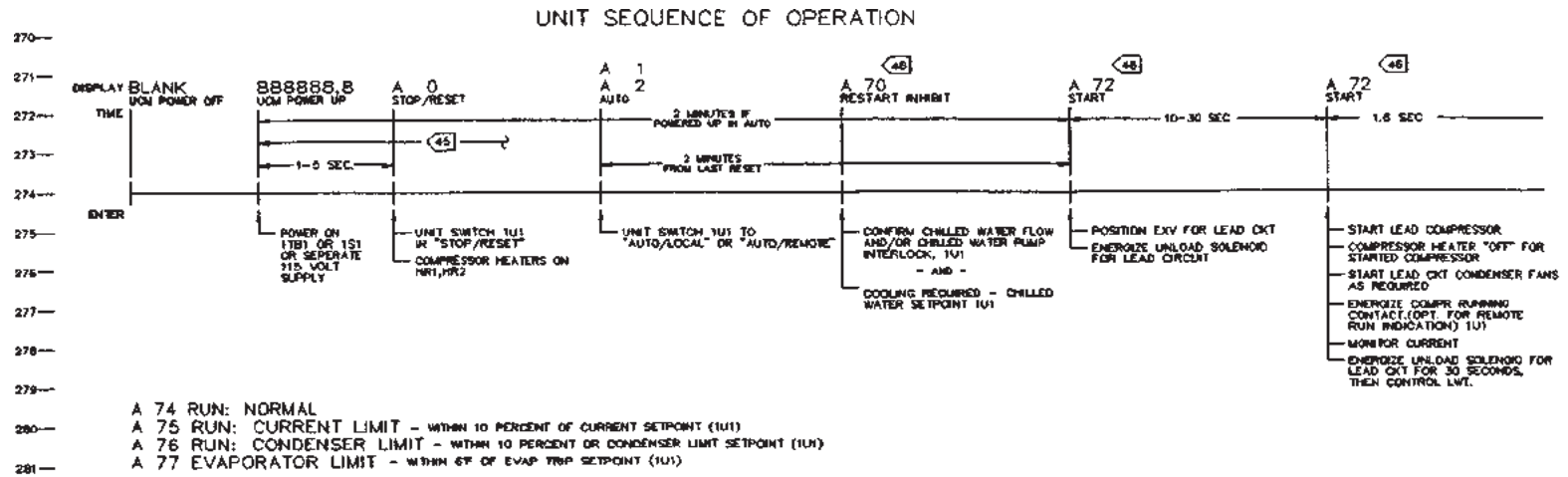

Unit Shutdown Procedures

Temporary Shutdown and Restart

To shut the unit down for a short time, use the following procedure:

1. Move the Chiller Switch to STOP/RESET. The compressors will continue to operate and, after unloading for 20 seconds, will stop when the compressor contactors de-energize. The condenser fans will be de-energized at this time.
2. The unit disconnect switch and unit mounted disconnect (if installed) should remain closed to keep the compressor sump heaters energized.
3. Maintain power to keep the evaporator and Domestic Water Heater heat tape(s) energized.
4. Stop the chilled water circulation by turning off the chilled water pump.

To restart the unit after a temporary shutdown, restart the chilled water pump and move the Chiller Switch to either of the AUTO positions. The unit will start normally, provided the following conditions exist:

1. The UCM must receive a call for cooling and the differential- to-start must be above the setpoint.
2. All system operating interlocks and safety circuits must be satisfied.

Extended Shutdown Procedure

The following procedure is to be followed if the system is to be taken out of service for an extended period of time, e.g. seasonal shutdown:

1. Test the condenser and high-side piping for refrigerant leakage.
2. Open the electrical disconnect switches for the chilled water pump. Lock the switch in the "OPEN" position.

Caution: Lock the chilled water pump disconnect open to prevent pump damage.

3. Close all chilled water supply valves. Drain the chilled water from the evaporator. If the unit will be exposed to freezing ambient conditions, flush the evaporator with an antifreeze solution and energize the evaporator heat tape.

Caution: To prevent damage to the evaporator by freezing, flush the evaporator with an antifreeze solution and energize the evaporator heat tape.

4. Drain the Domestic Water Heater and any exposed system piping to prevent the possibility of freeze-up. Use the pressure tap on the water outlet to force compressed air through the water coils of the unit and assure that no water blocks any of the tubes. Be certain that the drain valve on the water inlet is open before applying compressed air to the water coils. Energize the Domestic Water Heater heat tape.

Caution: To prevent damage to the Domestic Water Heater by freezing, blow out water from coils and energize the Domestic Water Heater heat tape.

5. Open the unit main electrical disconnect and unit-mounted disconnect (if installed) and lock on the "OPEN" position. If optional control power transformer is not installed, open and lock the 115 V disconnect.

Caution: Lock the disconnects on the "OPEN" position to prevent accidental start-up and damage to the system when it has been setup for extended shutdown.

6. At least every three months (quarterly), check the pressure in the unit to verify that the refrigerant charge is intact.

System Restart After Extended Shutdown.

Follow the procedures below to restart the unit after extended shutdown:

1. Verify that the liquid line service valves, oil line, compressor discharge service valves and suction service valves (if installed) are open (backseated).

Caution: To prevent damage to the compressor, be sure that all refrigerant valves are open before starting the unit.

2. Close the main disconnect and unit mounted disconnect (if installed) to energize the compressor sump heaters. If the optional control transformer is not installed, it will be necessary to close the disconnect for 115 VAC power to 1TB3-1 and 1TB3-2.

Caution: The compressor sump heaters must be energized for a minimum of 24 hours prior to unit operation, to prevent compressor damage caused by liquid refrigerant in the compressor at start-up.

3. Maintain power to the evaporator heat tape connections.
4. Check the oil separator oil level. See "Oil Separator Level Check".
5. Fill the evaporator chilled water circuit. Refer to Table I for evaporator liquid capacities. Vent the system while it is being filled. Open the vent on the top of the evaporator during filling and close when filling is completed.

Caution: Do not use untreated or improperly treated water. Equipment damage may occur.

6. Close the fused-disconnect switch that provides power to the chilled water pump.
7. Start the chilled water pump and, while chilled water is circulating, inspect all piping for leakage. Make any necessary repairs before starting the unit.
8. While the chilled water is circulating, adjust the chilled water flow and check the chilled water pressure drop through the evaporator. Refer to "Water System Flow Rates" and "Water System Pressure Drop".
9. Adjust the flow switch on the evaporator piping (if installed) for proper operation.
10. Stop the chilled water pump. The unit is now ready for start-up as described in "Start-Up Procedures".

Periodic Maintenance

General

Perform all maintenance procedures and inspections at the recommended intervals. This will prolong the life of the equipment and minimize the possibility of costly failures.

Use an "Operator's Log", such as that shown in Figure 58, to record an operating history for the unit. The log serves as a valuable diagnostic tool for service personnel. By observing trends in operating conditions, an operator can anticipate and prevent problem situations before they occur.

If the unit does not operate properly during maintenance inspections, refer to "Diagnostics and Troubleshooting".

**Figure 58
Operator's Log**

RTAA 130 TO 400 TON "C" DESIGN SEQUENCE AIR COOLED SERIES R TEST LOG

Job Name				Elevation Above Sea Level				Menu #		Value						
Job Location				Ft.				i0								
Unit Model No.				S.O. No.				11								
Unit Serial No.				Nameplate Volt				Ship Date		12						
Comp A	Model No.		Nameplate RLA		Overload	ON	1 2 3 4 5				13					
	Serial No.				Dipswitch	OFF	1 2 3 4 5				15*					
Comp B	Model No.		Nameplate RLA		Overload	ON	1 2 3 4 5				16*					
	Serial No.				Dipswitch	OFF	1 2 3 4 5				1A					
Comp C	Model No.		Nameplate RLA		Overload	ON	1 2 3 4 5				30*					
	Serial No.				Dipswitch	OFF	1 2 3 4 5				31*					
Comp D	Model No.		Nameplate RLA		Overload	ON	1 2 3 4 5				32*					
	Serial No.				Dipswitch	OFF	1 2 3 4 5				33*					
Evap H ₂ O		Design PSID		Actual PSID		Fan Motor RLA				34*						
Pressure Drop		Design GPM		Actual GPM		Heat Tape Volt				35*						
Circuit				1		2		1		2		36*				
Compressor				A	B	C	D	A	B	C	D	A	B	C	D	37*
Unit Voltage		P H A S E	A - B												38*	
			A - C												39*	
			B - C												3A*	
A	Unit Operating Code													3b		
b	Last Diagnostic													40		
E	Evap H ₂ O Ent F													41		
F	Evap H ₂ O Lvg F													42		
14*	Outdoor Air Temp.													43		
20	Compressor Mode													44		
21	Compressor Suction F													45		
22	Saturated Evap F													46		
23	Evap. Ref. Press. PSIG													47		
24	Saturated Cond F													48		
25	Cond. Ref. Press. PSIG													49		
27	Compressor % RLA													4A		
28*	% Line Volts													4b		
29*	Compressor Starts													4C		
2A*	Compressor Hours													4d		
Comments											4E					
											4F					
											50					
											51					
											52					
											53					
											54					
											55					
											56					
											57					
											58					
											59					
											5A					
											5b					
											5C					
											*Option					
Date				Svc Tech				Owner								

Refrigerant Emission Control

Evidence from environmental scientists indicates that the ozone in our upper atmosphere is being reduced, due to the release of CFC fully halogenated compounds.

The Trane Company encourages every effort to eliminate, if possible, or vigorously reduce the emission of CFC, HCFC and HFC refrigerants into the atmosphere that result from installation, operation, routine maintenance, or major services on this equipment. Always act in a responsible manner to conserve refrigerants for continued use, even when acceptable alternatives are available.

Conservation and emission reduction can be accomplished by following recommended Trane operation, maintenance and service procedures, with specific attention to the following:

1. Refrigerant used in any type of air conditioning or refrigerating equipment should be recovered for reuse, recovered and/or recycled for reuse, reprocessed (reclaimed), or properly destroyed, whenever it is removed from equipment. Never release refrigerant into the atmosphere.
2. Always determine possible recycle or reclaim requirements of the recovered refrigerant before beginning recovery by any method. Questions about recovered refrigerants and acceptable refrigerant quality standards are addressed in ARI Standard 700.
3. Use approved containment vessels and safety standards. Comply with all applicable transportation standards when shipping refrigerant containers.
4. To minimize emissions while recovering refrigerant, use recycling equipment. Always attempt to use methods which will pull the lowest possible vacuum while recovering and condensing refrigerant into containment.
5. When leak checking with trace refrigerant and nitrogen, use HCFC-22 (R-22), rather than CFC-12 (R-12) or any other fully halogenated refrigerants. Be aware of any new leak test methods which eliminate refrigerant as a trace gas.

6. When cleaning system components or parts, avoid using CFC-11 (R-11) or CFC-113 (R-113). Refrigeration system

cleanup methods which use filters and dryers are preferred. Do not use solvents which have ozone depletion factors. Properly dispose of used materials.

7. Take extra care to properly maintain all service equipment that directly supports refrigeration service work, such as gauges, hoses, vacuum pumps and recycling equipment.
8. Stay aware of unit enhancements, conversion refrigerants, compatible parts and manufacturer's recommendations which will reduce refrigerant emissions and increase equipment operating efficiencies. Follow manufacturer's specific guidelines for conversion of existing systems.
9. In order to assist in reducing power generation emissions, always attempt to improve equipment performance with improved maintenance and operations that will help conserve energy resources.

Weekly Maintenance

After the unit has been operating for approximately 30 minutes and the system has stabilized, check the operating conditions and complete the procedures below:

- [] Check the evaporator refrigerant pressure (23) and the condenser refrigerant pressure (25) in Menu 2 on the UCM. The pressures are referenced to sea level (114.6960 psia).
- [] Check the liquid line sight glasses. The refrigerant flow past the sight glasses should be clear. Bubbles in the refrigerant indicate either low refrigerant charge or excessive pressure drop in the liquid line. A restriction in the line can sometimes be identified by a noticeable temperature differential between the two sides of the restriction. Frost may often form on the line at this point. Proper refrigerant charges are shown on Table 1.

Caution: A clear sight glass alone does not mean that the system properly charged. Also check system superheat, subcooling, and unit operating pressures.

[] If operating pressures and sight glass conditions seem to indicate refrigerant shortage, measure the system superheat and system subcooling. Refer to "System Superheat" and "System Subcooling".

[] If operating conditions indicate a refrigerant overcharge, remove refrigerant at the liquid line service valve. Allow refrigerant to escape slowly, to minimize oil loss. Do not discharge refrigerant into the atmosphere.

WARNING: Do not allow refrigerant to directly contact skin or injury from frostbite may result.

[] Inspect the entire system for unusual conditions and inspect the condenser coils for dirt and debris. If the coils are dirty, refer to "Coil Cleaning".

Monthly Maintenance

[] Perform all weekly maintenance procedures.

[] Measure and record the system superheat. Refer to "System Superheat".

[] Measure and record the system subcooling. Refer to "System Subcooling".

[] Manually rotate condenser fans to insure proper clearance on the fan openings.

WARNING: Position all electrical disconnects in the "OPEN" position and lock them, to prevent injury or death due to electrical shock.

Annual Maintenance

[] Perform all weekly and monthly maintenance procedures.

[] Check the oil level and refrigerant charge. Refer to "Maintenance Procedures".

[] Have a qualified laboratory perform a compressor oil analysis to determine system moisture content and acid level. This analysis is a valuable diagnostic tool.

[] Contact a qualified service organization to leak test the chiller, to check operating and safety controls, and to inspect electrical components for deficiencies.

[] Inspect all piping components for leakage and damage. Clean out any inline strainers.

[] Clean and repaint any areas that show signs of corrosion.

[] Clean the condenser coils. Refer to "Coil Cleaning".

[] Clean the Domestic Water Heater. Refer to Domestic Water Heater tube cleaning procedure.

WARNING: Position all electrical disconnects in the "OPEN" position and lock them, to prevent injury or death due to electrical shock.

[] Clean the condenser fans. Check the fan assemblies for proper clearance in the fan openings and for motor shaft misalignment, abnormal endplay, vibration and noise.

WARNING: Position all electrical disconnects in the "OPEN" position and lock them, to prevent injury or death due to electrical shock.

Maintenance

General

This section describes specific maintenance procedures which must be performed as a part of the normal maintenance program for this unit. Be certain that electrical power to the unit is disconnected before performing these procedures.

WARNING: Position all electrical disconnects in the "OPEN" position and lock them, to prevent injury or death due to electrical shock.

Coil Cleaning

Clean the condenser coils at least once each year, or more frequently if the unit is located in a "dirty" environment. This will maintain proper unit operating efficiencies. Follow the detergent manufacturer's instructions as closely as possible to avoid damage to the coils.

To clean the coils, use a soft brush and a sprayer, either the garden, pump-up type or a high-pressure type. A high-quality detergent, such as "Trane Coil Cleaner, CHM-0002" is recommended for both standard and "Blue-Fin" coils.

Note: If the detergent mixture is strongly alkaline (pH value greater than 8.5), an inhibitor must be added.

Chemically Cleaning The Evaporator

The chilled water system is a closed-loop and therefore should not accumulate scale or sludge. If the chiller becomes fouled, first attempt to dislodge the material by backflushing the system. If unsuccessful after several attempts, chemically clean the evaporator.

Caution: Do not use an acid type cleaning agent that will damage steel, galvanized steel, polypropylene, or internal copper components.

With this information, water treatment firms will be able to recommend a suitable chemical for use in this system.

A typical configuration for chemical cleaning is shown in Figure 59. The supplier of the cleaning chemicals must provide or approve:

- All of the materials used in this configuration

- The amount of chemicals used

- The length of time the chemicals are used

- Any safety precautions and handling instructions

Domestic Water Heater – Tube Cleaning

The water tubes may be mechanically cleaned with a wire brush. This can be done by isolating the water supply to the Domestic Water Heater, relieving the water pressure, and removing the access plugs at the rear of the unit. Once the tubes have been brushed and scale has been loosened, flush the water tubes with fresh water, reinstall the access plugs and return to service. The circulator should be shut off during this operation and all air must be bled from the water circuit when returning the unit to operation. Be certain to use an approved pipe sealant on the threaded access plugs when reinstalling to prevent water leaks.

Figure 59
Chemical Cleaning Configuration

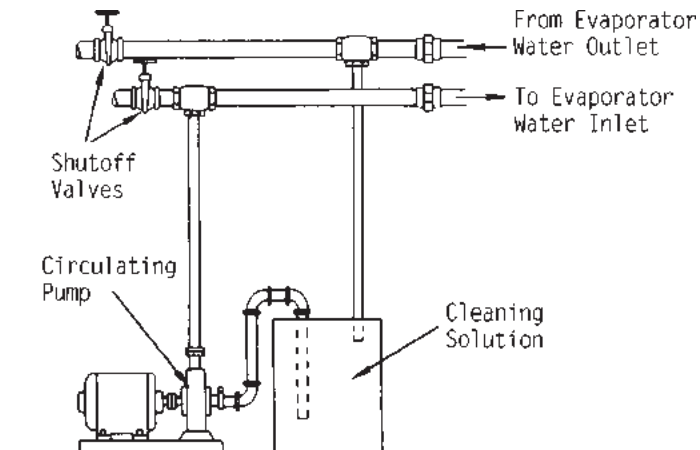

Water Treatment

The use of untreated or improperly treated water in the unit may result in the formation of scale, algae, or slime. It may also cause erosion or corrosion. It is recommended that a qualified water treatment specialist provide recommendations for proper water treatment. The Trane Company assumes no responsibility for equipment failure caused by the use of untreated or improperly treated water.

Oil Separator Level Check

Follow the steps listed below and refer to the notes listed in Figure 60.

1. Turn off the unit,
2. Attach the hoses and sight glass to the oil separator charging Schrader valve and the compressor discharge line Schrader valve, as shown in Figure 60. Purge to remove non-condensibles.

It is advisable to use Schrader quickcoupler isolation valves at the ends of the hoses. These will aid in the installation and removal of the hoses and minimize oil and refrigerant spray.

3. After the unit has been off for 10 minutes, move the sight glass up and down until the level can be seen.
4. After the level has been determined, remove the sight glass and hoses.

Note: Routine changing of the oil or the oil filter is not recommended. The oil filter is oversized for this application and should not require replacement.

The oil and filter should be replaced only if analysis reveals that the oil is contaminated. Oil type and system capacities are shown in Table 1.

Figure 60
System Oil Level Specifications

Insure that the apex of the line above the sight glass is as high as possible, to eliminate liquid traps which can give erroneous readings.

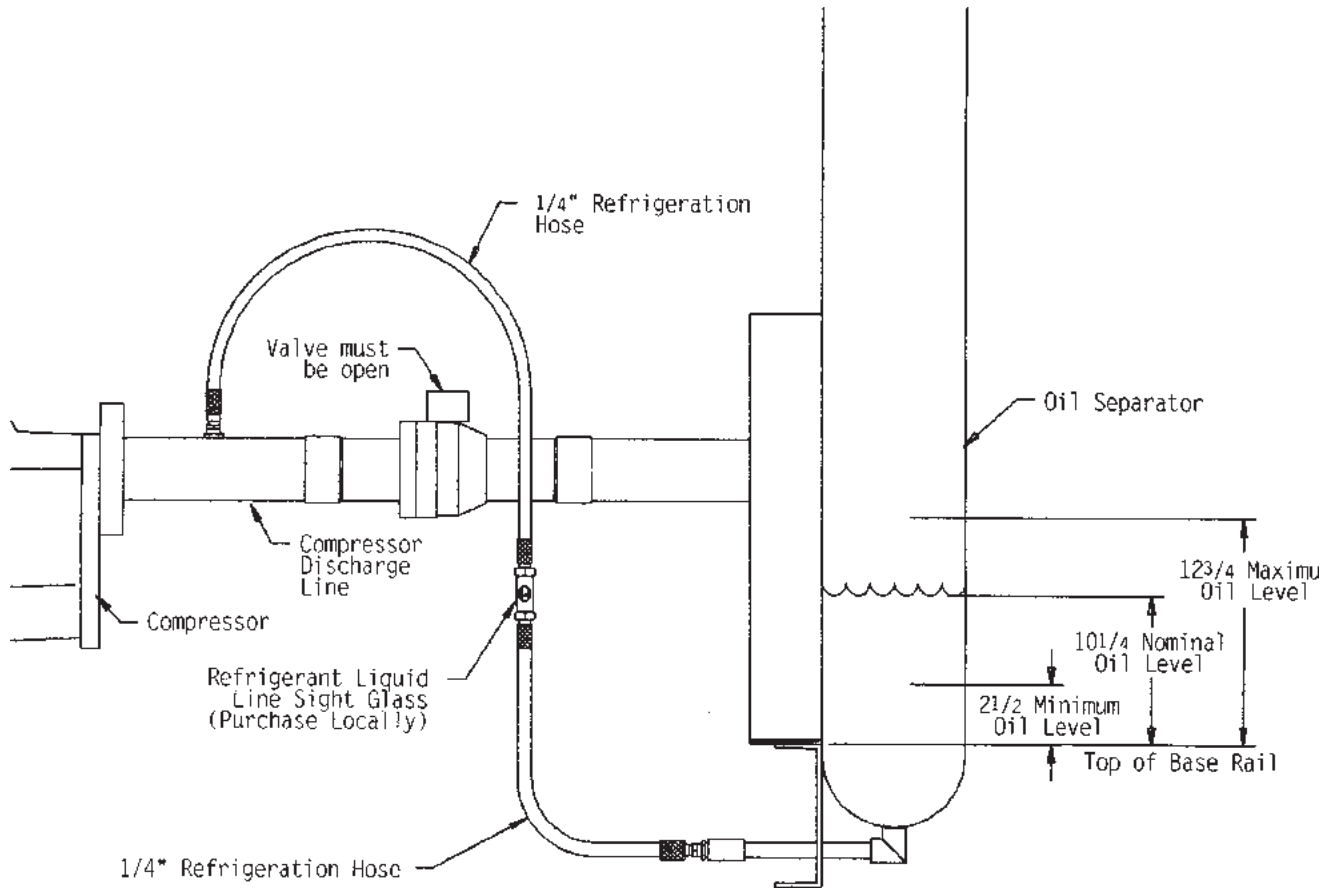

Caution: Do not check oil level with machine operating. Severe oil loss will occur.

Caution: When checking oil level wear protective clothing since oil will spray when discharged.



Condition Codes

UNIT OPERATING STATUS

CODE	DESCRIPTION
Blank	UCM Power Off
888888.8	UCM Paw Up
00	Unit Stop
01	Auto-Local
02	Auto-Remote
17	Service Pumpdown
70	Unit Restart Inhibit
72	Unit Start
74	Run:Normal 1
75	Run :Current Limit
78	Run :Condenser Limit
77	Run:Evaporator Limit
7E	Run:Unload
88	Reset
100	External Unit Stop
101	Ice Building Complete
118	EXV Test
174	Ice Building: Normal
175	Ice Building: Current Limit
176	Ice Building: Condenser Limit
177	Ice Building: Evaporator Limit
200	Low Ambient Run Inhibit

COMPRESSOR OPERATING STATUS

CODE	DESCRIPTION
00	Compressor Stop
16	Compressor Lockout
17	Cprsr Service Pumpdown
70	Cprsr Restart Inhibit
72	Cprsr Start
74	Run Normal
75	Run:Current Limit
76	Run: Condenser Limit
77	Run:Evaporator Limit
7E	Run:Unload

DIAGNOSTIC TYPES

MMR	Machine Shutdown-Manual Reset
CMR	Circuit Shutdown-Man Reset
MAR	Machine Shutdown-Auto Reset
CAR	Circuit Shutdown-Auto Reset
IFW	Informational-Warning

UNIT DIAGNOSTICS CONDITION

FLASHING DISPLAY:

A xxx	
A xxx ↔ C yyy	
b yyy	
C yyy	
10 uu	

MEANS:

A New CMR, CAR, or IFW Diagnostic Exists.
 Operating Code when MMR or MAR occurred. Diagnostic currently inhibiting operation.
 Manual reset required to restore full operation. This or other latching diagnostics exist.
 Condition creating MAR, CAR or IFW still exists. If MMR or CMR, manual reset required.
 The chilled water setpoint is too close to a cutout setpoint.

DASHES:

d ----	
33 ----	
Other (e.g. 14----)	

MEANS:

The chiller is in either Ice bldg or ice bldg compl: lvg chld wtr stpt is not applicable.
 The chiller is in normal cooling; the active ice termination setpoint is not applicable.
 Option either not installed or not enabled.

CODE	DESCRIPTION	TYPE	CODE	DESCRIPTION	TYPE
87	Chock External Chilled Water Stpt	IFW	19F	Phase Loss - Cprsr D	CMR
89	Check External Current Limit Stpt	IFW	1AO	Power Loss - Cprsr A	CAR
8A	Chilled Water Flow (Ent Wtr Temp)	MMR	1A1	Power Loss - Cprsr 8	CAR
8E	Evap Entering Water Temp Sensor	MMR	1A2	Power Loss - Cprsr C	CAR
8F	Cond Rfgt Temp Sensor - Ckt 1	CMR	1A3	Power Loss - Cprsr D	CAR
90	Cond Rfgt Temp Sensor - Ckt 2	CMR	1A4	Remote communications Loss	IFW
93	Evap Rfgt Temp Sensor - Ckt 1	CMR	1A5	Oil Flow Control - Cprsr A	CMR
94	Evap Rfgt Temp Sensor - Ckt 2	CMR	1A6	Oil Flow Control - Cprsr B	CMR
A0	Zone Temp Sensor	IFW	1A7	Oil Flow Control - Cprsr C	CMR
A1	Outdoor Air Temp Sensor	IFW	1A8	Oil Flow Control - Cprsr D	CMR
Ab	Evap Leaving Wtr Temp Sensor	MMR	1A9	EXV Elec Drive Ckt - Rfgt Ckt 1	CMR
bA	Overload Trip - Cprsr A	CMR	1AA	EXV Elec Drive Ckt - Rfgt Ckt 2	CMR
bb	Overload Trip - Cprsr 0	CMR	1Ad	Memory Error Type I (See Oper Manual)	IFW
bC	Overload Trip - Cprsr C	CMR	1AE	Low Differential Press - Ckt 1	CMR
bd	Overload Trip - Cprsr D	CMR	1AF	Low Differential Press - Ckt 2	CMR
bE	High Pressure Cutout - Cprsr C	CMR	1b2	Severe Phase Unbalance - Cprsr A	CMR
bF	High Pressure Cutout - Cprsr D	CMR	1b3	Severe Phase Unbalance - Cprsr B	CMR
C5	Low Chilled Water Temp (U n l t off)	IFW	1b4	Severe Phase Unbalance - Cprsr C	CMR
C6	Low Chilled Water Temp (Unit on)	MAR	1b5	Severs Phase Unbalance - Cprsr 0	CMR
CA	Contactor - Cprsr A	MMR	1b6	Compressor Overload Setting - Cprsr A	IFW
Cb	Contactor - Cprsr B	MMIR	1b7	Compressor Over load Setting - Cprsr B	IFW
cc	Contactor - Cprsr C	MMR	1b8	Compressor Overload Setting - Cprsr C	IFW
Cd	Contactor - Cprsr D	MMR	1b9	Compressor Overload Setting - Cprsr D	IFW
d7	Over Voltage	MAR	1bA	Phase Unbalance - Cprsr A	CMR
d8	Under Voltage	MAR	1bb	Phase Unbalance - Cprsr 8	CMR
Ed	Chilled Water Flow Interlock	MAR	1bC	Phase Unbalance - Cprsr C	CMR
F5	High Pressure Cutout - Cprsr A	CMR	1bd	Phase Unbalance - Cprsr D	CMR
F6	High Pressure Cutout - Cprsr B	CMR	1bE	Winding Temp. - Cprsr A	CMR
Fd	Emergency Stop Input	MMR	1bF	Winding Temp. - Cprsr B	CMR
180	Starter Transition - Cprsr A	CMR	1c0	Winding Temp. - Cprsr C	CMR
181	Starter Transition - Cprsr B	CMR	1C1	Winding Temp. - Cprsr D	CMR
182	Starter Transition - Cprsr C	CMR	1C2	Discharge Temp. - Cprsr A	CMR
183	Starter Transition - Cprsr D	CMR	1C3	Discharge Temp. - Cprsr 8	CMR
184	Phase Reversal - Cprsr A	CMR	1C4	Discharge Temp. - Cprsr C	CMR
185	Phase Reversal - Cprsr 8	CMR	1C5	Discharge Temp. - Cprsr D	CMR
186	Phase Reversal - Cprsr C	CMR	1C6	High Differential Pressure - Ckt 1	CMR
187	Phase Reversal - Cprsr D	CMR	1C7	High Differential Pressure - Ckt 2	CMR
190	Low Superheat - Ckt 1	CMR	1d1	Memory Error Type II (See Oper Manual)	IFW
191	Low Superheat - Ckt 2	CMR	1d2	Memory Error Type III (See Oper Manual)	IFW
194	Low Evap Rfgt Tamp - Ckt 1	CMR	1d3	Cprsr Suction Temp. Sensor - Ckt 1	CMR
195	Low Evap Rfgt Temp - Ckt 2	CMR	1d4	Cprsr Suction Temp. Sensor - Ckt 2	CMR
198	Low Oil 1 Flow - Cprsr A	CMR	1d7	Phase Reversal Prot. Lost - Cprsr A	CMR
199	Low Oil 1 Flow - Cprsr B	CMR	1d8	Phase Reversal Prot. Lost - Cprsr B	CMR
19A	Low Oil Flow - Cprsr C	CMR	1d9	Phase Reversal Prot. Lost - Cprsr C	CMR
19b	Low Oil Flow - Cprsr D	CMR	1dA	Phase Reversal Prot. Lost - Cprsr D	CMR
19C	Phase Loss - Cprsr A	CMR	1db	Slave-Exv Elec Drive Ckt - Rfgt Ckt 1	CMR
19d	Phase Lose - Cprsr B	CMR	1dc	Slave-Exv Elec Drive Ckt - Rfgt Ckt 2	CMR
19E	Phase Loss - Cprsr C	CMR	4xy	See Operator's Manual	---

X3956048201 Rev. B

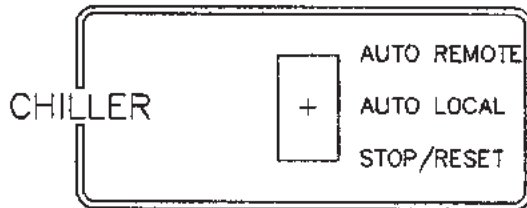
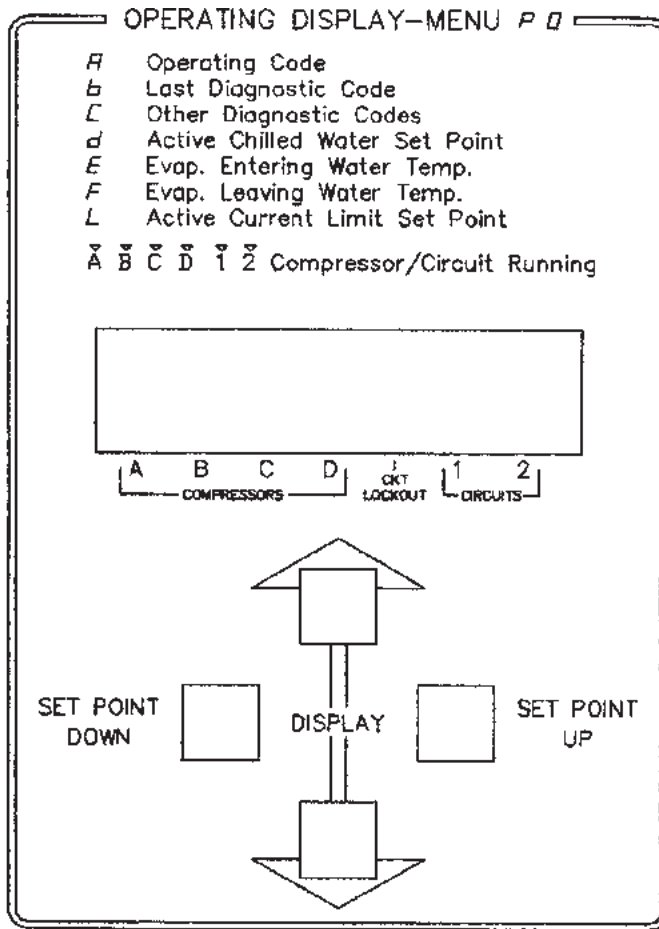

ADAPTIVE CONTROL™

SERVICE DISPLAY—MENU P 1

- 10 Front Panel Chilled Water Set Point
- 11 Design Delta Temp. Set Point
- 12 Differential To Start Set Point
- 13 Front Panel Current Limit Set Point
- 14 Outdoor Air Temp. (Optional)
- 15 Low Ambient Lockout d/E (Opt.)
- 16 Low Amb. Lockout Set Point (Opt.)
- 17 Cond. Entr. Wtr. Temp. (W/C Opt.)
- 18 Cond. Lvg. Wtr. Temp. (W/C Opt.)
- 19 Service Pmpdn d/E (Stop/Reset only)
- 1F Circuit Lockout d/E
- 1b Circuit Diagnostic Reset d/E

SERVICE DISPLAY—MENU P 2

- 20 Compressor Mode
- 21 Compressor Suction Rfgt. Temp.
- 22 Saturated Evaporator Rfgt. Temp.
- 23 Evaporator Refrigerant Pressure
- 24 Saturated Condenser Rfgt. Temp.
- 25 Condenser Refrigerant Pressure
- 26 EXV Test d/E (Stop/Reset only)
- 27 Compressor % RLA
- 28 % Line Volts (Optional)
- 29 Compressor Starts (Optional)
- 2A Compressor Hours (Optional)
- 2b Compressor Test d/E

\bar{A} \bar{B} \bar{C} \bar{D} $\bar{1}$ $\bar{2}$ Flashing Cprsr/Ckt Data

AUXILIARY OPTIONS—MENU P 3

- 30 External Chilled Water Set Point d/E
- 31 External Current Limit Set Point d/E
- 32 Ice Machine Control d/E
- 33 Active Ice Termination Set Point
- 34 Front Panel Ice Termination Set Point
- 35 Return Reset d/E
- 36 Zone Reset d/E
- 37 Outdoor Reset d/E
- 38 Reset Ratio Set Point
- 39 Start Reset Set Point
- 3A Maximum Reset Set Point
- 3b External Circuit Lockout d/E

For further information on this product or other Trane products, refer to the "Trane Service Literature Catalog," ordering number IDX-IOM-1. This catalog contains listings and prices for all service literature sold by Trane. The catalog may be ordered by sending a \$15.00 check to:
 The Trane Company, Service Literature Sales, 3600 Pammel Creek Road, La Crosse, WI 54601.

To help ensure optimum performance, be sure to specify quality Trane parts.

Printed by Production Services - La Crosse